

Field Installation Instructions for End Switch Kit Number 851038

These instructions apply to the field installation of end switch kits on Greenheck’s damper series WD. These end switch kits can be used in conjunction with MP-100, MP-200, and MP-300 series actuators.

End switches are typically wired to a fan and/or to a light serving as an open/not open indicator. When the damper is powered open, one of the damper blades makes contact with the spring rod of the end switch which in turn makes a connection allowing power to flow to the fan and/or light. This set up would be used when it is desirable to ensure that the damper is fully open before the fan starts. For 24 VAC applications, a 115 VAC switch can be used, as long as the 15 amp rating of the switch is not exceeded.

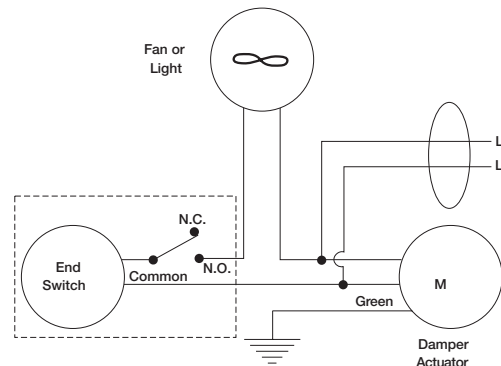

Note: Some actuators are multi-tap, use correct connections per actuator wiring diagram.

Instructions

1. Position end switch such that the back side of damper blade trips the spring rod.
2. Mount end switch bracket to the damper frame or ductwork using #10 x ½ in. self-drilling sheet metal screws.

Part #	Qty.	Description
1	1	End switch mounting bracket
2	1	End switch UL/CSA Rating L67 15 Amps: 125, 250, or 480 VAC 0.25 Amps: 250 VDC 0.50 Amps: 125 VDC
3	2	#6-32NC x 1½ in. machine screws with nuts (packaged in end switch housing)
4	2	#10 x ½ in. self-drilling sheet metal screws

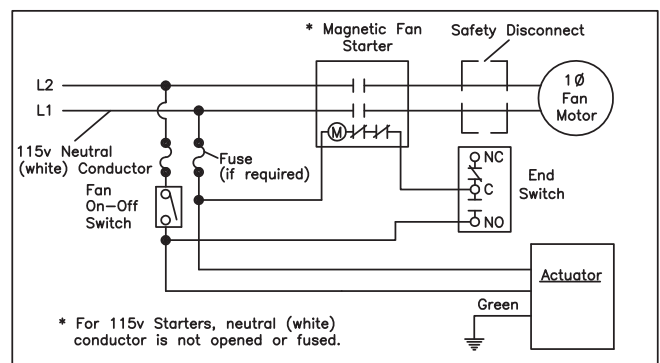

Alternative wiring diagram

End Switch Installation on WD-100 Series Dampers

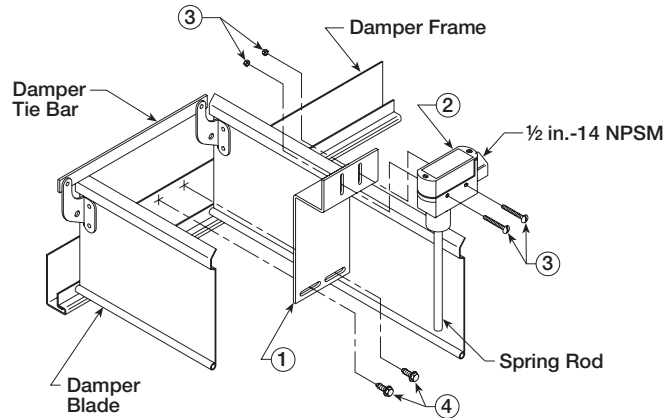

End Switch Installation on WD-200 & 300 Series Dampers

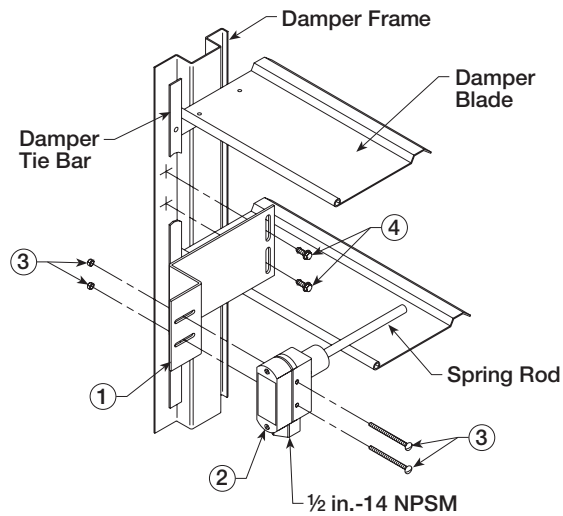

Our Commitment

As a result of our commitment to continuous improvement, Greenheck reserves the right to change specifications without notice.

Specific Greenheck product warranties are located on greenheck.com within the product area tabs and in the Library under Warranties.

