

Installation, Operation and Maintenance Manual

Please read and save these instructions for future reference. Read carefully before attempting to assemble, install, operate or maintain the product described. Protect yourself and others by observing all safety information. Failure to comply with these instructions will result in voiding of the product warranty and may result in personal injury and/or property damage.



Energy Recovery Technical Support
Call 1-800-240-0870



Energy recovery wheels are certified by the AHRI Air-to-Air Energy Recovery Ventilation Equipment Certification Program in accordance with AHRI Standard 1060. Actual performance in packaged equipment may vary.

Certified Ratings are available in the Certified Product Directory at www.ahridirectory.org

General Safety Information

Only qualified personnel should install this system. Personnel should have a clear understanding of these instructions and should be aware of general safety precautions. Improper installation can result in electric shock, possible injury due to coming in contact with moving parts, as well as other potential hazards. Other considerations may be required if high winds or seismic activity are present. If more information is needed, contact a licensed professional engineer before moving forward.

DANGER

Always disconnect power before working on or near this equipment. Lock and tag the disconnect switch or breaker to prevent accidental power up.

CAUTION

When servicing the unit, the internal components may be hot enough to cause pain or injury. Allow time for cooling before servicing.

CAUTION

Precaution should be taken in explosive atmospheres.

1. Follow all local electrical and safety codes, as well as the National Electrical Code (NEC), the National Fire Protection Agency (NFPA), where applicable. Follow the Canadian Electric Code (CEC) in Canada.
2. All moving parts must be free to rotate without striking or rubbing any stationary objects.
3. Unit must be securely and adequately grounded.
4. Do not allow the power cable to kink or come in contact with oil, grease, hot surfaces or chemicals. Replace cord immediately if damaged.
5. Verify that the power source is compatible with the equipment.
6. Never open access doors to the unit while it is running.

Receiving

Upon receiving the product, check to ensure all items are accounted for by referencing the delivery receipt or packing list. Inspect each crate or carton for shipping damage before accepting delivery. Alert the carrier of any damage detected. The customer will make a notation of damage (or shortage of items) on the delivery receipt and all copies of the bill of lading which is countersigned by the delivering carrier. If damaged, immediately contact your Sales Representative. Any physical damage to the unit after acceptance is not the responsibility of manufacturer.

Unpacking

Verify that all required parts and the correct quantity of each item have been received. If any items are missing, report shortages to your local representative to arrange for obtaining missing parts. Sometimes it is not possible that all items for the unit be shipped together due to availability of transportation and truck space. Confirmation of shipment(s) must be limited to only items on the bill of lading.

Handling

Units are to be rigged and moved by the lifting brackets provided or by the skid when a forklift is used. Location of brackets varies by model and size. Handle in such a manner as to keep from scratching or chipping the coating. Damaged finish may reduce ability of unit to resist corrosion.

Storage

Units are protected against damage during shipment. If the unit cannot be installed and operated immediately, precautions need to be taken to prevent deterioration of the unit during storage. The user assumes responsibility of the unit and accessories while in storage. The manufacturer will not be responsible for damage during storage. These suggestions are provided solely as a convenience to the user.

INDOOR — The ideal environment for the storage of units and accessories is indoors, above grade, in a low humidity atmosphere which is sealed to prevent the entry of blowing dust, rain, or snow. Temperatures should be evenly maintained between 30°F (-1°C) and 110°F (43°C) (wide temperature swings may cause condensation and “sweating” of metal parts). All accessories must be stored indoors in a clean, dry atmosphere.

Remove any accumulations of dirt, water, ice, or snow and wipe dry before moving to indoor storage. To avoid “sweating” of metal parts allow cold parts to reach room temperature. To dry parts and packages use a portable electric heater to get rid of any moisture build up. Leave coverings loose to permit air circulation and to allow for periodic inspection.

The unit should be stored at least 3½ in. (89 mm) off the floor on wooden blocks covered with moisture proof paper or polyethylene sheathing. Aisles between parts and along all walls should be provided to permit air circulation and space for inspection.

Inspection and Maintenance during Storage

While in storage, inspect units once per month. Keep a record of inspection and maintenance performed.

If moisture or dirt accumulations are found on parts, the source should be located and eliminated. At each inspection, rotate all moving components by hand ten to fifteen revolutions to distribute lubricant on motor.

Machined parts coated with rust preventive should be restored to good condition promptly if signs of rust occur. Immediately remove the original rust preventive coating with petroleum solvent and clean with lint-free cloths. Polish any remaining rust from surface with crocus cloth or fine emery paper and oil. Do not destroy the continuity of the surfaces. Wipe thoroughly clean with Tectyl® 506 (Ashland Inc.) or the equivalent. For hard to reach internal surfaces or for occasional use, consider using Tectyl® 511M Rust Preventive or WD-40® or the equivalent.

REMOVING FROM STORAGE — As units are removed from storage to be installed in their final location, they should be protected and maintained in a similar fashion, until the equipment goes into operation.

Prior to installing the unit and system components, inspect the unit assembly to make sure it is in working order.

Table of Contents

General Safety Information	1
Receiving, Handling, Storage	2
Mounting	2
Electrical Connections	3
Start-Up	4
Drive Belt	4
Air Seals	4
Dimensional Data & Specifications	5
Installation Clearances	5
Routine Maintenance	
Energy Recovery Wheel	6
Energy Recovery Wheel Maintenance	6
Energy Recovery Wheel Access	6
Removal of Segments	6
Cleaning the Energy Recovery Wheel	6
Energy Recovery Wheel Belt	6
Energy Recovery Wheel Bearings	6
Parts List	7
Troubleshooting	7
Maintenance Log	Backcover
Our Commitment	Backcover

Electrical Connections

The electrical supply must be compatible with that shown on the wheel drive motor nameplate: voltage, phase, and amperage capacity. Units are supplied with a receptacle for the cassette plug and service box for wiring. Connect the ERM wiring directly to blower wiring or to blower fan relay to power the ERM whenever the fan is in operation. All wiring must be properly fused and conform to local and national electrical codes.

Do not operate the ERM for any extended period without airflow across the energy wheel as the drive motor is cooled by the airflow.

Mounting

NOTE
ERM must be installed such that an energy wheel cassette slides in and out of the cabinet parallel to the floor.
NOTE
To reduce unit weight for handling purposes, the cassette may be removed from the cabinet.
NOTE
Adjusting the diameter seals on the front and back of wheel prior to mounting is recommended as access will be limited once in place. See Start-Up, Air Seals for adjustment procedures.

The ERM is designed for indoor mounting only and is shipped with a mounting kit containing hanging brackets. These brackets will support the ERM in either the vertical or horizontal position for design flexibility.

To hang the ERM:

1. If cassette removal is desired, remove the access panel and unplug the wheel drive motor at the electrical receptacle in the cabinet, then slide wheel out.
2. Replace the access panel before mounting to ensure squareness.
3. Use the brackets as shown in Figure 1 to secure the ERM. These brackets are designed for 3/8 in. threaded hanging rods.
4. To reinstall the cassette in the mounted ERM cabinet, align the cassette sliders with the channels in the cabinet and slide the cassette in place. Replace access panel when finished.

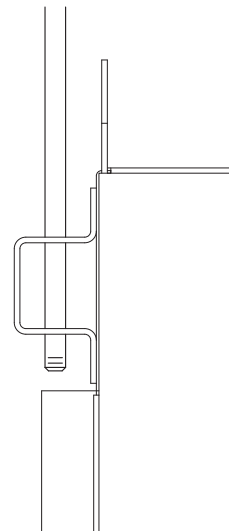

Figure 1

Start-Up

DANGER

Electric shock hazard. Can cause injury or death. Before attempting to perform any service or maintenance, turn the electrical power to unit to OFF.

CAUTION

Use caution when removing access panels or other unit components, especially while standing on a ladder or other potentially unsteady base. Access panels and unit components can be heavy and serious injury may occur.

Every installation requires a comprehensive start-up to ensure proper operation of the unit. As part of that process, the following information must be recorded. Should an issue arise which requires factory assistance, this important information will allow unit experts to provide quicker resolve. Qualified personnel should perform start-up to ensure safe and proper practices are followed.

Unit Model Number	_____
	(e.g. ERM-36H-15)
Unit Serial Number	_____
	(e.g. 04C99999 or 10111000)
Energy Wheel Date Code	_____
	(e.g. 0450)
Start-up date	_____
	(MM/DD/YYYY)
Start-up Personnel Name	_____
Start-up Company	_____
Phone Number	_____

The ERM models contain a total energy recovery wheel. The wheels are inspected for proper mechanical operation at the factory. However, during shipping and handling, shifting can occur that may affect wheel operation. The wheel is accessible through the cassette access panel.

Turn the energy recovery wheel by hand to verify free operation. The wheel should rotate smoothly at approximately 50-60 rpm and should not wobble. If the wheel does not rotate when power is applied, it may be necessary to adjust excessively tight diameter air seals.

WARNING

Do not operate Energy Recovery Module without duct filters or screens installed. The filters and screens prevent the entry of foreign objects such as leaves, birds, etc.

Drive Belt

Inspect the drive belt. Make sure the belt rides smoothly through the pulley and over the rim.

Air Seals

Check that the air seals located around the outside of the wheel and across the center (both sides of wheel) are secure and in good condition. Air seal clearance is determined by placing a sheet of paper, to act as a feeler gauge, against the wheel face. To access seals, remove cassette access panel. To adjust their seals, loosen all eight seal retaining screws. These screws are located on the bearing support that spans the length of the cassette through the wheel center. Tighten the screws so the air seals tug slightly on the sheet of paper.

Replace cassette into ERM cabinet, plug in wheel drive, replace access door and apply power. Confirm that the wheel rotates freely at about 50-60 rpm.

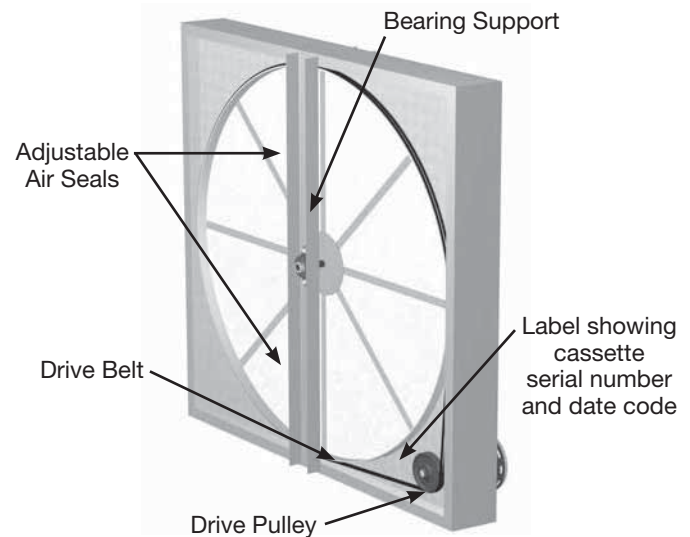

Dimensional Data and Specifications

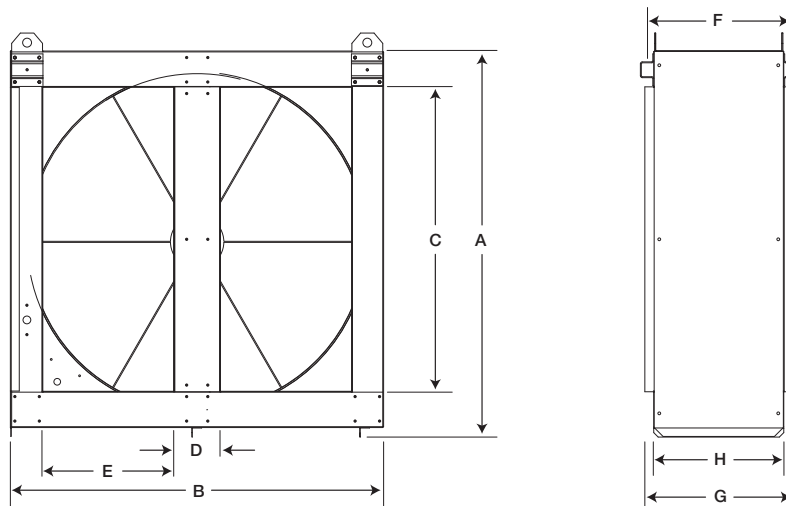

Model	A	B	C	D	E	F	G	H	Voltage	Hertz	Phase	Amps	Motor HP	Weight (lbs.)	
														Cabinet	Cassette
ERM-36S-15	44½	42	34¼	5	14¾	16⅝	16⅝	14⅝	200-230/460	50/60	1	0.6	1/20	95	80
ERM-36H-15	44½	42	34¼	5	14¾	16⅝	16⅝	14⅝	200-230/460	50/60	1	0.6	1/20	95	80
ERM-36H-30	44½	42	34¼	5	14¾	16⅝	16⅝	14⅝	200-230/460	50/60	1	0.6	1/20	95	118
ERM-52S-15	60¾	58¼	50½	6½	17¾	16⅝	16⅝	14⅝	200-230/460	50/60	1	1.2	1/6	135	188
ERM-52H-15	60¾	58¼	50½	6½	17¾	16⅝	16⅝	14⅝	200-230/460	50/60	1	1.2	1/6	135	188
ERM-52H-30	60¾	58¼	50½	6½	17¾	16⅝	16⅝	14⅝	200-230/460	50/60	1	1.2	1/6	135	220

All dimensions shown are in inches.

Installation Clearances

Provide proper clearance for cassette inspection, service or removal. Do not install ducting, piping or wiring where it will interfere with cassette removal.

Model	Inspection or Service	Removal
ERM-36	22	42
ERM-52	30	58

All dimensions shown are in inches.

Routine Maintenance

Once the unit has been put into operation, a routine maintenance program should be set up to preserve reliability and performance. Items to be included in this program are:

Energy Recovery Wheel

- Check for cleanliness - clean if required
- Check belt for wear
- Check pulley, bearings, and motor

Energy Recovery Wheel Maintenance

Annual inspection of the energy recovery wheel is recommended. Units ventilating smoking lounges and other non-clean air spaces should have energy recovery wheel inspections more often based upon need. Inspections for smoke ventilation applications are recommended bimonthly to quarterly until a regular schedule can be established.

Accessing the Energy Recovery Wheel

Disconnect power to the ERM unit. Access to the wheel must be obtained through ductwork access point.

Removing the Energy Recovery Wheel Segments

Rotate the wheel by hand clockwise (as viewed from the pulley side of cassette) to check each segment. Steel retainers are located on the inside of the wheel rim (see diagram). Push the retainer toward center of wheel, then lift up and away to release segments.

Reverse the above instructions to reinstall the energy recovery wheel segments.

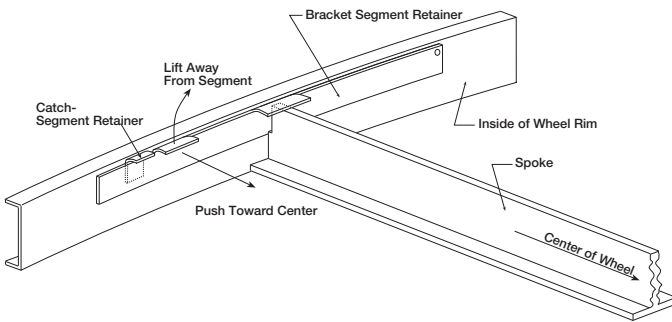

IMPORTANT

Place retainers back in the original position before rotating the energy recovery wheel. Otherwise, damage to the retainer will occur.

Cleaning the Energy Recovery Wheel

If the wheel appears excessively dirty, it should be cleaned to ensure maximum operating efficiency. Only excessive buildup of foreign material needs to be removed. Discoloration and staining of energy recovery wheel does not affect its performance.

Thoroughly spray wheel matrix with household cleaner such as Fantastik® or equivalent. Gently rinse with warm water and using a soft brush remove any heavier accumulation. A detergent/water solution can also be used. The energy recovery wheel segments can be soaked in this solution overnight for stubborn dirt or accumulation. Do NOT use aggressive solvents such as acetone.

After cleaning is complete, shake the excess water from the wheel or segments. Dry wheel or segments before placing them back into the cassette. Place wheel or segments back into cassette by reversing removal procedures.

CAUTION

Do not clean energy recovery wheel segments with water in excess of 140°F (60°C).

Do not dry energy recovery wheel segments in air in excess of 140°F (60°C).

Do not use a pressure washer to clean segments as damage could result.

Energy Recovery Wheel Belt

Inspect belts each time filters are replaced. Belts that look chewed up or are leaving belt dust near the motor pulley may indicate a problem with the wheel. Be sure to inspect wheel for smooth and unrestricted rotation. If a belt requires replacement, contact the local Greenheck representative. Instructions for replacement will ship with the new belt.

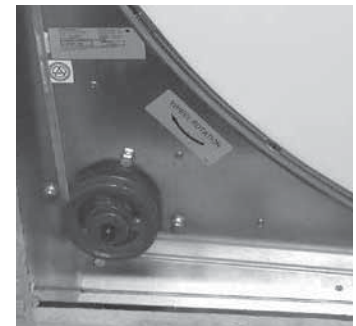

Wheel Belt & Pulley

Energy Recovery Wheel Bearing

In the unlikely event that a wheel bearing fails, the bearing is behind a removable plate on the wheel support beam. Contact the local Greenheck representative for detailed instructions on how to replace the bearing.



Wheel Bearing

Parts List

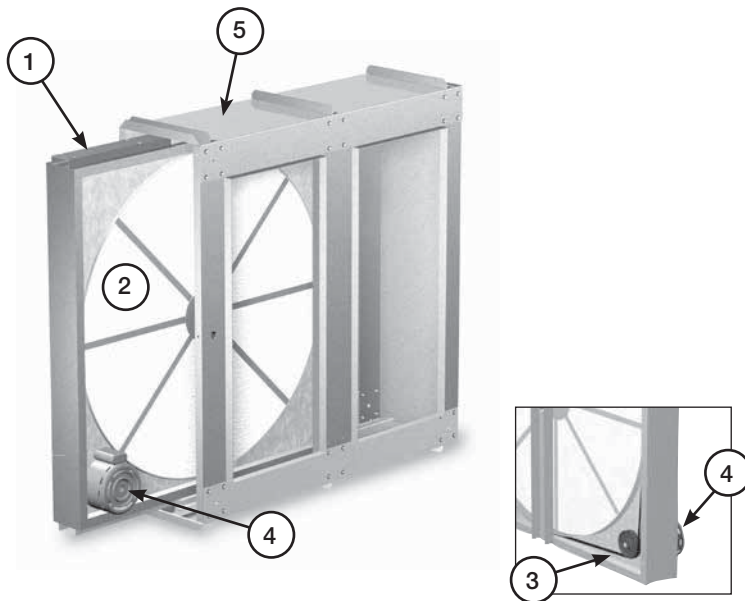

1. Cassette
2. Energy Wheel Segments
3. Energy Wheel Drive Belt and Pulley
4. Energy Wheel Motor
5. Cabinet

The ERM mounting brackets are factory installed.

Troubleshooting

Symptom	Possible Cause	Corrective Action
Energy Wheel does NOT turn	Air seals are too tight.	See air seals under Start-Up section.
	Broken belt.	Replace.
	No power to wheel motor.	Make sure wheel drive is plugged in. Verify power is available.
Energy Wheel runs intermittently	Wheel motor overloads are tripping due to rubbing between wheel and air seals.	Recheck air seals, make sure they are not too tight. See Air Seals under Start-Up section.

Maintenance Log

Date _____ Time _____ AM/PM

Notes: _____

Date _____ Time _____ AM/PM

Notes: _____

Date _____ Time _____ AM/PM

Notes: _____

Date _____ Time _____ AM/PM

Notes: _____

Date _____ Time _____ AM/PM

Notes: _____

Date _____ Time _____ AM/PM

Notes: _____

Date _____ Time _____ AM/PM

Notes: _____

Date _____ Time _____ AM/PM

Notes: _____

Our Commitment

As a result of our commitment to continuous improvement, Greenheck reserves the right to change specifications without notice.

Product warranties can be found online at Greenheck.com, either on the specific product page or in the literature section of the website at Greenheck.com/Resources/Library/Literature.

Greenheck's Energy Recovery Ventilators, Models MiniVent, ERV, ERVe and ERM catalog provides additional information describing the equipment, fan performance, available accessories, and specification data.

AMCA Publication 410-96, Safety Practices for Users and Installers of Industrial and Commercial Fans, provides additional safety information. This publication can be obtained from AMCA International, Inc. at www.amca.org.

