

Installation, Operation and Maintenance Manual

Please read and save these instructions for future reference. Read carefully before attempting to assemble, install, operate or maintain the product described. Protect yourself and others by observing all safety information. Failure to comply with these instructions will result in voiding of the product warranty and may result in personal injury and/or property damage.

Energy Recovery Technical Support
Call 1-800-240-0870

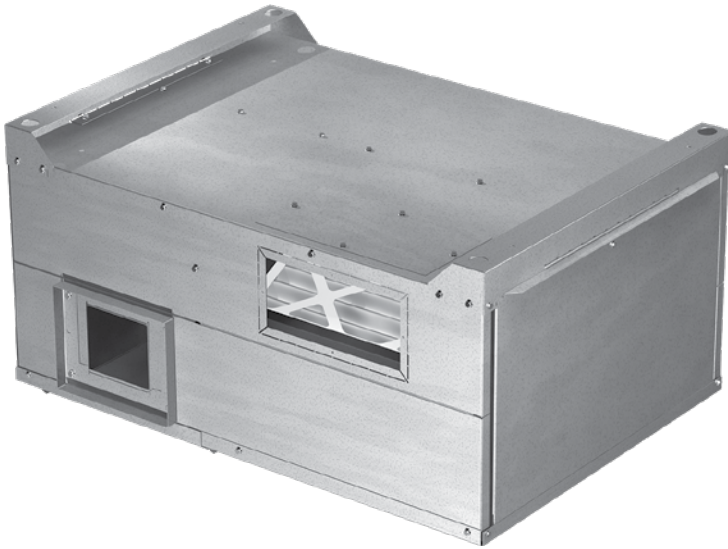

General Safety Information

Only qualified personnel should install this system. Personnel should have a clear understanding of these instructions and should be aware of general safety precautions. Improper installation can result in electric shock, possible injury due to coming in contact with moving parts, as well as other potential hazards. Other considerations may be required if high winds or seismic activity are present. If more information is needed, contact a licensed professional engineer before moving forward.

DANGER

Always disconnect power before working on or near this equipment. Lock and tag the disconnect switch or breaker to prevent accidental power up.

CAUTION

When servicing the unit, the internal components may be hot enough to cause pain or injury. Allow time for cooling before servicing.

CAUTION

Precaution should be taken in explosive atmospheres.

1. Follow all local electrical and safety codes, as well as the National Electrical Code (NEC), the National Fire Protection Agency (NFPA), where applicable. Follow the Canadian Electrical Code (CEC) in Canada.
2. All moving parts must be free to rotate without striking or rubbing any stationary objects.
3. Unit must be securely and adequately grounded.
4. Do not spin fan wheel faster than maximum cataloged fan RPM. Adjustments to fan speed significantly affects motor load. If the fan RPM is changed, the motor current should be checked to make sure it is not exceeding the motor nameplate amps.
5. Do not allow the power cable to kink or come in contact with oil, grease, hot surfaces or chemicals. Replace cord immediately if damaged.
6. Verify that the power source is compatible with the equipment.
7. Never open access doors to the unit while it is running.

Table of Contents

General Safety Information	1
Unit Overview	2
Receiving, Handling, Storage	3
Dimensional Data and Weights	4
Service Clearances and Access Panel Locations.	4
Intake and Discharge Locations	5
Installation	6
Electrical Connections	8
Wiring Schematics	9
System Start-Up	10
Routine Maintenance	13
Standard Components	14
Troubleshooting.	15
Maintenance Log.	Backcover
Our Commitment.	Backcover

Unit Overview

Summer Operation

Outdoor air is preconditioned (temperature and moisture levels are decreased) by the transfer of energy from the cooler, drier return air through the energy recovery core. The preconditioned air is typically mixed with return air going back to the air handler for final conditioning.

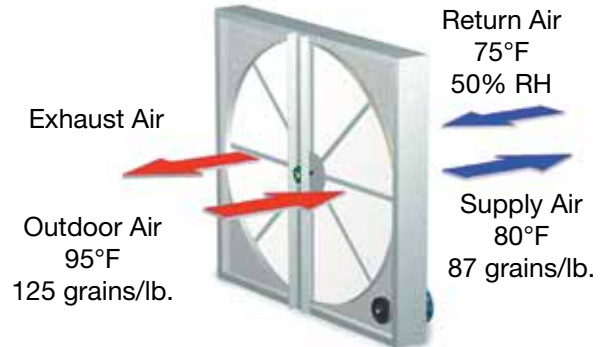

Summer Operation

Winter Operation

Outdoor air is preconditioned (temperature and moisture levels are increased) by the transfer of energy from the warmer, more humid return air through the energy recovery core. The preconditioned air is typically mixed with return air going back to the air handler for final conditioning.

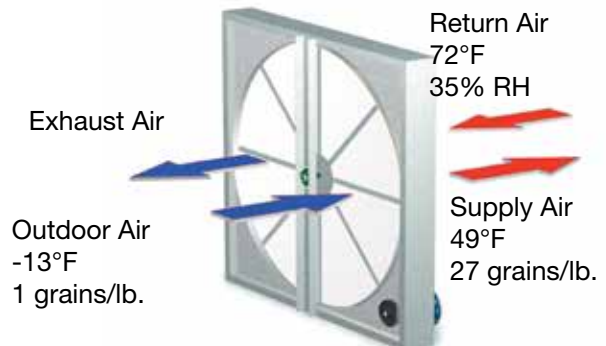

Winter Operation

Receiving

This product may have been subject to road salt during transit. If so, immediately wash off all visible white residue from all exterior surfaces. Upon receiving the product, check to ensure all items are accounted for by referencing the delivery receipt or packing list. Inspect each crate or carton for shipping damage before accepting delivery. Alert the carrier if any damage is detected, **do not refuse shipment**. The customer shall make notation of damage (or shortage of items) on the delivery receipt and all copies of the bill of lading should be countersigned by the delivering carrier. If damaged, immediately contact your manufacturer's representative. Any physical damage to the unit after acceptance is not the responsibility of the manufacturer.

Handling

Units are to be rigged and moved by the lifting brackets provided or by the skid when a forklift is used. Location of brackets varies by model and size. Handle in such a manner as to keep from scratching or chipping the coating. Damaged finish may reduce ability of unit to resist corrosion.

Unpacking

Verify that all required parts and the correct quantity of each item have been received. Inspect interior of unit cabinet for any shipped loose items. If any items are missing, report shortages to your local representative to arrange for obtaining missing parts. Sometimes it is not possible that all items for the unit be shipped together due to availability of transportation and truck space. Confirmation of shipment(s) must be limited to only items on the bill of lading.

Storage

Units are protected against damage during shipment. If the unit cannot be installed and operated immediately, precautions need to be taken to prevent deterioration of the unit during storage. The user assumes responsibility of the unit and accessories while in storage. The manufacturer will not be responsible for damage during storage. These suggestions are provided solely as a convenience to the user.

The ideal environment for the storage of units and accessories is indoors, above grade, in a low humidity atmosphere which is sealed to prevent the entry of blowing dust, rain, or snow. Units designed for outdoor applications may be stored outdoors. All accessories must be stored indoors in a clean, dry atmosphere.

Indoor

Maintain temperatures evenly to prevent condensation. Remove any accumulations of dirt, water, ice, or snow and wipe dry before moving to indoor storage. To avoid condensation, allow cold parts to reach room temperature. Leave coverings loose to permit air circulation and to allow for periodic inspection.

The unit should be stored at least 3½ in. (89 mm) off the floor. Clearance should be provided to permit air circulation and space for inspection.

Outdoor

The unit should be placed on a level surface to prevent water from leaking into the unit. The unit should be elevated so that it is above water and snow levels. Ensure sufficient support to prevent unit from settling into soft ground. Locate parts far enough apart to permit air circulation, sunlight, and space for periodic inspection. To minimize water accumulation, place all unit parts on blocking supports so that rain water will run off.

Do not cover parts with plastic film or tarps as these cause condensation of moisture from the air passing through heating and cooling cycles.

Inspection and Maintenance

While in storage, inspect units once per month. Keep a record of inspection and maintenance performed.

If moisture or dirt accumulations are found on parts, the source should be located and eliminated. At each inspection, rotate the fan wheel by hand ten to fifteen revolutions to distribute lubricant on motor. If paint deterioration begins, consideration should be given to touch-up or repainting. Units with special coatings may require special techniques for touch-up or repair.

Machined parts coated with rust preventive should be restored to good condition promptly if signs of rust occur. Immediately remove the original rust preventive coating with petroleum solvent and clean with lint-free cloths. Polish any remaining rust from surface with crocus cloth or fine emery paper and oil. Do not destroy the continuity of the surfaces. Wipe thoroughly clean with Tectyl® 506 (Ashland Inc.) or the equivalent. For hard to reach internal surfaces or for occasional use, consider using Tectyl® 511M Rust Preventive, WD-40® or the equivalent.

Removing from Storage

As units are removed from storage to be installed in their final location, they should be protected and maintained in a similar fashion until the equipment goes into operation.

Prior to installing the unit and system components, inspect the unit assembly to make sure it is in working order.

1. Check all fasteners, set screws on the fan, wheel, bearings, drive, motor base, and accessories for tightness.
2. Rotate the fan wheel(s) by hand and assure no parts are rubbing.

Dimensional Data and Weights

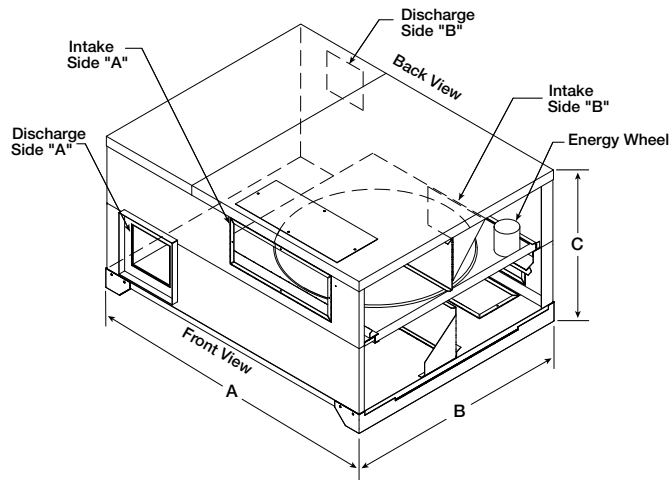

MiniVent	A	B	C	Weight (lbs.)
450	40.2	28.6	19.9	160
750	45.8	35.3	23.8	240

All dimensions are in inches.

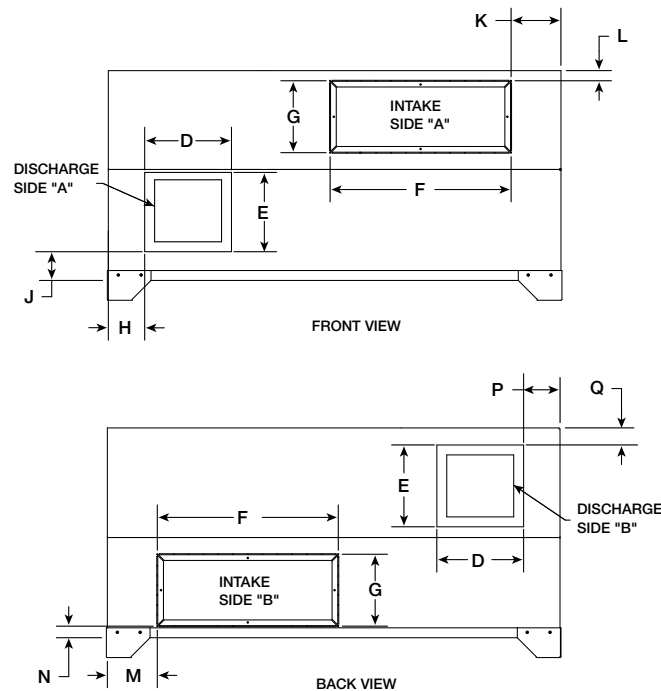

MiniVent	D	E	F	G	H	J	K	L	M	N	P	Q
450	10	8	12	6	4.3	1.4	6	1.5	6	1	4.8	3.4
750	10	10	18	7	4	2.2	5.1	1.5	5.1	1.1	4	1.5

All dimensions are in inches.

Intake and Discharge positions are not labeled because they are configurable by rotation of the unit about the vertical axis. The supply and exhaust can be on either side, but the intake/exhaust relationship must be maintained. For example, Outdoor Air Intake = Intake Side "B"/Outdoor Air Discharge = Discharge Side "B". The preferred configuration is to have the energy wheel motor in the exhaust airstream.

Service Clearances and Access Panel Locations

Recommended Service Clearances

The MiniVent requires minimum clearances to perform routine maintenance, such as filter replacement, energy wheel cassette and fan inspection. Fan and motor assemblies, energy recovery wheel cassette and filter sections are provided with a service door or panel for proper component access.

MiniVent	A	B
450	25	15
750	31	21

All dimensions are in inches.

Access Panel Locations

- Outdoor and exhaust fans and motor
• Electrical connection
- Energy wheel cassette
• Internal filters

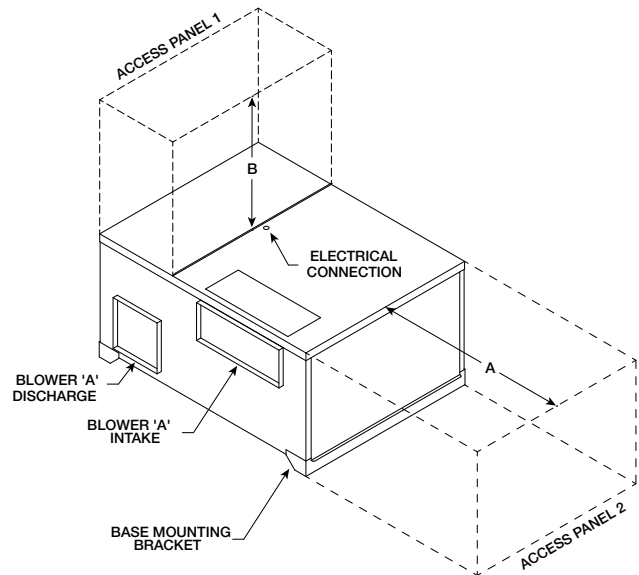

BASE MOUNTED

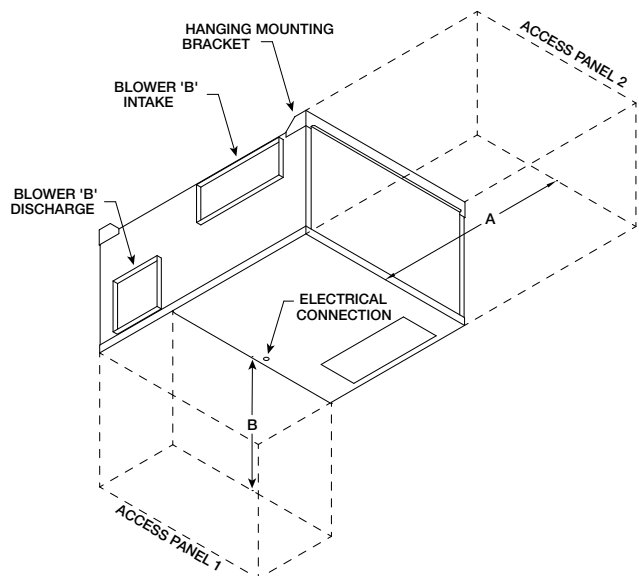

HANG MOUNTED

Intake and Discharge Locations

Intake and discharge locations are shown. Both intake locations are capable of being field relocated to suit installation needs (see optional locations).

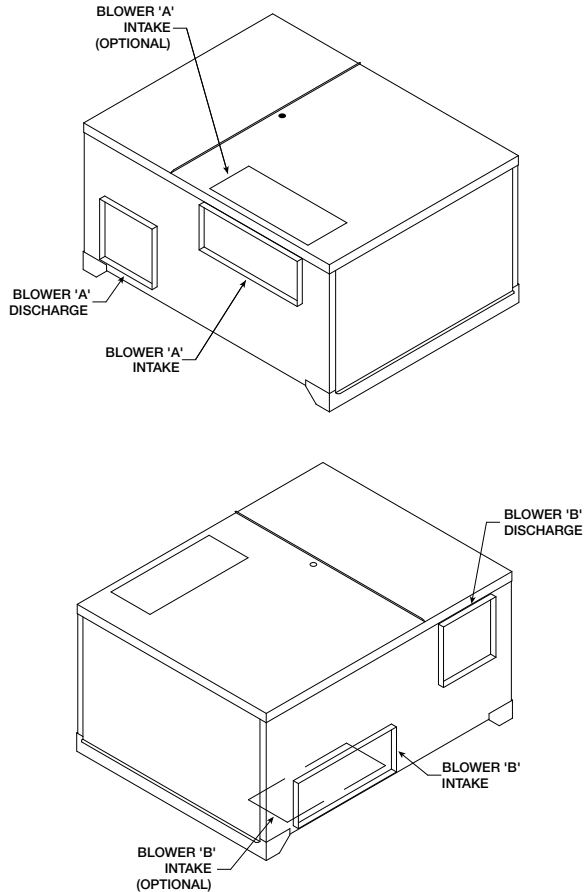

Changing the Discharge Location

Step 1 - Disconnect and lockout all power switches.

Step 2 - Remove the sheet metal block off from the desired discharge location.

Step 3 - Cut the insulation from the desired discharge location opening.

Step 4 - Remove the backdraft damper from its current position and reinstall in the desired discharge location. The hinged door should be on the discharge end of the unit.

Step 5 - Glue the cut out insulation to the sheet metal block off. Install where the damper had been located.

Step 6 - Remove the four (4) 5/16 inch sheet metal screws from the discharge end of the unit that holds the blowers.

Step 7 - Remove the four (4) plastic plugs from the desired discharge location and reinstall the plastic plugs in the holes where the bolts were removed from in Step 6.

Step 8 - Position the blowers to line up with the desired discharge location. The motor needs to be on the discharge end of the blower and unit. If the motor is positioned on the return side of the blower/unit, the

motor/blower will interfere with the energy recovery wheel. The blower adjacent to the control center needs to be rotated 90°. The blower not adjacent to the control center needs to be flipped and rotated such that the motor is now opposite the control center side of the unit. It may be necessary to unwire the motors.

Step 9 - Secure the blowers in their desired locations, reconnect and fasten all wires.

Changing the Inlet Location

Step 1 - Remove the metal cover for optional inlet location by unfastening the four (4) sheet metal screws holding it in place.

Step 2 - Hand bend flanges out to form a duct collar in the newly uncovered intake opening.

Step 3 - Cut insulation.

Step 4 - Hand bend flanges in on original intake and replace metal cover removed in Step 1.

Installation

The system design and installation should follow accepted industry practice, such as described in the ASHRAE Handbook and SMACNA.

Minimum service clearance should be provided on the side of the unit for routine service and component removal should it become necessary.

Before beginning installation see page 3 for detail on appropriate service clearances.

Hang Mounting with Hanging Vibration Isolators

- The hanging isolator kit includes four (4) isolators and required hardware.
- Locate the support rods as shown in the drawing.
- Assemble each isolator as shown.

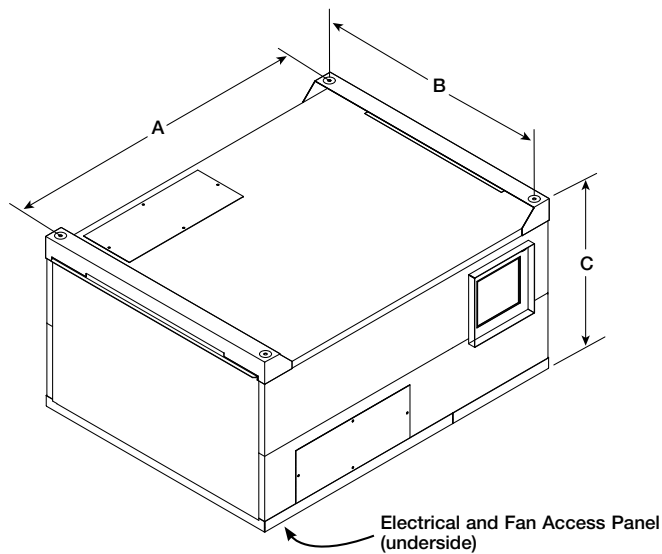

MiniVent	A	B	C
450	37.6	26.4	19.9
750	43.2	33	23.8

All dimensions are in inches.

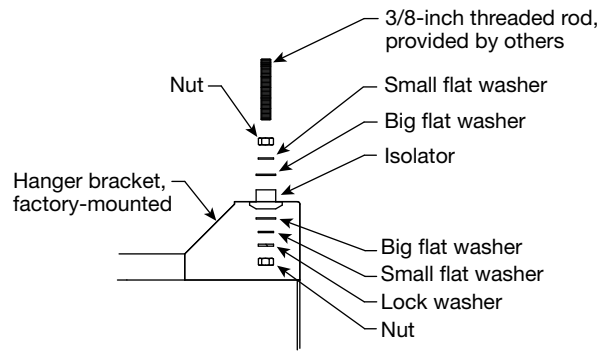

**Hanging Vibration Isolator Assembly
MiniVent-450**

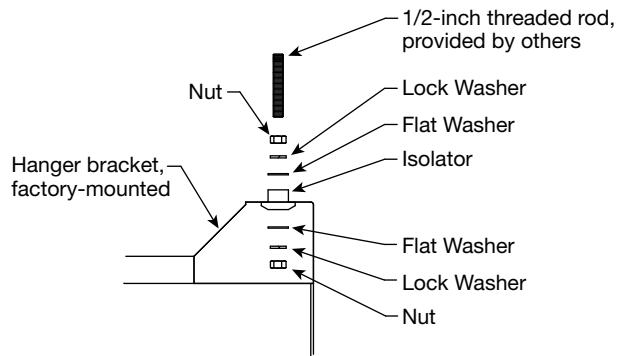

**Hanging Vibration Isolator Assembly
MiniVent-750**

Base Mounting with Base Vibration Isolation

- The base isolators kit includes four (4) isolators, four (4) brackets and required hardware.
- Rotate the MiniVent 180 degrees, so the electrical and fan component panel is accessible from the top. The corners, where the brackets are fastened, are now closest to the mounting surface.
- Assemble and mount the isolators as shown in the figures below.

Note: The hanging and base mounting brackets are fastened to the same unit corners.

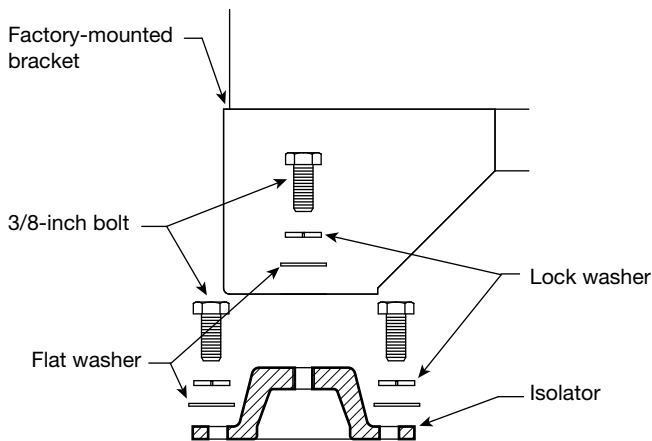
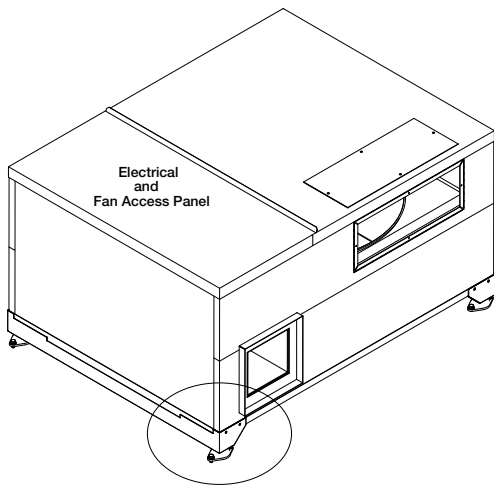

Base Vibration Isolator Assembly

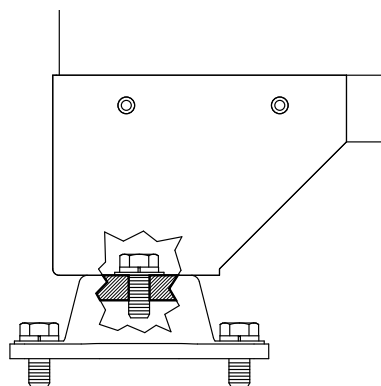

Assembled and Mounted Isolator Detail

Ductwork Connections

Examples of poor and good fan-to-duct connections are shown. Airflow out of the fan should be directed straight or curve the same direction as the fan wheel rotates. Poor duct installation will result in low airflow and other system effects.

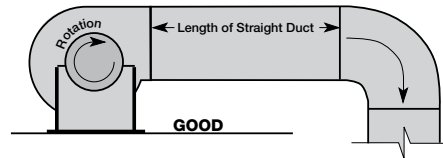
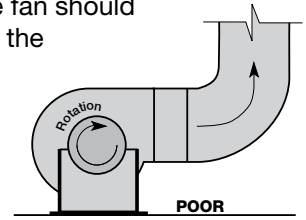

Recommended Discharge Duct Size and Length

MiniVent	Blower Size	Duct Size (in.)	Straight Duct Length (ft.)
450	8	10 x 8	3
750	10	10 x 10	3

- Recommended duct sizes are based on velocities across the cfm range of each model at approximately 800 feet per minute (FPM) at minimum airflow and up to 1600 fpm at maximum airflow. Recommended duct sizes are only intended to be a guide and may not satisfy the requirements of the project. Refer to plans for appropriate job specific duct size and/or velocity limitations.
- Straight duct lengths were calculated based on 100% effective duct length requirements as prescribed in AMCA Publication 201. Calculated values have been rounded up to nearest foot.

Electrical Connections

Before connecting power to the unit, read and understand the following instructions and wiring diagrams. Complete wiring diagrams are attached inside the blower door of the unit.

All wiring should be done in accordance with the National Electrical Code ANSI/NFPA 70 latest edition and any local codes that may apply. In Canada, wiring should be done in accordance with the Canadian Electrical Code. The equipment must be properly grounded.

Caution

If any of the original wire must be replaced, the replacement wire must have a temperature rating of at least 105°C.

DANGER

High voltage electrical input is required for this equipment. This work should be performed by a qualified electrician.

Electrical Connection Location

MiniVent	A	B
450	21.875	12.5
750	28.375	15.5

All dimensions are in inches.

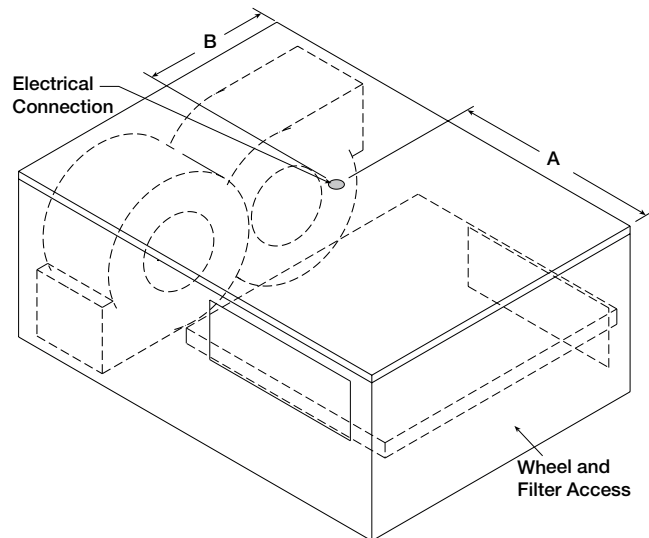

Sequence for Wiring Unit

1. The unit's nameplate contains the voltage and total amperage required. The wire supplying power to the unit should be sized accordingly.
2. The main power line should be connected to the appropriate terminal blocks.
Power may be routed to the unit through the opening on the underside of the unit. The locations for the opening are provided in the figure to the right.
3. Refer to the wiring diagrams in this manual or in the unit for controlling the unit.

Frost Control

Extremely cold outdoor air temperatures can cause moisture condensation and frosting on the energy recovery wheel. Frost control is an optional feature that will prevent/control wheel frosting.

1. Timed exhaust frost control

This option is provided with a thermodisc mounted in the outdoor air intake compartment.

Timed exhaust frost control includes a timer in addition to the thermodisc. When timed exhaust frost control is initiated, the timer will turn the supply blower off. Time exhaust using default timer setting will shut down the supply fan for 5 minutes every 30 minutes to allow exhaust to defrost energy wheel. Use the test procedure for troubleshooting.

Frost Control Test Procedure

1. Remove power from unit.
2. Jumper the temperature indicating thermodisc in the unit control center. Thermodisc has a pre-set temperature of 5°F.
3. Set the frost control timer scale for T1 and T2 to 1m. Set the timer settings for T1 and T2 to 10.
4. Add power to the unit. Blower should cycle on for one minute, then turn off for one minute.
5. Remove power from unit and remove jumpers that were placed. Re-set timer settings.
 - **T1** timer setting set to **5** and timer scale set to **10m** for 5 minutes of wheel off time.
 - **T2** timer setting set to **5** and timer scale set to **1h** for 30 minutes of wheel on time

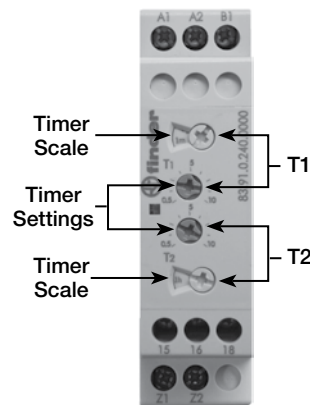

Wiring Schematics

Timed Exhaust Frost Control

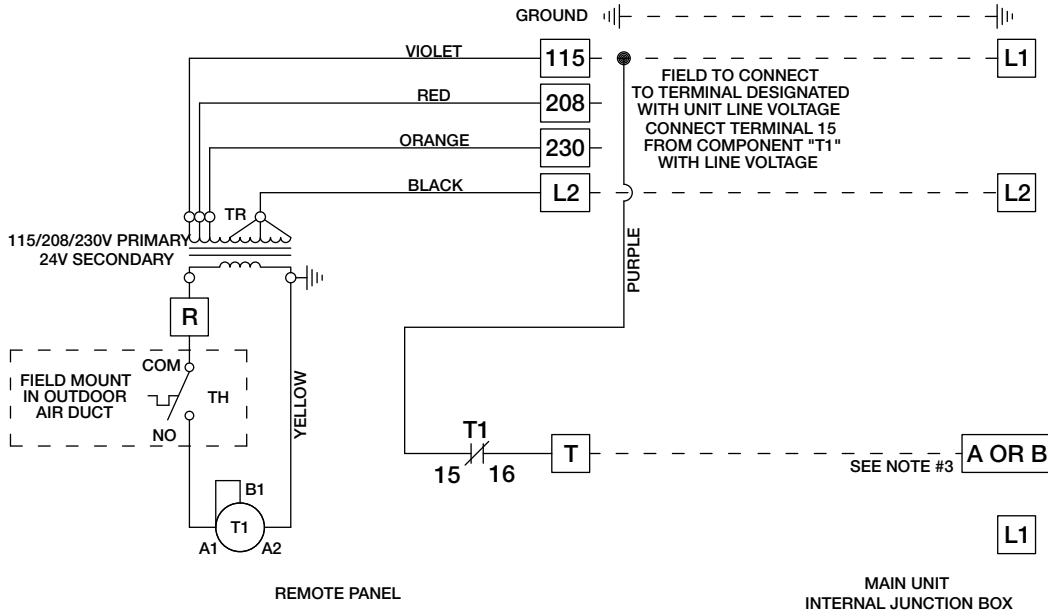

Motor Potentiometer/0-10 VDC Fan Motor Control

(VERIFY MAIN UNIT POWER ON UNIT NAMEPLATE)
MAIN UNIT POWER -110/50/1-115/60/1

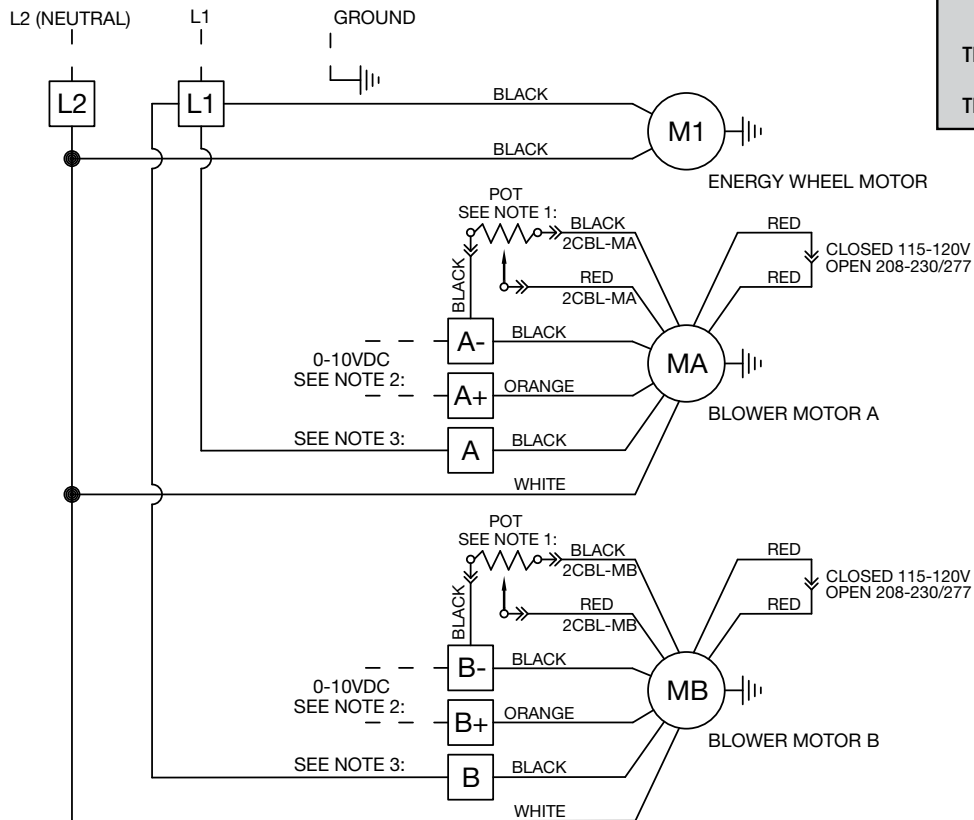

Legend

- M1 Energy Wheel Motor
- MA Blower Motor A
- MB Blower Motor B
- POT Potentiometer (located in control center)
- T1 Frost Control Timer
Typical Settings: t1 (OFF) = 5 min.
t2 (ON) = 30 min.
- TH Thermostat; non-adjustable 5° setting.
Required to be mounted in outdoor air duct.
- TR Transformer

NOTE 1: Potentiometer is mounted in control center. Turn dial for speed adjustments to motor.

NOTE 2: 0-10 VDC fan motor control by others. For 0-10 input, potentiometer must be set to 0.
0-1.9 VDC fan motors are off
2 VDC - minimum speed
ON threshold
(from previous off) - 2 VDC
OFF threshold
(from previous on) - 1.5 VDC
10 VDC - maximum speed

If one 0-10 VDC signal is present for both motors, place a jumper between the following terminals. (A+ and B+) and (A- and B-)

NOTE 3: If frost control panel accessory is installed, determine if Blower Motor A or B controls the supply fan and remove jumper wire between L1 and supply motor.

System Start-Up

DANGER

Electric shock hazard. Can cause injury or death. Before attempting to perform any service or maintenance, turn the electrical power to unit to OFF at disconnect switch(es). Unit may have multiple power supplies.

CAUTION

Use caution when removing access panels or other unit components, especially while standing on a ladder or other potentially unsteady base. Access panels and unit components can be heavy and serious injury may occur.

CAUTION

Do not operate without the filters and birdscreens installed. They prevent the entry of foreign objects such as leaves, birds, etc.

CAUTION

Do not run unit during construction phase. Damage to internal components may result and void warranty.

WARNING

- Unit was factory tested. All blowers, fans, and compressors are set-up to run correctly when supplied power. If any one fan is running backwards or the compressor is making loud noises, immediately turn off the power. Switch two leads on the incoming power to the disconnect. This will ensure proper operation of the unit. Failure to comply may damage the compressors and void the warranty.
- Do not jumper any safety devices when operating the unit. This may damage components within or cause serious injury or death.

Every installation requires a comprehensive start-up to ensure proper operation of the unit. As part of that process, the following checklist must be completed and information recorded. Starting up the unit in accordance with this checklist will not only ensure proper operation, but will also provide valuable information to personnel performing future maintenance. Should an issue arise which requires factory assistance, this completed document will allow unit experts to provide quicker resolve. Qualified personnel should perform start-up to ensure safe and proper practices are followed.

Unit Documentation Record

Unit Model No. _____

Unit Serial No. _____

Energy Wheel Date Code _____

Start-Up Date _____

Start-Up Personnel Name _____

Start-Up Company _____

Phone Number _____

Pre-Start-Up Checklist

- Disconnect and lock-out all power switches.
- Remove any foreign objects that are located in the energy recovery unit.
- Check all fasteners, set-screws, and locking collars on the fans, bearings, drives, motor bases and accessories for tightness.
- Rotate the fan wheels and energy recovery wheels by hand and ensure no parts are rubbing.
- Check the fan belt drives for proper alignment and tension.
- Filters can load up with dirt during building construction. Replace any dirty pleated filters and clean the aluminum mesh filters in the intake hood.
- Verify that non-motorized dampers open and close properly.
- Check the tightness of all factory wiring connections.
- Verify control wire gauge.
- Verify diameter seal settings on the energy recovery wheel.

SPECIAL TOOLS

- Volt meter
- Incline manometer or equivalent
- Tachometer
- Amperage meter

Start-Up Checklist

Line Voltage. Check at unit disconnect.

L1-L2 _____ Volts

Motor Amp Draw

Supply Motor Amps L1 _____ Amps L2 _____ Amps

Exhaust Motor Amps L1 _____ Amps L2 _____ Amps

Fan RPM

Supply Fan RPM _____

Exhaust Fan RPM _____

Correct fan rotation direction?

Supply Fan Yes / No

Exhaust Fan Yes / No

Energy Wheel Motor

L1 _____ Amps L2 _____ Amps

Outdoor Air Temperature _____ °F

Return Air Temperature _____ °F

Outdoor Air Relative Humidity _____ % RH

Return Air Relative Humidity _____ % RH

System Start-Up - *continued*

General

Check all fasteners and set screws for tightness. This is especially important for bearings and fan wheels. Also, if dampers are not motorized, check that they open and close without binding.

Check Voltage

Before starting the unit compare the supplied voltage with the unit's nameplate voltage and the motor voltage.

Energy Recovery Wheel

First, follow the instructions for pulling the energy recovery cassette halfway out of the unit.

Air Seals — turn the energy recovery wheel by hand to verify free operation. Check that the air seals, located around the outside of the wheel and across the center (both sides of wheel), are secure and in good condition.

Air seals which are too tight will prevent proper rotation of the energy recovery wheel. Recheck the air seals for tightness. Air seal clearance may be checked by placing a sheet of paper, like a feeler gauge, against the wheel face. To adjust the air seals, loosen all eight seal retaining screws. These screws are located on the bearing support that spans the length of the cassette through the wheel center. Tighten the screws so the air seals tug slightly on the sheet of paper as the wheel is turned.

Replace cassette into unit, plug in wheel drive, replace access door and apply power. Observe that the wheel rotates freely. If wheel does not rotate or is binding, remove the cassette; instructions provided on page 13.

Check Blower Wheel Rotation

First, hand rotate the blower to ensure that the wheel is not rubbing against the scroll. If the blower is rotating in the wrong direction, the unit will move some air but not perform properly.

To check the rotation, open the blower access panel, which is labeled either supply or exhaust, and run the blower momentarily to determine the rotation.

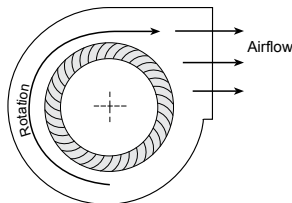

Forward Curved

Air Volume Check and Measurement

Along with the building balance, the unit's airflow (cfm) should be measured and compared with its rated air volume. The MiniVent is direct drive, therefore balancing dampers or speed controls are required for airflow balancing. Air volume measurement must be conducted with access doors on the unit.

The most accurate way to measure the air volume is by using the pitot traverse method in the ductwork away from the blower. Other methods can be used but should be proven and accurate.

To adjust the air volume, change the fan rpm or the system static pressure. See Troubleshooting section in this guide.

With all access panels on the unit, compare measured amps to the motor nameplate full load amps and correct if overamping.

Measure Motor Voltage, Amperage and Fan RPM

All access doors must be installed, run the measurement leads through the provided electrical access hole in the bottom access panel of the MiniVent. Measure and record the input voltage and motor amperage(s).

To measure the fan rpm, the blower door will need to be removed. Minimize measurement time because the motor may overamp with the door removed. *Do not operate units with access doors/panels open as the motors will overload.*

With all access panels on the unit, compare measured amps to the motor nameplate full load amps and correct if overamping.

Routine Maintenance

WARNING

Disconnect all electrical power to the MiniVent prior to inspection or servicing. Failure to comply with this safety precaution could result in serious injury or death. Improper installation, adjustment, alteration, service or maintenance can cause property damage, injury or death. Read the installation, operating, and maintenance instructions thoroughly before installing or servicing this equipment.

After the MiniVent has been put into operation, an annual inspection and maintenance program should be set-up to preserve reliability and performance.

The MiniVent energy recovery ventilator requires very little maintenance. However, small problems left unchecked, over time, could lead to loss of performance or early motor failure. We recommend that the unit be inspected once or twice a year.

Fasteners and Set Screws

Any fan vibration has a tendency to loosen mechanical fasteners. A periodic inspection should include checking all fasteners and set screws for tightness. Particular attention should be paid to set screws attaching the fan wheel to the shaft and the shaft to the bearings. Loose bearing set screws will lead to premature failure of the fan shaft.

Removal of Dust and Dirt

The fan motor and wheel(s) should be checked for dust and dirt accumulation. Dirt buildup clogs cooling openings on the motor housing and causes motor overheating. Dirt buildup can contaminate bearing lubricant and collect on fan wheel blades causing loss of performance or premature failure. Cleaning can be accomplished by brushing off any dust that may have accumulated. Under no circumstances should motors or bearings be sprayed with steam or water. Even filtered units can accumulate build up and should be checked when cleaning filters.

Maintenance to these components is achieved through the provided access panels.

Internal Filter Maintenance

Opening the access panel provides access to the one inch deep, pleated MERV 8 (30% efficient) filters. These filters should be checked regularly and cleaned or replaced as needed.

MiniVent	Internal Filter Size (in.)	Quantity
450	14 x 20	2
750	16 x 20	2

Energy Wheel

Annual inspection of the energy recovery wheel is recommended. MiniVent units ventilating smoking lounges and other non-clean air spaces should have energy recovery wheel inspections more often based upon need.

Accessing the Energy Recovery Wheel

Disconnect power to the MiniVent. Remove access panel labeled "Energy Wheel Cassette Access". **Unplug** the wheel drive motor. Pull the cassette halfway out.

Removing the Energy Recovery Wheel

First, remove the drive belt and the collars on both bearings. On the pulley side of the cassette remove the four (4) fasteners that hold the bearing support channel in place. Once the bearing support is removed the wheel can be pulled from the cassette. To replace the wheel reverse this procedure.

Recommended Cleaning Procedure

First, remove the energy recovery wheel by following the instructions.

Only excessive buildup of foreign material needs to be removed. Discoloration and staining of energy recovery wheel does not affect its performance.

Thoroughly spray wheel matrix with household cleaner such as Fantastik® or equivalent. Gently rinse with warm water and using a soft brush remove any heavier accumulation. A detergent/water solution can also be used. Do not use aggressive organic solvents, such as acetone. After cleaning is complete, shake the excess water from the wheel.

Frequency of Cleaning

A regular cleaning cycle must be established for the energy recovery wheel in order to maintain optimum sensible and latent energy transfer. In reasonably clean environments such as schools, offices or retail stores, the energy recovery wheel should be inspected annually and cleaned as needed.

For applications experiencing unusually high levels of tobacco smoke, such as lounges, nightclubs, bars and restaurants, washing of the energy recovery wheel every three months may be necessary to maintain latent energy (water vapor) transfer efficiency.

Failure to follow a regular cleaning cycle for the energy recovery wheel can result in significant energy transfer performance losses.

Energy Recovery Wheel Belt Drive

Drive belt(s) should be inspected annually. Normal operation eventually causes stretching or wear on the belt(s). Once this occurs the belt(s) should be replaced.

Replacement or spare energy wheel drive belt kits are available and ship with their own instructions. The serial number and date code of the energy wheel cassette are required to obtain the proper replacement belt kit from the factory. The energy wheel serial number and date code are located on a label above the drive pulley on the energy wheel cassette.

Standard Components

Vari-Green® Electronically Commutated Motor

Features

- Soft Start – All motors feature soft-start technology which eliminates inrush current at start-up. The motors will reliably start at any speed setting.
- Overload Protection – If the motor becomes overloaded, it will automatically reduce its speed until it is no longer overloaded. This means that the motor will never operate in the “service factor” which is possible with many AC motors.
- Locked Rotor Protection – If the motor ever encounters a locked-rotor scenario, the motor will automatically shut itself down. It will try to restart up to 3 times and if after the 3rd time the motor will still not rotate, the motor will not attempt to start again until power is cycled.
- Thermal Protection – The motors will have an internal thermal protection which electronically regulates the RPM limit until an acceptable temperature is met.



Operation and Wiring

These motors have the ability to accept a plug in potentiometer for speed adjustment AND the ability to accept a 0-10V signal for remote control.

- Motor Potentiometer - Turn the dial with your fingers to adjust. To increase the speed, rotate the dial clockwise. To decrease the speed, rotate the dial counterclockwise. Turning the dial full counterclockwise will turn the motor off.
- 0-10 VDC Signal - From 0-1.9V, the motor will be off and will operate within the 2-10V range. This motor does not require 24V power for operation.

Dampers

Gravity backdraft dampers are always included at the discharge positions.

Troubleshooting

Symptom	Possible Cause	Corrective Action
Unit is NOT operating	Electrical	Check fuses/circuit breakers, replace if needed. Check for On/Off switches. Check for correct supply voltage.
	Motor	Check motor horsepower is correct and not tripping overloads.
Excessive noise	Fan wheel rubbing on inlet	Adjust wheel and/or inlet cone. Tighten wheel hub or bearing collars on shaft.
	Bearings	Replace defective bearing(s). Lubricate bearings. Tighten collars and fasteners.
	Wheel out of balance	Clean, replace or rebalance.
Low airflow (cfm)	Fan speed too low	Check for correct rpms with catalog data.
	Fan wheels are operating backwards	Refer to Blower Wheel Rotation information on page 12.
	Dirty filters or energy wheel	Replace filters and/or follow the cleaning procedures.
	High static pressure	Incorrect fan-to-duct connections. Make sure dampers open appropriately. Increase fan speed
High airflow (cfm)	Fan speed too high	Check for correct fan rpm.
	Low static pressure	Make sure grilles, filters and access doors are installed. Decrease fan speed.
Energy wheel does NOT turn	Air seals too tight	Refer to Energy Recovery Wheel, Air Seals on page 12.
	No power to wheel motor	Make sure wheel drive is plugged in/connected. Verify power is available.
	Wheel drive belt	Check for loose or broken belts. Replace belts; consult factory.
Energy wheel runs intermittently	Wheel motor overloads are tripping due to rubbing between wheel and air seals.	Recheck air seals, make sure they are not too tight. See Energy Recovery Wheel, Air Seals on page 12.

Always provide the unit model and serial number when requesting parts or service information. Always check motor amps and compare to nameplate rating.

Maintenance Log

Date _____ Time _____ AM/PM

Notes: _____

Date _____ Time _____ AM/PM

Notes: _____

Date _____ Time _____ AM/PM

Notes: _____

Date _____ Time _____ AM/PM

Notes: _____

Date _____ Time _____ AM/PM

Notes: _____

Date _____ Time _____ AM/PM

Notes: _____

Date _____ Time _____ AM/PM

Notes: _____

Date _____ Time _____ AM/PM

Notes: _____

Our Commitment

As a result of our commitment to continuous improvement, Greenheck reserves the right to change specifications without notice.

Product warranties can be found online at Greenheck.com, either on the specific product page or in the literature section of the website at Greenheck.com/Resources/Library/Literature.

Greenheck's Energy Recovery Ventilators, Preconditioners, Models MiniVent, ERV, ERVe, MiniCore, ECV and ERM catalog provides additional information describing the equipment, fan performance, available accessories, and specification data.

AMCA Publication 410-96, Safety Practices for Users and Installers of Industrial and Commercial Fans, provides additional safety information. This publication can be obtained from AMCA International, Inc. at www.amca.org.

