

Installation, Operation and Maintenance Manual

Please read and save these instructions for future reference. Read carefully before attempting to assemble, install, operate or maintain the product described. Protect yourself and others by observing all safety information. Failure to comply with these instructions will result in voiding of the product warranty and may result in personal injury and/or property damage.



Table of Contents

Pre-Installation Guidelines	2
Installation for Control Dampers	2
Face and Bypass	4
Blade Orientation for Round Dampers	5
Maintenance	6
Troubleshooting	6

Receiving and Handling

Upon receiving dampers, check for both obvious and hidden damage. If damage is found, record all necessary information on the bill of lading and file a claim with the final carrier. Check to be sure that all parts of the shipment, including accessories, are accounted for.

Dampers must be kept dry and clean. Indoor storage and protection from dirt, dust and the weather is highly recommended. Do not store at temperatures in excess of 100°F (38°C).

Safety Warning

Improper installation, adjustment, alteration, service or maintenance can cause property damage, injury or death. Read the installation, operating, and maintenance instructions thoroughly before installing or servicing this equipment.

Electrical Guidelines

Electrical Guidelines

All wiring shall be done in accordance with the National Electrical Code ANSI/NFPA-70 latest edition, any local codes that may apply, and wiring diagrams developed in compliance with the job or project design and specifications

Important!

Electrical input may be needed for this equipment. This work should be performed by a qualified electrician. Verify power before wiring actuator. Greenheck is not responsible for any damage to, or failure of the unit caused by incorrect field wiring. To avoid causing death or serious bodily harm to building occupants, follow all instructions carefully. Dampers must close completely to preserve the integrity of the fire smoke separation.

Pre-Installation Guidelines

The basic intent of a proper installation is to secure the volume control damper into the opening in such a manner as to prevent distortion and disruption of damper operation. The following items will aid in completing the damper installation in a timely and effective manner.

- 1) Check schedules for proper damper locations within the building. Visually inspect the damper for damage.
- 2) Lift or handle damper using sleeve or frame. Do not lift damper using blades, linkage, actuators, or jackshifting. When handling multiple section assemblies, use sufficient support to evenly lift at each section mullion (see drawing). Do not drag, step on, apply excessive bending, twisting, or racking.
- 3) Do not install screws in damper frame that will interfere with unexposed blade linkage and prevent damper blades from opening and/or closing.
- 4) Damper must be installed into duct or opening square and free of twist or other misalignment. Damper must not be squeezed or stretched into duct or opening. Out of square, racked, twisted or misaligned installations can cause excessive leak; to exceed damper/actuator design.
- 5) Damper and actuator must be kept clean, dry and protected from dirt, dust and other foreign materials prior to and after installation. Examples of such foreign materials include but are not limited to:
 - a) Mortar dust
 - b) Drywall dust
 - c) Firesafing materials
 - d) Wall texture
 - e) Paint overspray
- 6) Damper should be sufficiently covered as to prevent overspray if wall texturing or spray painting will be performed within 5 feet (1.50m) of the damper. Excessive dirt or foreign material deposits on damper can cause excessive leakage and/or torque requirements to exceed damper/actuator design.
- 7) ACCESS: Suitable access (actuator maintenance, etc.) must be provided for damper inspection and servicing. Where it is not possible to achieve sufficient size access, it will be necessary to install a removable section of duct.
- 8) Applications where airflow could be uneven, such as a discharge fan, it is imperative to verify that at no point the maximum velocity exceeds the damper cataloged velocity.

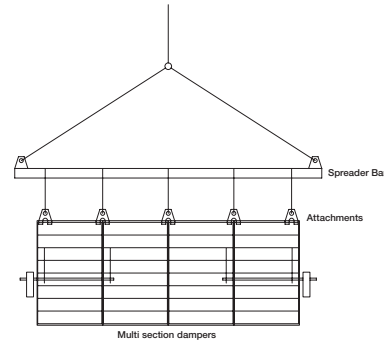

Installation for Control Dampers

- 1) Dampers ordered with "nominal" sizing are undersized ¼ in. (6mm) to facilitate ease of installation. For example, a 12 in. x 12 in. (305mm x 305mm) nominal damper will measure 11¾ in. x 11¾ in. (298mm x 298mm). Dampers ordered with "actual" sizing are not undersized. The duct or barrier opening that the damper is being mounted in should be ¼ in. (6mm) larger than the damper dimensions in both width and height. The opening should also be straight and level (**Figure 1**).

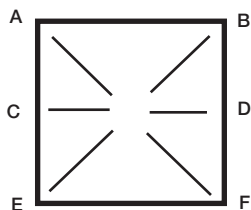

$$AF=BE$$

$$AB=CD$$

Do not twist or bow. Mount damper plumb in the opening.

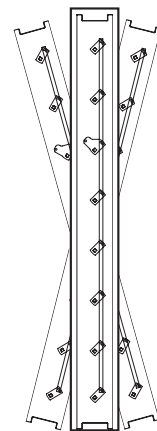

Figure 1

- 2) All installations require the entire exterior perimeter of the damper assembly to be secured to structural supports (example: concrete block wall, structural steel, etc.) which is supplied by others. The fastening method used to secure the damper to the structural support and the design of the structural support is the responsibility of field engineers.
- 3) Due to shipping constraints, some large damper assemblies may ship in multiple sections and require field assembly. The damper sections must be attached together with #14 sheet metal screws, ¼ in. (6mm) diameter nuts and bolts, tack or spot welds, or ⅜ in. (4mm) diameter steel pop rivets. Attachments must be spaced a maximum of 12 in. (305mm) on center and a maximum of 2 in. (51mm) from corners. Attachments must be made on front face and back face (air entering and air exiting side) of damper sections. **Figure 2**

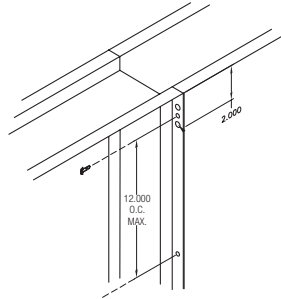

Figure 2

- 4) Multiple section VCD damper assemblies may require additional structural support between the sections based on the following criteria:
- a) Single section wide x unlimited sections high assembly:
 - No additional structural support is required between sections
 - b) Unlimited sections wide x single section high assemblies:
 - No additional structural support is required between sections
 - c) Two section wide x two section high assemblies:
 - Pressures up to and including 4 in. wg (1 kPa): a 14 gauge (2mm) 5 in. (127mm) wide horizontal steel mullion plate spanning the entire width of the damper assembly is required between the top and bottom sections.
 - Pressures above 4 in. wg (1 kPa) (see submittals for model specific pressure limitations): a 14 gauge (2mm) 7½ in. (191mm) wide horizontal steel mullion plate required between top and bottom sections.

Note: For vertical blade models, in lieu of the horizontal mullion plates, a vertical mullion plate is required between left and right sections.
 - d) Three or four section wide x two section high assemblies:
 - Pressures up to and including 6 in. wg (1.5 kPa)- Full length 8 in. wide mullion assembly. **Figure 3.**
 - Pressures above 6 in. wg (1.5 kPa) (see submittals for model specific pressure limitations): Structural supports shall be provided such that there are no unsupported banks of dampers more than two sections wide by two sections high. Two section wide x two section high banks shall have mullion plates as required by sections 4a - 4c.

Note: For vertical blade damper models, in lieu of the horizontal mullion plates, a vertical mullion plate is required between left and right sections.
 - e) Assemblies larger than four sections wide x two sections high:
 - Structural supports shall be provided such that there are no unsupported banks of dampers more than four sections wide by two sections high. Individual banks shall have mullion plates as required by sections 4a - 4d.

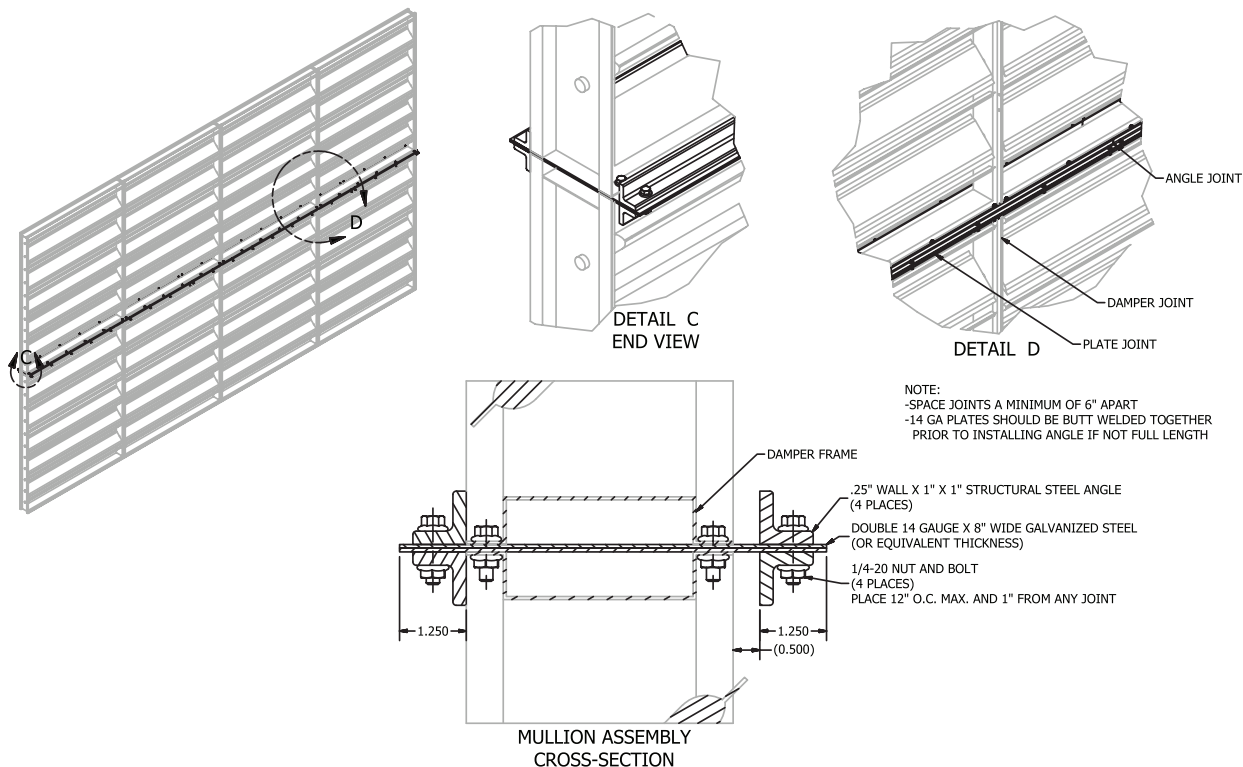

Figure 3: Mullion assembly for damper units 3 or 4 sections wide x 2 section high and pressures 6 in. wg or less

- 5) If the damper actuator is to be mounted out of the airstream, the extension pin should extend approximately 6 in. (152mm) beyond the frame. On jackshafted units, the jackshaft should extend through the jackshaft bearing assembly approximately 6 in. (152mm) beyond the frame.
- 6) Individual damper sections, as well as entire multiple section assemblies must be completely square and free from racking, twisting, or bending. Measure diagonally from upper corners to opposite lower corners of each section.
- 7) Damper blades, axles, and linkage must operate without binding. Before system operation, cycle dampers after installation to assure proper operation. On multiple section assemblies, all sections should open and close simultaneously.

Note: For vertical damper installation, blades must be horizontal. If vertical blades are needed, a vertical blade damper is required (example: VCD-23V). These dampers are built to ensure the jamb seal does not get crushed.

Face & Bypass

When the height of a face & bypass vertical style (FBV) is greater than 84 in. (2134mm), the damper sections are shipped separate, requiring field assembly. Before fastening damper sections together, the non-actuated damper section will need to be flipped upside down so that the linkage is on the same side as the actuated damper. After damper sections are fastened together, attach interconnecting angle as shown in **Figure 4**.

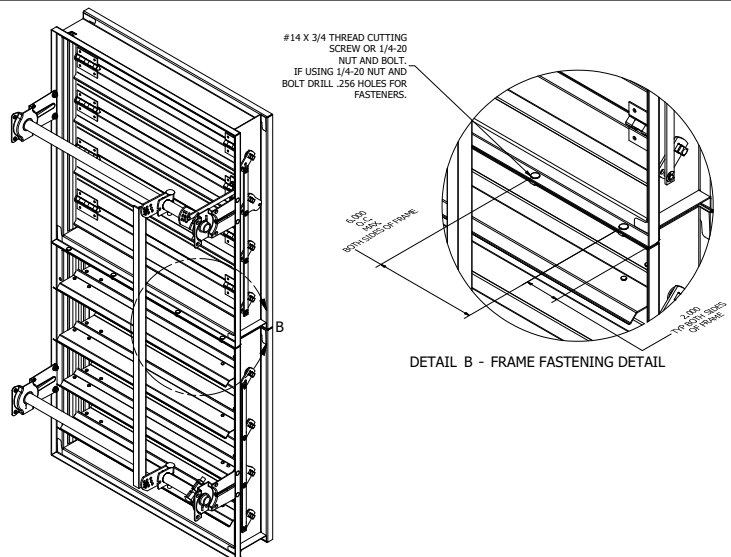
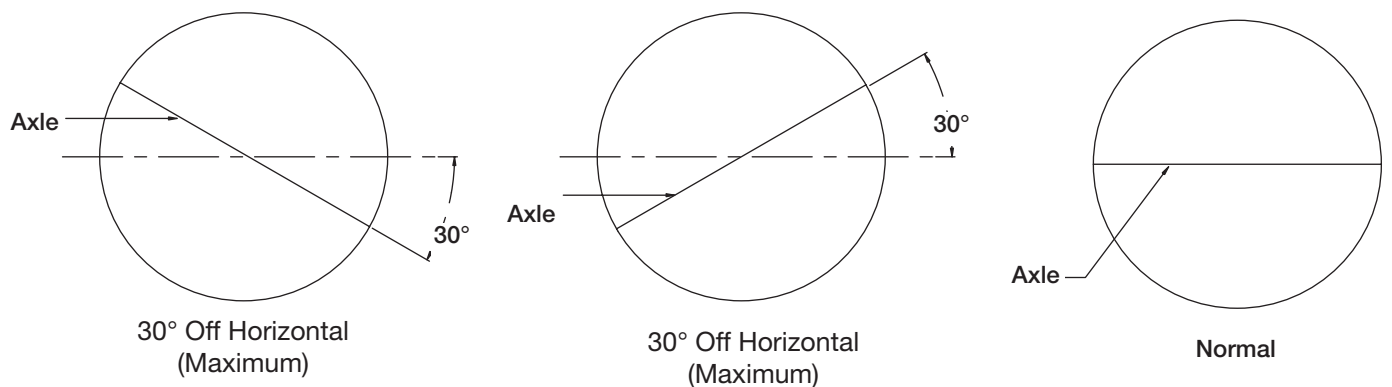

Figure 4

Damper Model	Maximum Single Section Size W x H in. (mm)	Maximum Overall Size for Multi-Section Dampers
VCD-20, VCD-23, SEVCD-23	48 x 74 (1219 x 1880)	Unlimited
VCD-33, VCD-34, VCD-40, VCD-42, SEVCD-33	60 x 74 (1524 x 1880)	Unlimited
VCD-43	60 x 74 (1524 x 1880)	288 x 222 (7315 x 5639)
VCD-23V	74 x 48 (1879 x 1219)	148 x 96 (3759 x 2438)
VCD-33V, VCD-34V, VCD-43V	74 x 60 (1879 x 1524)	148 x 120 (3759 x 3048)
VCDR-50, VCDR-53	24 in. (610mm)	-
VCDRM-53	48 in. (1219mm)	-
FBH-33 FBH-43	Face: 60 x 74 (1524 x 1880) Bypass: 60 x 74 (1524 x 1880)	Face: 96 x 74 (2438 x 1880)
FBV-33 FBV-43	Face: 60 x 74 (1524 x 1880) Bypass: 60 x 74 (1524 x 1880)	Face: 120 x 74 (3048 x 1880) Bypass: 120 x 74 (3048 x 1880)
FBH-23	Face: 48 x 74 (1219 x 1880) Bypass: 48 x 74 (1219 x 1880)	Face: 96 x 74 (2438 x 1880)
FBV-23	Face: 48 x 74 (1219 x 1880) Bypass: 48 x 74 (1219 x 1880)	Face: 96 x 74 (2438 x 1880) Bypass: 96 x 74 (2438 x 1880)

Blade Orientation for Round Control Dampers



Damper Maintenance

Greenheck's dampers are designed to be trouble free and hassle free under normal operation. Dampers are to be installed square and straight so as to prevent binding during operation. The following annual damper maintenance suggestions will help to ensure proper damper operation and increase the life expectancy of the damper.

- Foreign Matter** Over the course of time, dirt and grime may collect on damper surfaces. The damper surfaces should be cleaned to prevent hindrance to airflow.
- Moving Parts** Make sure that parts such as linkage, bearings, blades, etc. that are intended to move freely, can do so. Lubricating these components can prevent possible rusting and unnecessary friction increase. Use only a moli-spray oil or similar graphite based oil as regular lubricating oil will attract dirt.
- Bearings: Synthetic, oil impregnated, and ball bearings (without grease fittings) do not require lubrication. Ball bearings with grease fittings require only minimal grease.
- Closure** Remove foreign materials that may be interfering with blade closure or effective sealing of the blades with each other or with the frame.
- Operation** While operating the damper through its full cycle, check to see that the blades open and close properly. If there is a problem, check for loose linkage, especially at the actuator. Tighten the linkage where required.

Troubleshooting

The following is a cause and correction list for common concerns with the dampers.		
Symptom	Possible Cause	Corrective Action
Damper does not fully open and/or fully close	Frame is 'racked' causing blades to bind on jamb seals	Adjust frame such that it is square and plumb
	Actuator linkage loose	Close damper, disconnect power, adjust and tighten linkage
	Defective motor	Replace
	Screws in damper linkage	Locate screws and remove
	Actuator linkage hitting wall or floor	Damper installed too far into wall. Move out to line designated on damper label
	Contaminants on damper	Clean with a non oil-based solvent (see Damper Maintenance)
Actuator runs hot or makes a humming noise	Actuator prohibited from reaching end of stroke	Disconnect linkage from jackshaft, open damper, power actuator to end of spring, tighten linkage. Verify amp draw

Our Commitment

As a result of our commitment to continuous improvement, Greenheck reserves the right to change specifications without notice.

Product warranties can be found online at Greenheck.com, either on the specific product page or in the literature section of the website at Greenheck.com/Resources/Library/Literature.

