

Installation, Operation and Maintenance Manual

Please read and save these instructions for future reference. Read carefully before attempting to assemble, install, operate or maintain the product described. Protect yourself and others by observing all safety information. Failure to comply with these instructions will result in voiding of the product warranty and may result in personal injury and/or property damage.

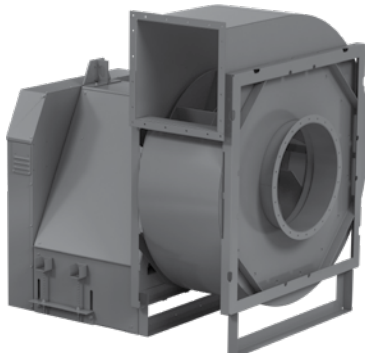

IP

General Safety Information

Only qualified personnel should install this fan. Personnel should have a clear understanding of these instructions and should be aware of general safety precautions. Improper installation can result in electric shock, possible injury due to coming in contact with moving parts, as well as other potential hazards. Other considerations may be required if high winds or seismic activity are present. If more information is needed, contact a licensed professional engineer before moving forward.

1. Follow all local electrical and safety codes, as well as the National Electrical Code (NEC), the National Fire Protection Agency (NFPA), where applicable. Follow the Canadian Electric Code (CEC) in Canada.
2. The rotation of the wheel is critical. It must be free to rotate without striking or rubbing any stationary objects.
3. Motor must be securely and adequately grounded.
4. Do not spin fan wheel faster than max cataloged fan rpm. Adjustments to fan speed significantly effects motor load. If the fan RPM is changed, the motor current should be checked to make sure it is not exceeding the motor nameplate amps.
5. Do not allow the power cable to kink or come in contact with oil, grease, hot surfaces or chemicals. Replace cord immediately if damaged.
6. Verify that the power source is compatible with the equipment.
7. Never open access doors to a duct while the fan is running.

DANGER

Always disconnect, lock and tag power source before installing or servicing. Failure to disconnect power source can result in fire, shock or serious injury.

CAUTION

When servicing the fan, motor may be hot enough to cause pain or injury. Allow motor to cool before servicing.

CAUTION

Precaution should be taken in explosive atmospheres.

DANGER

Pour écarter les risques d'incendie, de choc électrique ou de blessure grave, veiller à toujours débrancher, verrouiller et étiqueter la source de courant avant l'installation ou l'entretien.

ATTENTION

Lors de toute intervention sur la soufflante, le moteur peut être suffisamment chaud pour provoquer une douleur voire une blessure. Laisser le moteur refroidir avant toute maintenance.

ATTENTION

Faire preuve de précaution dans les atmosphères explosives.

Receiving

Upon receiving the product check to make sure all items are accounted for by referencing the delivery receipt or packing list. Inspect each crate for shipping damage before accepting delivery. Notify the carrier if any damage is noticed. The customer will make a notation of damage (or shortage of items) on the delivery receipt acknowledging any damage to the product. All damage should be noted on all the copies of the bill of lading which is countersigned by the delivering carrier. If damaged, immediately contact your local representative. Any physical damage to the unit after acceptance is not the responsibility of manufacturer.

Unpacking

Verify that all required parts and the correct quantity of each item have been received. If any items are missing, report shortages to your local representative to arrange for obtaining missing parts. Sometimes it is not possible that all items for the unit be shipped together due to availability of transportation and truck space. Confirmation of shipment(s) must be limited to only items on the bill of lading.

Handling

Fans are to be rigged and moved by the lifting brackets provided or by the skid when a forklift is used. Location of brackets varies by model and size. Handle in such a manner as to keep from scratching or chipping the coating. Damaged finish may reduce the ability of the fan to resist corrosion. Fans should never be lifted by the shaft, fan housing, motor, belt guard or accessories.

Storage

- Rotate fan wheel monthly and purge bearings once every three months.
- Energize fan motor once every three months.
- Store belts flat to keep them from warping and stretching.
- Store unit in location which does not have vibration.
- After storage period, purge grease before putting fan into service.

If storage of fan is in a humid, dusty or corrosive atmosphere, rotate the fan and purge the bearings once a month. Improper storage which results in damage to the fan will void the warranty.

Fans are protected against damage during shipment. If the unit cannot be installed and operated immediately, precautions need to be taken to prevent deterioration of the unit during storage. The user assumes responsibility of the fan and accessories while in storage. The manufacturer will not be responsible for damage during storage. These suggestions are provided solely as a convenience to the user.

INDOOR - The ideal environment for the storage of fans and accessories is indoors, above grade, in a low humidity atmosphere which is sealed to prevent the entry of blowing dust, rain, or snow. Temperatures

should be evenly maintained between 30°F to 110°F (-1°C to 43°C). Wide temperature swings may cause condensation and “sweating” of metal parts. All accessories must be stored indoors in a clean, dry atmosphere.

Remove any accumulations of dirt, water, ice or snow and wipe dry before moving to indoor storage. To avoid “sweating” of metal parts allow cold parts to reach room temperature. To dry parts and packages use a portable electric heater to get rid of any moisture build up. Leave coverings loose to permit air circulation and to allow for periodic inspection.

The unit should be stored at least 3½ in. (89 mm) off the floor on wooden blocks covered with moisture proof paper or polyethylene sheathing. Aisles between parts and along all walls should be provided to permit air circulation and space for inspection.

OUTDOOR - Fans designed for outdoor applications may be stored outdoors, if absolutely necessary. Roads or aisles for portable cranes and hauling equipment are needed.

The fan should be placed on a level surface to prevent water from leaking into the fan. The fan should be elevated on an adequate number of wooden blocks so that it is above water and snow levels and has enough blocking to prevent it from settling into soft ground. Locate parts far enough apart to permit air circulation, sunlight, and space for periodic inspection. To minimize water accumulation, place all fan parts on blocking supports so that rain water will run off.

Do not cover parts with plastic film or tarps as these cause condensation of moisture from the air passing through heating and cooling cycles.

Fan wheels should be blocked to prevent spinning caused by strong winds.

Inspection & Maintenance during Storage

While in storage, inspect fans once per month. Keep a record of inspection and maintenance performed.

If moisture or dirt accumulations are found on parts, the source should be located and eliminated. At each inspection, rotate the wheel by hand ten to fifteen revolutions to distribute lubricant on motor. If paint deterioration begins, consideration should be given to touch-up or repainting. Fans with special coatings may require special techniques for touch-up or repair.

Machined parts coated with rust preventive should be restored to good condition promptly if signs of rust occur. Immediately remove the original rust preventive coating with petroleum solvent and clean with lint-free cloths. Polish any remaining rust from surface with crocus cloth or fine emery paper and oil. Do not destroy the continuity of the surfaces. Wipe clean thoroughly with Tectyl® 506 (Ashland Inc.) or the equivalent.

For hard to reach internal surfaces or for occasional use, consider using Tectyl® 511M Rust Preventive or WD-40® or the equivalent.

Removing from Storage

As fans are removed from storage to be installed in their final location, they should be protected and maintained in a similar fashion until the fan equipment goes into operation.

Prior to assembly and installation of the unit and system components, inspect the fan assembly to make sure it is in working order.

1. Check all fasteners, set screws on the fan, wheel, bearings, drive, motor base and accessories for tightness.
2. Rotate the fan wheel by hand and assure no parts are rubbing. Access to the wheel is obtained through a bolted panel located on the side of the fan housing.
3. Ensure proper wheel settings for radial gap and alignment. Refer to Radial Gap, Overlap and Wheel Alignment section on page 8.

Table of Contents

General Safety Information	1
Receiving / Unpacking / Handling / Storage	2
Inspection and Maintenance during Storage.	2
Removing from Storage.	3
General Information.	4
Unit and System Identification Tags	4
Pre-Installation Information	4
Electrical Disconnects	4
Moving Parts	4
Guards / Access Doors.	4
Air Pressure and Suction	4
Fans - Rigging and Lifting.	5
Installation	6
Ducted Inlet Installations	6
Ducted Outlet Installations.	6
Non-Ducted Installations	6
Fan Drainage Piping and Trap Detail	7
Bases	7
Belt Guards	8
Electrical Connections	8
Radial Gap, Overlap and Wheel Alignment	9
Unit Start-Up.	10
Visual Inspection of Equipment	10
Additional Steps for Initial Start-Up	10
Vibration	10
Routine Maintenance	11
Motors	11
Shaft Bearings	11
Belt Drive Maintenance	12
Belt Adjustment	12
Variable Frequency Drive Operation	13
Field Coating Touch-Up Procedure.	13
Parts List	14
Troubleshooting.	15
Maintenance Log.	Backcover
Our Commitment.	Backcover

General Information

To ensure a successful installation, the instructions in this manual should be read and adhered to. Failure to comply with proper installation procedures may void the warranty.

Unit and System Identification Tags

Each fan has a permanently affixed manufacturer's engraved metal nameplate containing the model number and individual serial number.

The tag shown is an example of an identification nameplate on the fan. The information provides general details about the fan, as well as contains specific information unique to the unit. When contacting your local manufacturer's representative with future needs or questions, have the information on this label available. Tags are mounted in an area which is clearly visible, usually on the side of the fan cabinet.

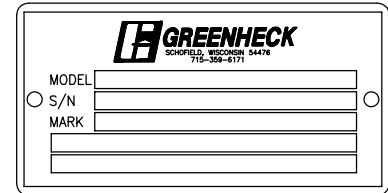

Pre-Installation Information

Before installation, it is important to be certain the mounting surface will bear the operating weight of the unit. For proper unit operation, it is also important that it be operated in a completely level position.

For further details on safety practices involving industrial and commercial fans, please refer to AMCA Publication 410.

Electrical Disconnects

All fan motors should have disconnects located in close visual proximity to turn off electrical service. Service disconnects shall be locked-out when maintenance is being performed.

Moving Parts

All moving parts must have guards to protect personnel. Refer to local codes for requirements as to the number, type and design. Fully secure fan wheel before performing any maintenance. The fan wheel may start "free wheeling" even if all electrical power has been disconnected. Before the initial start-up or any restart, check the following items to make sure that they are installed and secure.

- Do not spin fan wheel faster than the maximum cataloged fan RPM.
- Adjustments to fan speed significantly affects motor load. If the fan RPM is changed, the motor current should be checked to make sure it is not exceeding the motor nameplate amps.

Guards – Motor Cover, Weatherhood, Shaft, Belt, Inlet or Outlet Guard

Do not operate fans without proper protective devices in place. Failure to do so may result in serious bodily injury and property damage. Check local codes to ensure compliance for all protective devices.

Access Doors

Before opening access doors, ensure the fan wheel has stopped moving and that the wheel has been secured from being able to rotate. Do not operate fan without access door in its fully closed position.

Air Pressure and Suction

In addition to the usual hazards associated with rotating machinery, fans also create a dangerous suction at the inlet. Special caution needs to be used when moving around a fan, whether it is in operation or not. Before start-up, make sure the inlet area is clear of personnel and loose objects.

Fans - Rigging and Lifting

IMPORTANT

Fans should never be lifted by the shaft, motor, motor cover or accessories.

1. Before lifting, be sure that all shipping materials have been removed from the unit.
2. Use standard lifting and rigging practices.
3. ALL lifting brackets on each unit must be utilized at the same time.
4. Fan to be kept level during lifting and installation.
5. Spreader bars must span the unit to prevent damage to the unit by the lifting cables.
6. Always test-lift the unit to check for proper balance and rigging before hoisting to desired location.
7. Never lift unit in windy conditions.
8. Preparation of roof opening should be completed prior to lifting unit to the roof.

Fans are to be rigged and moved by the lifting brackets provided or by the skid when a forklift is used. Location of brackets varies by model and size. Handle in such a manner as to keep from scratching or chipping the coating. Damaged finish may reduce ability of fan to resist corrosion.

See coating repair section of this manual for details regarding touch-up of damaged surfaces.

IMPORTANT

Spreader bars are recommended to prevent damage to the unit. Failure to use spreader bars may result in damage which becomes the installer's responsibility.

Typical Arrangement 10 without Isolation Base

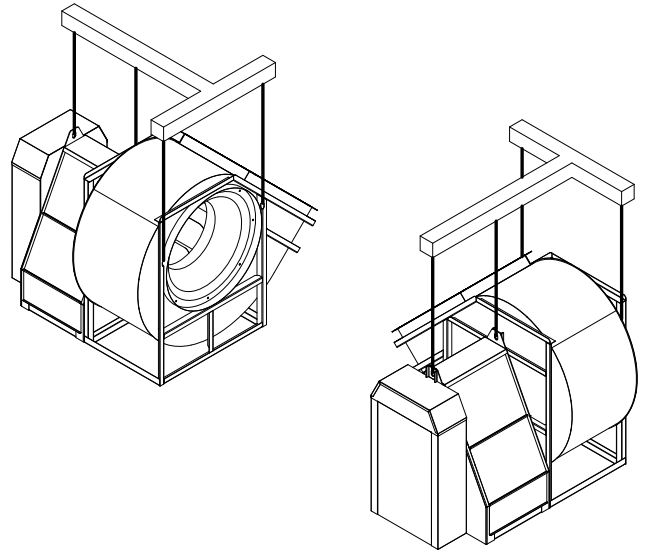

Typical Arrangement 4 Without Isolation Base

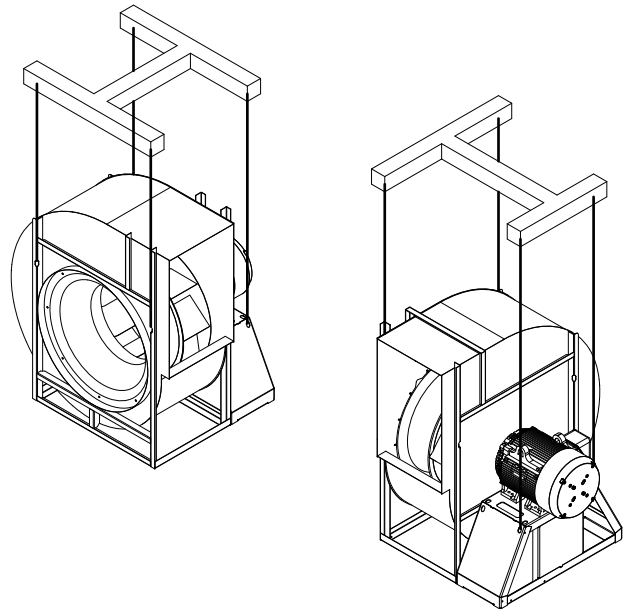

Typical with Isolation Base

If the fan assembly has an isolation base, lift the entire assembly by the four corner holes located in each corner of the base. This is the case for both the standard base or base with height savings bracket.

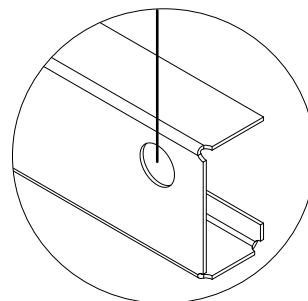

Isolation Base

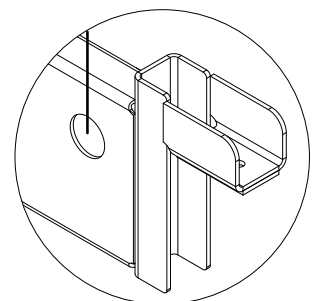

Isolation Base with Height Savings Bracket

Installation

Move the fan to the desired location. Check and tighten fasteners throughout the unit and then fasten securely through mounting holes provided in the base angles. The unit must be set level (shimming may be necessary). Flexible duct connections and vibration isolators should be used where noise is a factor.

The motor voltage and ampere rating must be checked for compatibility with the electrical supply prior to final electrical connection. Supply wiring to the fan must be properly fused, and conform to local and national electrical codes.

Installations with inlet or discharge configurations that deviate from this standard may result in reduced fan performance. Restricted or unstable flow at the fan inlet can cause pre-rotation of incoming air or uneven loading of the fan wheel yielding large system losses and increased sound levels. Free discharge or turbulent flow in the discharge ductwork will also result in system effect losses. Refer to the following diagrams for the most efficient installation conditions.

Ducted Inlet Installations

Inlet Duct Turns - Installation of a duct turn or elbow too close to the fan inlet reduces fan performance because air is loaded unevenly into the fan wheel. To achieve full fan performance, there should be at least three fan wheel diameters between the turn or elbow and the fan inlet.

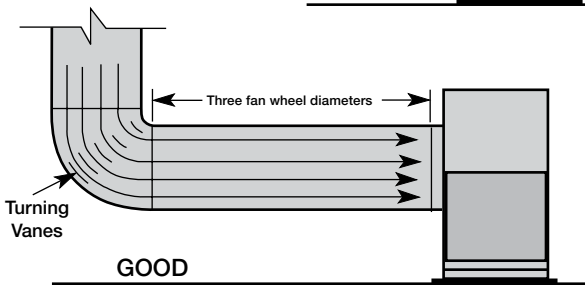
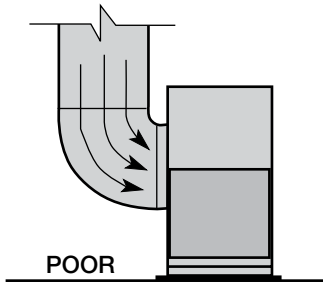

Inlet Spin - Inlet spin is a frequent cause of reduced fan performance. The change in fan performance is a function of the intensity of spin and not easily defined. The best solution is proper duct design and airflow patterns. Turning vanes reduce the effects of inlet spin.

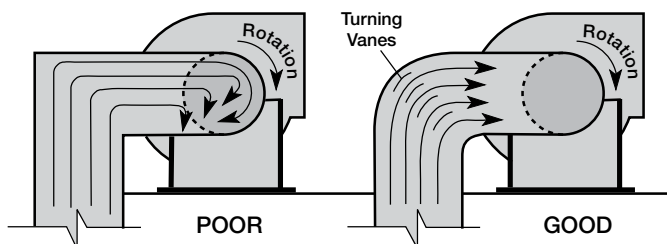

Ducted Outlet Installations

Discharge Duct Turns - Duct turns located near the fan discharge should always be in the direction of the fan rotation.

Fan performance is reduced when duct turns are made immediately off the fan discharge. To achieve cataloged fan performance there should be at least three equivalent duct diameters of straight ductwork between the fan discharge and any duct turns.

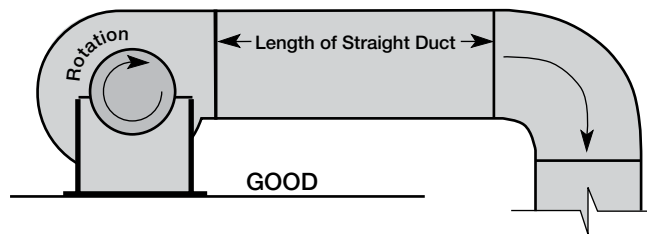
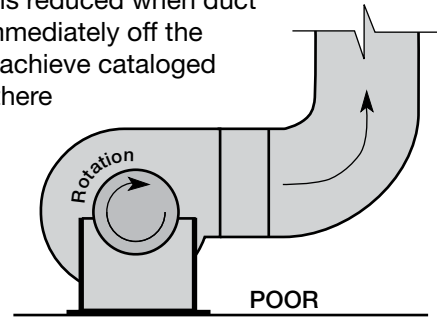

Non-Ducted Installations

Inlet Clearance - Installation of a fan with an open inlet too close to a wall or bulkhead will cause reduced fan performance. It is desirable to have one fan wheel diameter between parallel fan units and a minimum of three-fourths of a wheel diameter between the fan inlet and the wall.

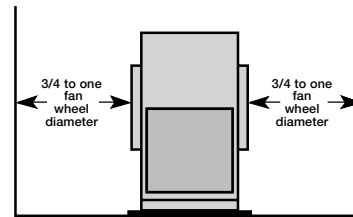

Single Fan Installation

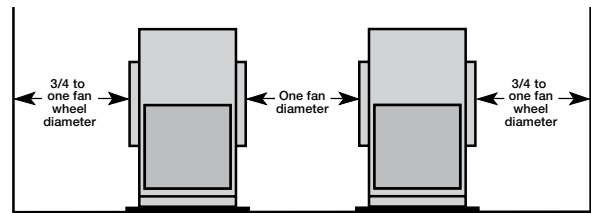

Parallel Fan Installation

Free Discharge - Free or abrupt discharge into a plenum results in a reduction in fan performance. The effect of discharge static regain is not realized.

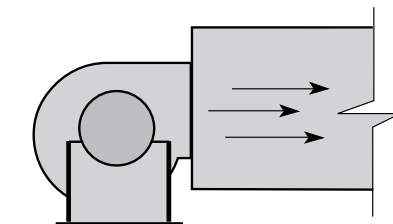

Fan Drainage Piping and Trap Detail (by others)

Fans may have been supplied with an optional drain. Drains are located at the underside of the scroll housing. The drain may need to be connected to a drainage system to ensure proper disposal of any water or condensate that may occur.

- Drain connections with and without a plug are 1 inch (25.4 mm)
- Installed piping to have a downward angle to allow for drainage.
- Fill traps to recommended level before start-up.

Note: A conservative method of trap design is to set N = total static pressure.

Positive Pressure Trap

Connect this end to fan drain.

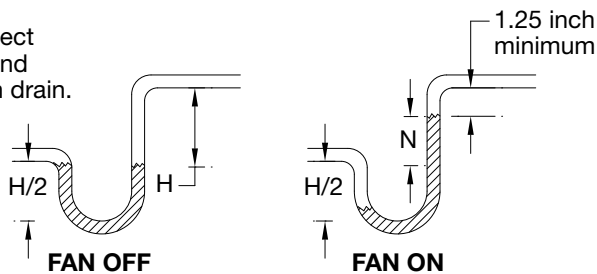

N = Negative fan pressure (inches W.C.)

H = N - 0.5 inches minimum

Check local codes for proper disposal of drain water which has been in contact with the exhaust air.

Fans used for grease exhaust need to be equipped with a separate grease collector.

Drain Options

- None
- Without plug

Bases (Foundation and Isolation)

Critical to every fan installation is a strong, level foundation. A reinforced poured concrete pad with a structural steel base or inertia base provides an excellent foundation. Structural bases must be sturdy enough, with welded construction, to prevent flexing and vibration.

To eliminate vibration and noise from being transferred to the building, vibration isolators should be used. The fan is mounted directly on the isolation base and must be supported for the entire length of the fan base angle (Refer to the Centrifugal Fan Isolation Base Assembly Instructions if the base was supplied by manufacturer). Isolators are installed between the isolation base and the foundation.

After the fan, isolation base, and isolators are installed, the entire assembly must be leveled.

Position the level on the isolation base, not the fan shaft, for proper leveling. Additionally, the motor and fan shafts must be level and parallel relative to each other for proper alignment.

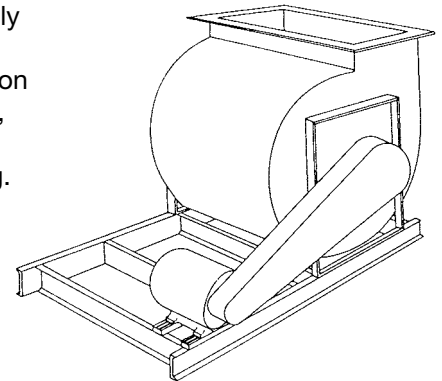

Typical Fan on Isolation Base

CAUTION

When installing a fan, ensure the proper protective devices are used to protect personnel from moving parts and other hazards. A complete line of protective accessories are available from the manufacturer including: inlet guards, outlet guards, belt guards, shaft guards, protective cages and electrical disconnects.

Electrical Disconnects

All fan motors should have disconnects located in close visual proximity to turn off electrical service. Service disconnects shall be locked out when maintenance is being performed.

Moving Parts

All moving parts must have guards to protect personnel. Refer to local codes for requirements as to the number, type and design. Fully secure fan wheel before performing any maintenance. The fan wheel may start "free wheeling" even if all electrical power has been disconnected. Before the initial start-up or any restart, check the guards (belt, shaft, inlet and outlet) and check the access doors to ensure that they are installed and secure.

Belt Guards

Greenheck offers various types of customized belt guards dependent upon fan model, arrangement and motor position. Motor position is determined from the drive side.

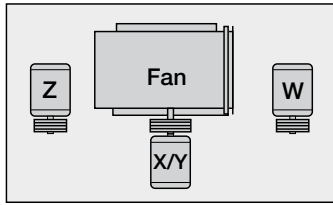

Motor position and fan rotation are determined from drive side

The various types of belt guards are shown in illustrations. If the guard is not purchased from Greenheck, they must be supplied by the installer or owner.

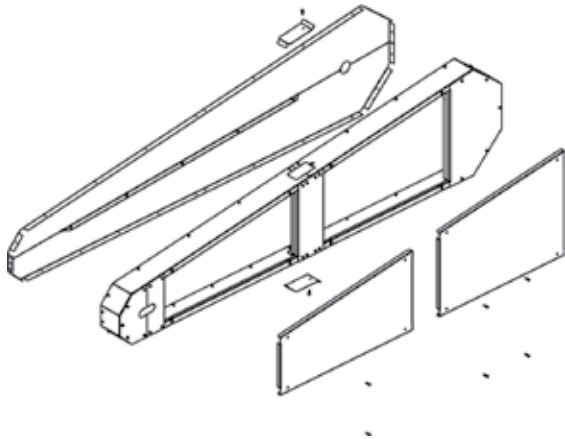

Typical Belt Guard

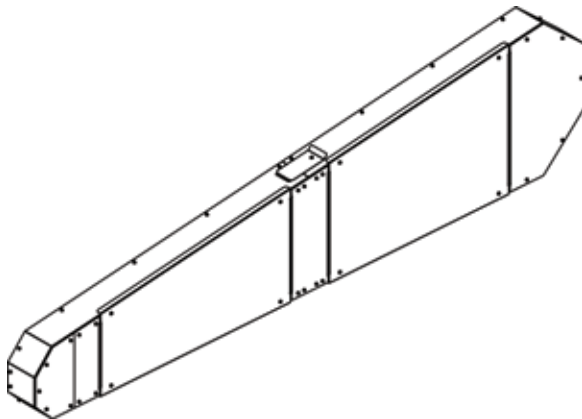

Industrial Process – Arr. 1 & 9

If the belt guard is not factory mounted or was not supplied by manufacturer, then it must be field mounted. Brackets and mounting hardware are the responsibility of the installer. The figures below illustrate suggested attachment points for belt guard mounting bracket locations. These locations vary with motor mounting position, arrangement, and fan type. The bearing supports and fan structure are used in most instances and when the motor is not mounted to the fan itself, a bracket should also be located near it. This information is intended only as a guide and actual field conditions may dictate another mounting location for the guard brackets. Refer to local codes for securing guarding.

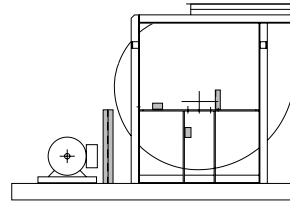

Motor Position: W/Z
Arrangement - 1, 3

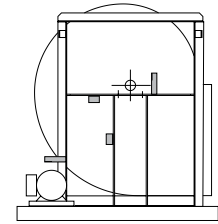

Motor Position: X/Y
Arrangement - 1, 3

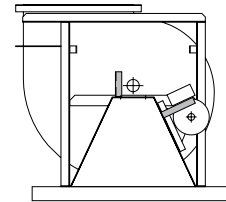

Motor Position: L/R
Arrangement 9

Suggested Belt Guard Attachment Points
(shaded gray)

Electrical Connections

Before electrical connections are made, the supply voltage, phase and ampere capacity must be checked for compatibility with the fan motor. In addition, the supply wiring must be properly fused and conform to local and national electrical codes. If the unit is supplied with a safety disconnect switch, ensure proper wiring to the fan motor. Be sure the disconnect is switched to the "OFF" position before connecting supply wires. If no disconnect is supplied, ensure the supply wire is not live before connection. Supply wires are then connected to the optional safety disconnect switch (if supplied) or motor.

Radial Gap, Overlap and Wheel Alignment

Efficient fan performance can be maintained by having the correct radial gap, overlap and wheel alignment. These items should be checked after the fan has been in operation for 24 hours and before start-up after the unit has been serviced. Radial gap and overlap information applies to IP with air handling wheel.

Unit Size	IP (Air Handling) Inlet Cone to Backplate			
	A Dimension ± Tolerance (in.)		Dimension ± Tolerance (mm)	
5	3.67	± 1/8	93	± 3
7	5.36	± 1/8	136	± 3
9	6.88	± 1/8	175	± 3
11	8.38	± 1/4	213	± 6
13	9.92	± 1/4	252	± 6
15	11.39	± 3/8	289	± 10
17	12.95	± 3/8	329	± 10
19	14.48	± 3/8	368	± 10
21	15.95	± 3/8	405	± 10
23	17.50	± 1/2	445	± 13
26	20.00	± 1/2	508	± 13
29	22.31	± 1/2	567	± 13
33	25.75	± 1/2	654	± 13
37	28.82	± 1/2	732	± 13
41	31.38	± 1/2	797	± 13

Radial Gap is adjusted by loosening the inlet cone bolts and centering the cone on the wheel. If additional adjustment is required to maintain a constant radial gap, loosening the bearing bolts and centering the wheel is acceptable as a secondary option.

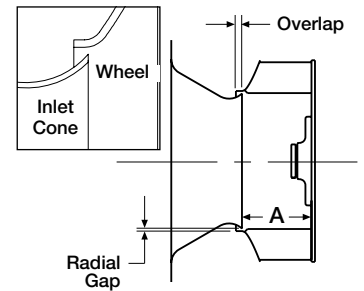

IP (Air Handling)

Overlap or offset, is adjusted by loosening the wheel hub from the shaft and moving the wheel to the desired position along the shaft.

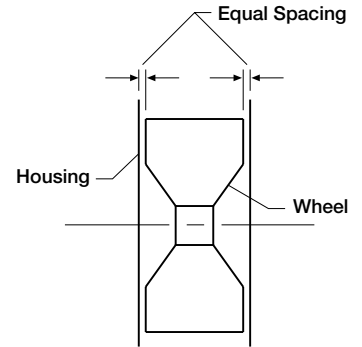

**Wheel Alignment
IP (Open Radial or Backplated)**

The transition between the inlet cone and wheel should be as shown; there is a smooth feel to the profile when moving from one component to the other. Overlap on double width fans is set by having equal spacing on each side of the wheel.

Correct **wheel alignment** for an industrial process fan (open radial or backplated/wool wheel) is achieved by centering the wheel in the housing.

Clockwise Rotation

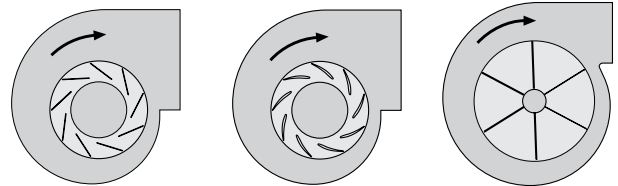

**Centrifugal
Backward Inclined**

**Centrifugal
Airfoil**

**Industrial Process
Radial Blade**

Always viewed from the drive side.

Unit Start-Up

Visual Inspection of Equipment

The equipment type and arrangement should be verified as ordered at once when it arrives at the job site. When a discrepancy is found, the local sales representative must be notified immediately so that corrective action may be investigated, also verify electrical conformance to specifications. Unauthorized alterations and unauthorized back charges will not be recognized by the manufacturer.

After the unit has been assembled, installed and all utilities have been hooked up, the unit is now ready for operation.

WARNING

Disconnect and secure to the "Off" position all electrical power to the fan prior to inspection or servicing. Failure to comply with this safety precaution could result in serious injury or death.

Before starting the unit, check the following:

1. Disconnect and lock-out all power switches to fan. See warning below.
2. Check all fasteners, set screws and locking collars on the fan, bearings, drive, motor base and accessories for tightness.
3. Rotate the fan wheel manually to be sure that it is free to operate. Remove any dirt or debris that may have accumulated during installation.
4. Check for bearing alignment and lubrication.
5. Check for coupling alignment (Arr. 8 only).
6. Check the V-belt drive for proper alignment and tension.
7. Check all guarding (if supplied) to ensure that it is securely attached and not interfering with rotating parts.
8. Check operation of variable inlet vanes or discharge dampers (if supplied) for freedom of movement.
9. Check all electrical connections for proper attachment.
10. Check housing and ductwork, if accessible, for obstructions and foreign material that may damage the fan wheel.

Additional Steps for Initial Start-Up

1. Check for proper wheel rotation by momentarily energizing the fan. Rotation is always determined by viewing the wheel from the drive side and should correspond to the rotation decal affixed to the unit. One of the most frequently encountered problems with centrifugal fans is motors which are wired to run in the wrong direction. This is especially true with 3-phase installations where the motor will run in either direction, depending on how it has been wired. To reverse rotation of a 3-phase motor, interchange any two of the three electrical leads. Single phase

motors can be reversed by changing internal connections as described on the motor label or wiring diagram.

2. If the fan has inlet vanes, they should be partially closed to reduce power requirements. This is especially important if the fan is designed for a high temperature application and is being started at room temperature.
3. Fans with multi-speed motors should be checked on low speed during initial start-up.
4. Check for unusual noise, vibration or overheating of bearings. Refer to the "Troubleshooting" section of this manual if a problem develops.
5. Grease may be forced out of the bearing seals during initial start-up. This is a normal self-purging feature of this type of bearing.

Vibration

Excessive vibration is the most frequent problem experienced during initial start-up. Left unchecked,

Common Sources of Vibration

1. Wheel unbalance
2. Drive pulley misalignment
3. Incorrect belt tension
4. Bearing / coupling misalignment
5. Mechanical looseness
6. Faulty belts
7. Drive component unbalance
8. Poor inlet / outlet conditions
9. Foundation stiffness

excessive vibration can cause a multitude of problems, including structural and/or component failure. Many of these conditions can be discovered

by careful observation. Refer to the troubleshooting section of this manual for corrective actions. If observation cannot locate the source of vibration, a qualified technician using vibration analysis equipment should be consulted. If the problem is wheel unbalance, in-place balancing can be done providing there is access to the fan wheel. Any correction weights added to the wheel should be welded to either the wheel back (single-plane balance) or to the wheel back and wheel cone (two-plane balance).

Greenheck performs a vibration test on all centrifugal fans before shipping. Three vibration readings are taken on each bearing in the horizontal, vertical, and axial directions. The allowable maximum vibration for belt drive units is 0.15 in/sec. peak velocity filter-in for rigid mount and 0.20 in/sec. peak velocity filter-in for flexible mount at the fan RPM per AMCA Standard 204. These vibration signatures are a permanent record of how the fan left the factory and are available upon request.

Generally, fan vibration and noise is transmitted to other parts of the building by the ductwork. To eliminate this undesirable effect, the use of heavy canvas connectors is recommended. If fireproof material is required, Flexweave™1000 - Type FN-30 can be used.

Routine Maintenance

WARNING

Before taking any corrective action, make certain unit is not capable of operation during repairs.

Once the unit has been put into operation, a routine maintenance schedule should be set up to accomplish the following:

1. Lubrication of bearings and motor (see below).
2. Wheel, housing, bolts and set screws on the entire fan should be checked for tightness.
3. Any dirt accumulation on the wheel or in the housing should be removed to prevent unbalance and possible damage.
4. Isolation bases should be checked for freedom of movement and the bolts for tightness. Springs should be checked for breaks and fatigue. Rubber isolators should be checked for deterioration.
5. Inspect fan impeller and housing looking for fatigue, corrosion or wear.

When performing any service to the fan, disconnect the electrical supply and secure fan impeller.

Motors

Motor maintenance is generally limited to cleaning and lubrication. Cleaning should be limited to exterior surfaces only. Removing dust and grease build up on the motor housing assists proper motor cooling. Never wash-down motor with high pressure spray.

Greasing of motors is only intended when fittings are provided. Many fractional motors are permanently lubricated for life and require no further lubrication.

Motors supplied with grease fittings should be greased in accordance with the manufacturer's recommendations.

CAUTION

When operating conditions of the fan are to be changed (speed, pressure, temperature, etc.), consult Greenheck to determine if the unit can operate safely at the new conditions.

Shaft Bearings

The bearings for Greenheck fans are carefully selected to match the maximum load and operating conditions of the specific class, arrangement, and fan size. The instructions provided in this manual and those provided by the bearing manufacturer will minimize any bearing problems. Bearings are the most critical moving part of the fan, therefore special care is required when mounting them on the unit and maintaining them.

Refer to the following chart and the manufacturer's instructions for grease types and intervals for various operating conditions. Never mix greases made with different bases. This will cause a breakdown of the grease and possible failure of the bearing.

Recommended Bearing Lubrication Schedule Relubrication Schedule in Months*								
Fan RPM	Bearing Bore (inches)							
	1/2 - 1	1 1/8 - 1 1/2	1 5/8 - 1 7/8	1 15/16 - 2 1/16	2 7/16 - 3	3 3/16 - 3 1/2	3 15/16 - 4 1/2	4 15/16 - 5 1/2
To 250	12	12	12	12	12	12	10	8
500	12	12	11	10	8	7	5	4
750	12	9	8	7	6	4	3	2
1000	12	7	6	5	4	3	2	1
1250	12	6	5	4	3	2	1	.5
1500	12	5	4	3	2	1	.75	
2000	12	3	3	2	1	.5	.25	
2500	12	2	2	1	.5	.25		
3000	12	2	1	.5	.25			
3500	12	1	.5	.25				
4000	12	.5	.25					
5000	12	.25						
Number of shots**	4	8	8	10	16	25	41	57

* Lubrication interval is based on 12 hour day operation and maximum 160°F housing temperature. For 24 hour per day operation, the interval should be cut in half.

** Lubricant should be added with the shaft rotating and until clean grease is seen purging from the bearing. The lubrication interval may be modified based on the condition of the purged grease. If bearing is not visible to observe purged grease, lubricate with number of shots indicated for bore size.

- For conditions including high temperatures, moisture, dirt or excessive vibration, consult the factory for a specific lubrication interval for your application.
- Lubricant should be a high quality lithium complex grease conforming to NLGI Grade 2. Factory recommends Mobilux EP-2 or synthetic Mobilith SHC100.
- The use of synthetic lubricants will increase lubrication intervals by approximately three times.
- Storage periods of three months or longer require monthly rotation of the shaft and purging grease prior to storage and start-up.

Belt Drive Maintenance

V-belt drives must be checked on a regular basis for wear, tension, alignment and dirt accumulation. Premature or frequent belt failures can be caused by improper belt tension, (either too loose or too tight) or misaligned sheaves. Abnormally high belt tension or drive misalignment will cause excessive bearing loads and may result in failure of the fan and/or motor bearings. Conversely, loose belts will cause squealing on start-up, excessive belt flutter, slippage, and overheated sheaves. Either excessively loose or tight belts may cause fan vibration.

When replacing V-belts on multiple groove drives all belts should be changed to provide uniform drive loading. Use a set of matched belts whenever possible. Do not pry belts on or off the sheave. Loosen belt tension until belts can be removed by simply lifting the belts off the sheaves.

After replacing belts, insure that slack in each belt is on the same side of the drive. Belt dressing should never be used.

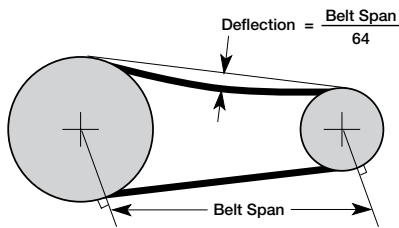

Do not install new belts on worn sheaves. If the sheaves have grooves worn in them, they must be replaced before new belts are installed.

The proper tension for operating a V-belt drive is the lowest tension at which the belts will not slip at peak load conditions. For more information about measuring belt tension, refer to Greenheck's Product Application Guide, FA/127-11, Measuring Belt Tension, found online at greenheck.com in the Resources section.

Check belt tension before start up and after the first 24 hours of operation. The belt tension should also be checked periodically thereafter.

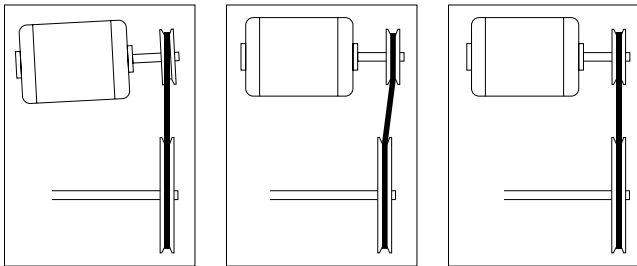

Improper sheave alignment

Proper sheave alignment

WARNING

Do not overtighten belts. Excessive belt tension can lead to premature belt and/or bearing failure.

Belt Adjustment

Belts on model IP are adjusted from the exterior of the fan. Covers should be opened or removed so the belt(s) can be inspected and checked for proper tension.

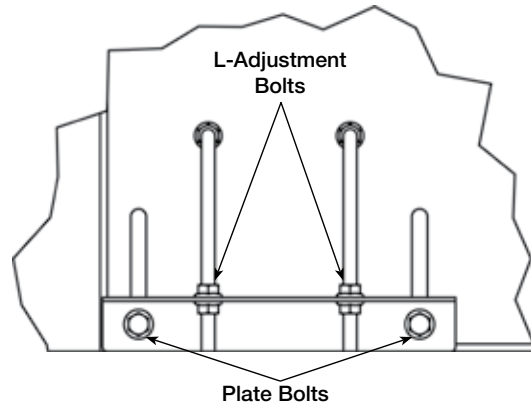

The tension of the belt(s) are adjusted by raising and lowering the motor plate. There are bolts on each side of the fan that must be used in order to adjust the belt(s). Each side has two plate bolts and two L-adjustment bolts.

1. Loosen, but DO NOT remove the two plate bolts on each side of the motor plate.
2. Loosen, then adjust the L-bolts to raise or lower the motor in order to tighten or loosen the belt(s) as needed. The nuts on the L-adjustment bolts should be adjusted evenly so the motor plate is raised or lowered as level as possible.
3. Tighten all the L-adjustment bolts and the plate bolts to lock motor in place after proper tension is reached.

NOTE

Loosen the plate bolts as minimal as possible to allow the plate to move, but so the plate has minimal movement when bolts are re-tightened.

WARNING

Be sure to raise or lower the motor plate as even as possible for proper belt engagement and to avoid jamming the plate.

Variable Frequency Drive Operation

WARNING

For operation with a Variable Frequency Drive (VFD), always check motor amps when adjusting the operating frequency. Motor may be sized for the original selected operating speed under 60 Hz. Bypassing the VFD or increasing the speed from this original selection, even if less than 60 Hz, may cause motor overload or failure. Consult factory with fan serial number before increasing the upper limiting frequency.

Always check the fan rpm when adjusting the operating frequency. Do not exceed maximum class fan rpm of the wheel as stated on the unit identification nameplate.

It is the responsibility of the installing body to perform coast-down tests and identify any resonant frequencies after the equipment is fully installed. These resonant frequencies are to be removed from the operating range of the fan by using the “skip frequency” function in the VFD programming. Failure to remove resonant frequencies from the operating range will decrease the operating life of the fan and void the warranty.

Field Coating Touch-Up Procedure for Scratched Areas

Standard coating and color is RAL7023 Concrete Grey. The procedure outlines the correct method for repairing minor scratches in the coating.

TOUCH-UP PAINT REPAIR KIT CONTENTS

- One pint of Kem Kromik® primer
 - including a technical data sheet
- One pint of industrial enamel
 - including a technical data sheet
- Four disposable foam brushes
- One sheet sandpaper
- Repair procedure details

1. Scuff affected area to be repaired using medium sandpaper (provided) or medium Scotch Brite™ pad. Feather the edges.
2. Clean affected area to be touched up using an alkaline based cleaner and rinse.
3. Apply Kem Kromik® primer using 1 inch foam brush (provided). Follow technical data sheet instructions.
4. Allow primer to dry a minimum of 2-1/2 hours before top coating.
5. Apply topcoat with industrial enamel using 1 inch foam brush (provided). Follow technical data sheets instructions. Allow painted units to air-dry and cure before putting into service. See Technical Data sheets (included with kit) for detailed drying and cure schedules at different temperatures.

NOTE

While the manufacturer provides heavy-duty, quality products for marine environments, routine paint touch-ups may be required in coastal regions where salt or marine air could damage the coating. The severe environment will accelerate the damage from any scratches or chips and it is recommended that those be repaired immediately.

To order additional coating repair kits please reference part number HAZ2597 PNT FIELD REPAIR KIT, RAL7023 CONCRETE GREY. Please contact factory with your fan's serial number for colors other than our standard.

Parts List

Each fan bears a manufacturer's nameplate with model number and serial number embossed. This information will assist the local manufacturer's representative and the factory in providing service and replacement parts. Before taking any corrective action, make certain unit is not capable of operation during repairs.

CAUTION

A fan manufactured with an explosion resistant motor does not certify the entire unit to be explosion proof. Refer to UL Listing Mark for the fans approved usage.

Industrial Process

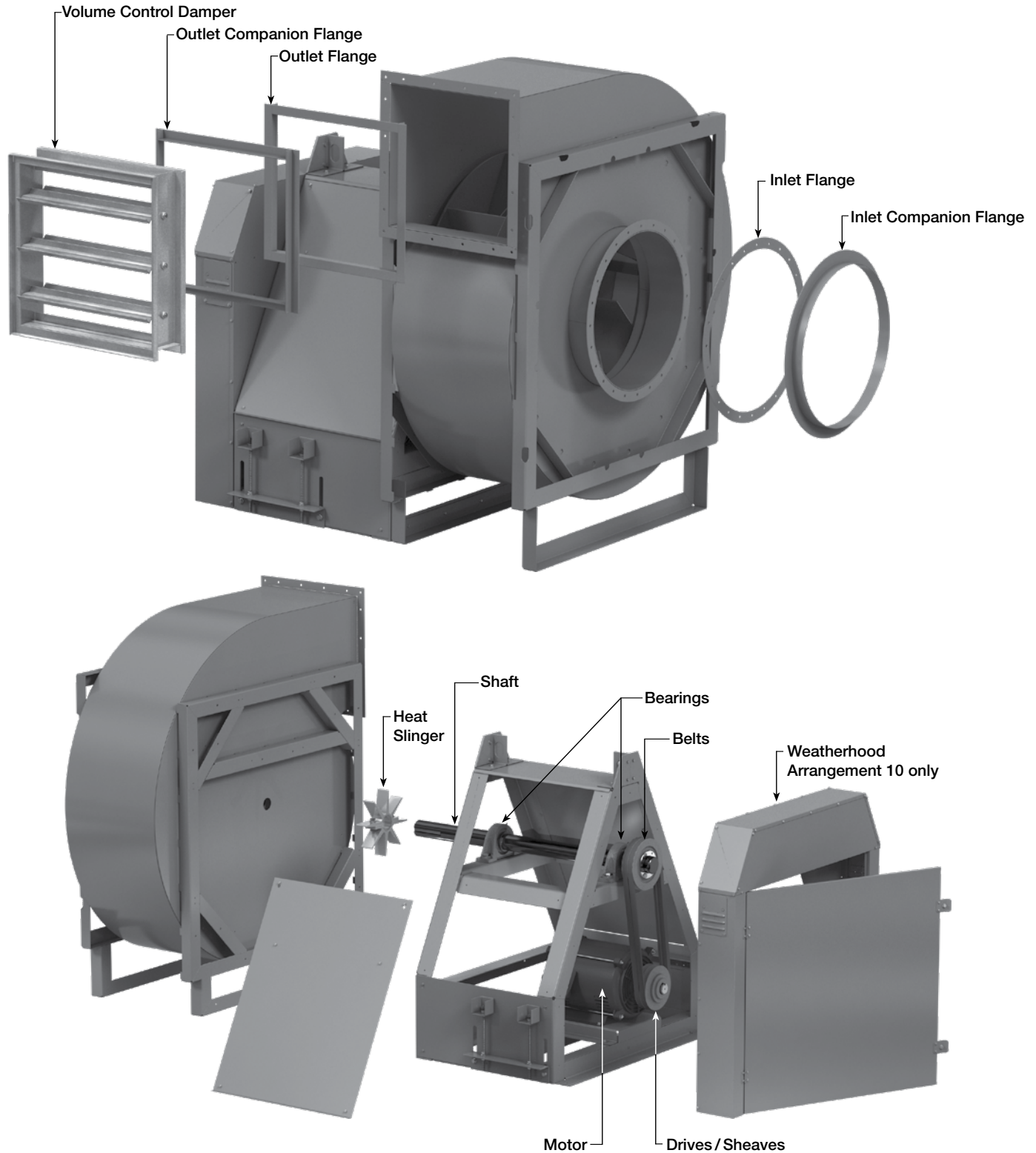

Troubleshooting

WARNING

Before taking any corrective action, make certain unit is not capable of operation during repairs.

Problem	Cause	Corrective Action
Excessive Noise	Wheel rubbing (inlet)	Adjust wheel and/or inlet cone. Tighten wheel hub or bearing collars on shaft.
	V-belt drive	Tighten Sheaves on motor/fan shaft. Adjust belt tension. Align sheaves properly (see V-Belt Drives section). Replace worn belts or sheaves.
	Bearings	Replace defective bearing(s). Lubricate bearings. Tighten collars and fasteners.
	Wheel unbalance	Clean all dirt off wheel. Check wheel balance, rebalance in place if necessary.
Low CFM	Fan	Check wheel for correct rotation. Increase fan speed.*
	Duct system	See page 3.
High CFM	Fan	Decrease fan speed.
	Duct system	Resize ductwork. Access door, filters, grilles not installed.
Static Pressure Wrong	Duct system has more or less restriction than anticipated	Change obstructions in system. Use correction factor to adjust for temperature/altitude. Resize ductwork. Clean filters/coils. Change fan speed.*
High Horsepower	Fan	Check rotation of wheel. Reduce fan speed.
	Duct system	Resize ductwork. Check proper operation of face and bypass dampers. Check filters and access doors.
Fan Doesn't Operate	Electrical supply	Check fuses/circuit breakers. Check for switches turned off or disconnected. Check for correct supply voltage.
	Drive	Check for broken belts. Tighten loose pulleys.
	Motor	Assure motor is correct horsepower and not tripping overload protector.
Overheated Shaft Bearing	Lubrication	Check for excessive or insufficient grease in the bearings.
	Mechanical	Replace damaged bearing. Relieve excessive belt tension. Align bearings. Check for bent shaft.
Excessive Vibration	Belts	Adjust tightness of belts. Replacement belts should be a matched set.
	System unbalance	Check alignment of shaft, motor and pulleys. Adjustable pitch pulleys with motors over 15 hp are especially prone to unbalance. Check wheel balance, rebalance if necessary.

*Always check motor amps and compare to nameplate rating. Excessive fan speed may overload the motor and result in motor failure. Do not exceed the maximum cataloged RPM of the fan.

NOTE: Always provide the unit model and serial numbers when requesting parts or service information.

Maintenance Log

Date _____ Time _____ AM/PM

Notes: _____

Date _____ Time _____ AM/PM

Notes: _____

Date _____ Time _____ AM/PM

Notes: _____

Date _____ Time _____ AM/PM

Notes: _____

Date _____ Time _____ AM/PM

Notes: _____

Date _____ Time _____ AM/PM

Notes: _____

Date _____ Time _____ AM/PM

Notes: _____

Date _____ Time _____ AM/PM

Notes: _____

Our Commitment

As a result of our commitment to continuous improvement, Greenheck reserves the right to change specifications without notice.

Product warranties can be found online at Greenheck.com, either on the specific product page or in the literature section of the website at Greenheck.com/Resources/Library/Literature.

Greenheck's Industrial Process Fans catalog provides additional information describing the equipment, fan performance, available accessories, and specification data.

AMCA Publication 410-96, Safety Practices for Users and Installers of Industrial and Commercial Fans, provides additional safety information. This publication can be obtained from AMCA International, Inc. at www.amca.org.

