

Installation Instructions for Belimo Actuators Direct Drive Series (AMB, FSLF, LMB, NMB, TFB)

These instructions apply to the external field installation of Belimo actuators on Greenheck control dampers.

These models are direct drive actuators that rotate to their energized position when power is applied, and spring return to their fail position when power is disconnected.

Model	Volts	Running	Holding
AMB24-3	24	2.5W	2.5W
AMB24-SR	24		
FSLF24-S	24	5VA	3.5VA
FSLF120 (-S)	120	18VA	6.5VA
FSLF230-S	230	17VA	6VA
LF120 (-S)	120	5.5W	3.5W
LF24 (-S)	24	5W	2.5W
LF24-SR (-S)	24	2.5W	1W
LMB24-3 (-S)	24	1.5W	1.5W
LMB24-SR	24		
NMB24	24	2W	2W
NMB24-SR	24	2.5W	2.5W
TFB24 (-S)	24	2W	1.3W
TF120 (-S)	120	2.5W	1.3W
TFB24-MFT (-S)	24	2.5W	1W
TF24-SR (-S)	24	2W	1W

Item	Part No.	Qty	Description
1	723092	1	Anti-rotation bracket
2	815027	1	Standoff bracket
3	415455	8	1/4 - 20 spinlock nut
4	417279	1	Mounting stud
5	415934	1	Keps hex nut zp
6	415264	8	1/4 - 20 x 1/2 TEK screw
7	-	1	Actuator

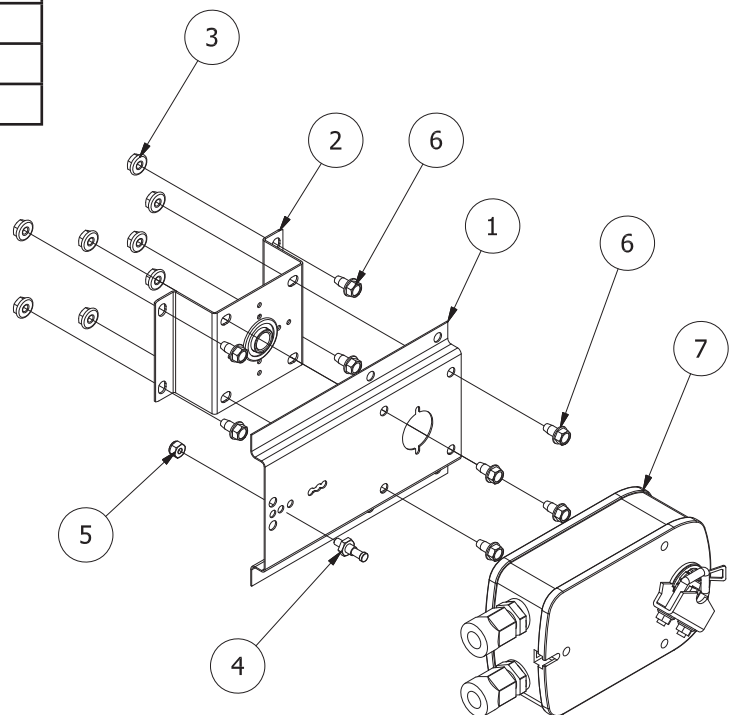

Instructions for Galvanized Steel Kit

1. Determine actuator fail position and change actuator clamp location if necessary.
2. Lock the actuator clamp in place using the retaining clamp.

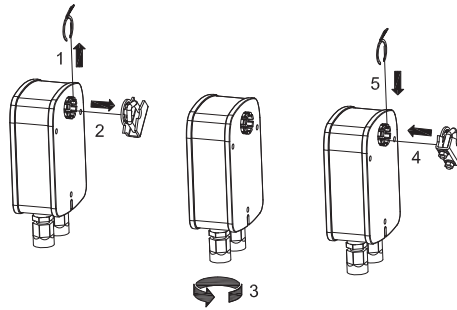

3. Remove the bearing from the stand-off bracket (jackshaft only).
4. Install stand-off bracket. Mark and drill $\frac{9}{32}$ in. holes (extension pin only).

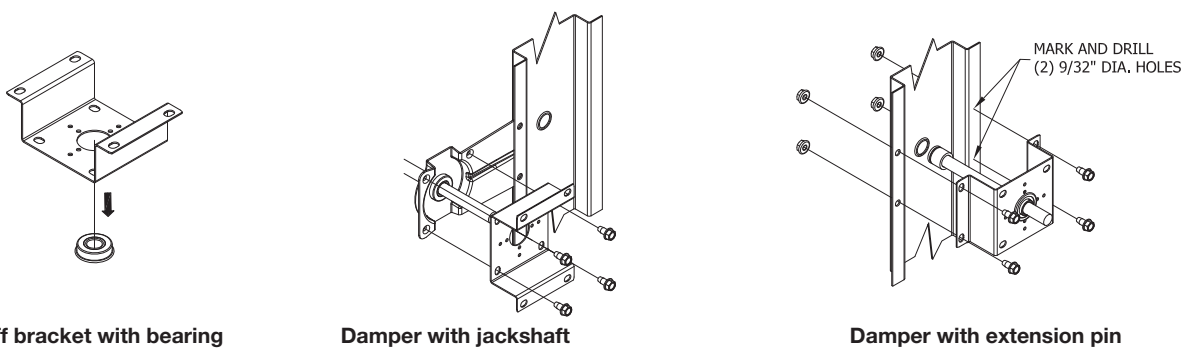

5. Install anti-rotation bracket and actuator. Anti-rotation bracket may be attached (a) perpendicular up, (b) perpendicular down, or (c) parallel from duct (shown).

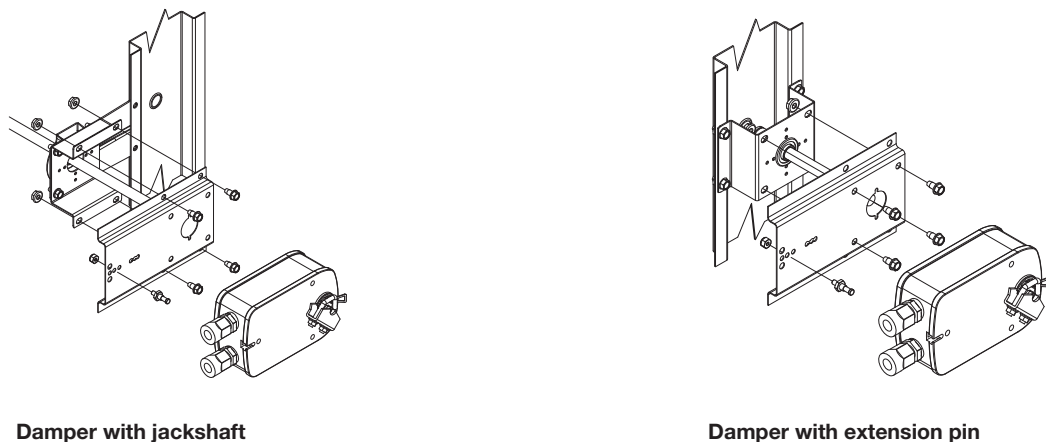

6. Rotate damper blades to desired fail position (open) or (closed, ensure blade seals are compressed). Tighten 10 mm hex screw to allow 95 degrees of actuator rotation.
7. Wiring should be per an approved project or job wiring diagram and must comply with all applicable wiring codes.
8. Apply power to the actuator. Damper blades should fully open or close and return to the fail position when power is disconnected.

316 Stainless Steel Kit

Item	Part No.	Qty	Description
1	687784	1	Standoff bracket 316SS
2	689990	1	Anti-rotation bracket 316SS
3	687405	1	Standoff bracket 316SS
4	415868	8	¼ - 20 x ½ TEK screw 316SS
5	463888	1	Mounting stud 316SS
6	415702	1	#10-32 hex nut 316SS
7	416204	1	1/4 lock washer SS
8	417305	8	¼ - 20 spinlock nut 316SS
9	-	1	Actuator

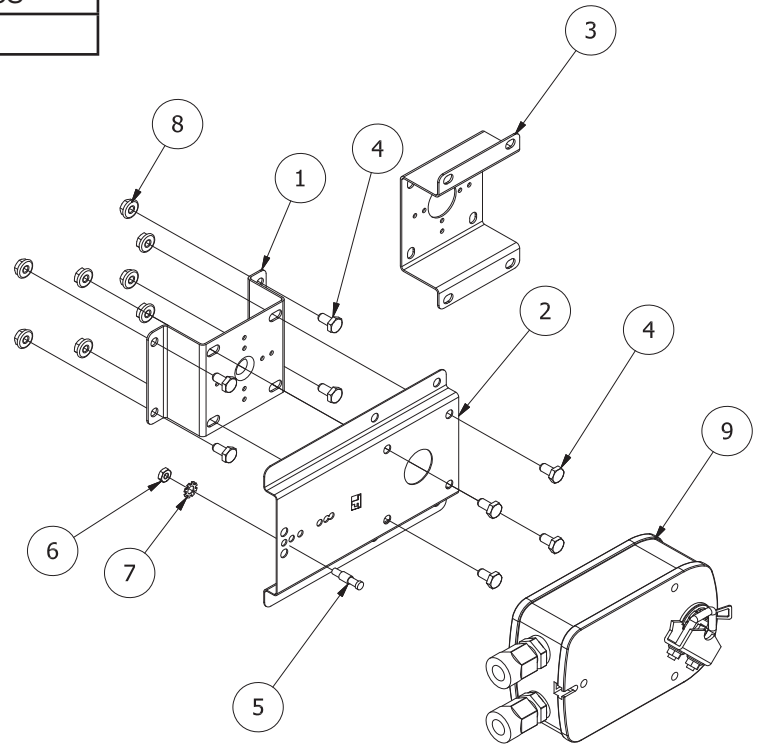

Instructions for 316SS Kit

1. Determine actuator fail position and change actuator clamp location if necessary.
2. Lock the actuator clamp in place using the retaining clamp.

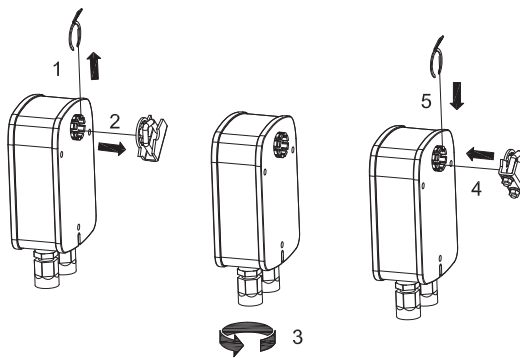

3. Install stand-off bracket. Mark and drill 9/32 in. holes (extension pin only).

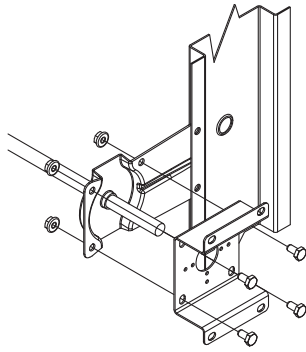

Damper with jackshaft

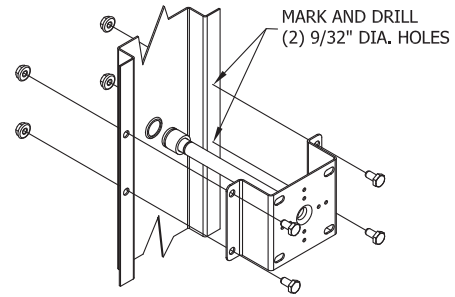

Damper with extension pin

4. Install anti-rotation bracket and actuator. Anti-rotation bracket may be attached (a) perpendicular up, (b) perpendicular down, or (c) parallel from duct (shown).

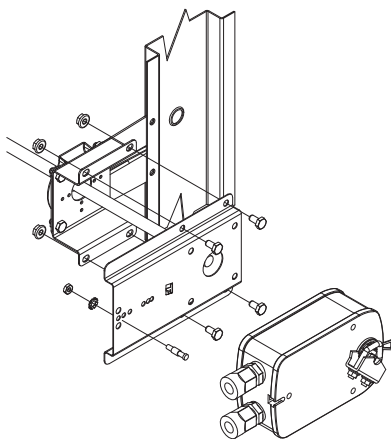

Damper with jackshaft

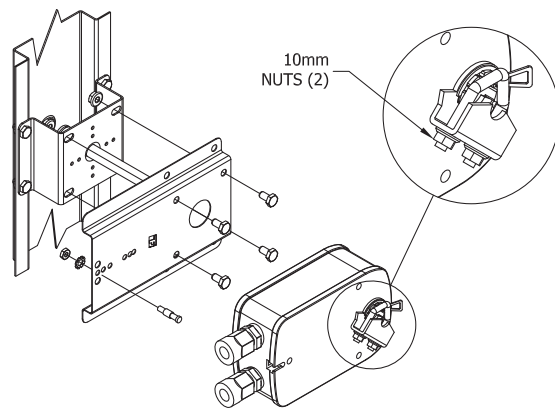

Damper with extension pin

5. Rotate damper blades to desired fail position (open) or (closed, ensure blade seals are compressed). Tighten 10 mm hex screw to allow 95 degrees of actuator rotation.
6. Wiring should be per an approved project or job wiring diagram and must comply with all applicable wiring codes.
7. Apply power to the actuator. Damper blades should fully open or close and return to the fail position when power is disconnected.

Our Commitment

As a result of our commitment to continuous improvement, Greenheck reserves the right to change specifications without notice.

Product warranties can be found online at Greenheck.com, either on the specific product page or in the literature section of the website at Greenheck.com/Resources/Library/Literature.

