

### Installation, Operation and Maintenance Manual

Please read and save these instructions for future reference. Read carefully before attempting to assemble, install, operate or maintain the product described. Protect yourself and others by observing all safety information. Failure to comply with these instructions will result in voiding of the product warranty and may result in personal injury and/or property damage.

#### Installing an RRL/OCI on a Combination Fire Smoke Damper:

- 1) Use a hole saw to drill a 3<sup>5</sup>/<sub>8</sub> in. (92 mm) diameter hole in sleeve (**Page 2, Detail 2**). See chart on page 2 for location of hole.
- 2) Attach indicator bracket to blade. For an airfoil blade dampers, use existing holes in blade (**Detail 1-A**). For a 3V blade damper, drill two 0.166 in. (4 mm) holes (**Detail 1-B**). Fasten bracket to blade with #10 x 1/2 in. (13 mm) self-drilling screws (or equivalent).
- 3) Fit indicator link into blade bracket (**Detail 1-C**).
- 4) Insert RRL/OCI unit through hole in sleeve (round end inside).
- 5) Place 4 in. x 4 in. J-box over the flange of the RRL/OCI unit and align holes.
- 6) Mount control box to sleeve/sideplate with #10-16 x 3/4 in. (19 mm) self-drilling screw or equivalent (**Detail 1-D**).
- 7) Place one push nut on the switch wire. Place indicator link on switch wire and secure with a second push nut (**Detail 1-D**).
- 8) Complete wiring and install J-box cover.

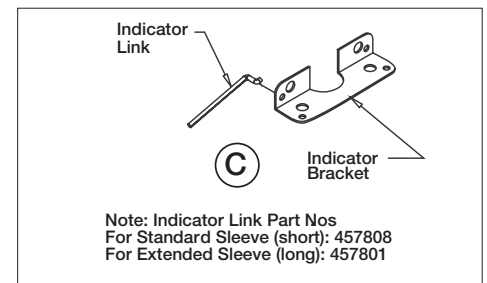
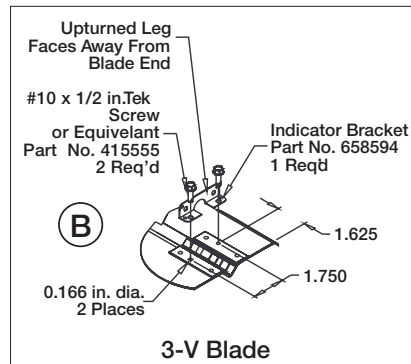
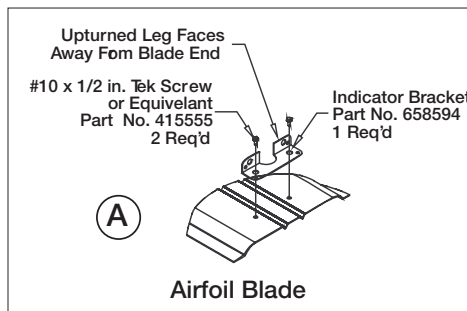

#### RRL/OCI - Exploded View

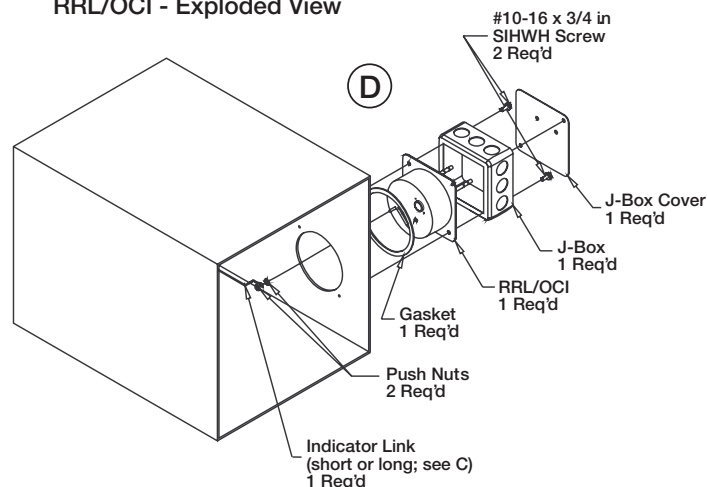

#### Detail 1

**Note:** Operator mounted upside-down on steel airfoil units from 10 in. to 17 in. (254 mm to 432 mm)

Nominal Section Height (in.)	3V Style (D)	Steel Airfoil Style (D)
6-7	2.625	2.625
8	3.125	3.125
9	3.625	3.625
10-11*	2.625	3.625
12-13*	2.625	4.125
14-15*	3.125	4.625
16*	3.625	5.125
17*	4.125	5.625
18	13.125	13.125
19	14.125	14.125
20	14.625	14.625
21	15.625	15.625
22	16.625	16.625
23	17.125	17.125
24	18.125	18.125
25	19.625	19.625
26	20.625	20.625
27, 39-41	21.625	21.625
28, 42	22.125	22.125
29, 43, 57	23.125	23.125
30, 44, 58	24.125	24.125
31, 45, 55-56, 59	25.125	25.125
32	26.625	26.625
33, 47	27.625	27.625
34, 46	28.625	28.625
35, 49	29.125	29.125
36, 48	30.625	30.625
37, 51	31.125	31.125
38, 50, 52	32.125	32.125
53	23.625	23.625
54	24.625	24.625
60	4.125	4.125

**Detail 2**

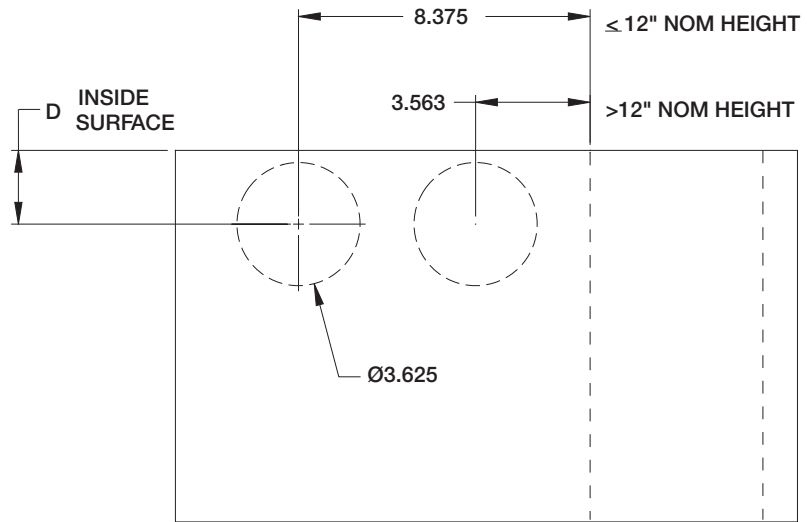

**Wiring Diagram**

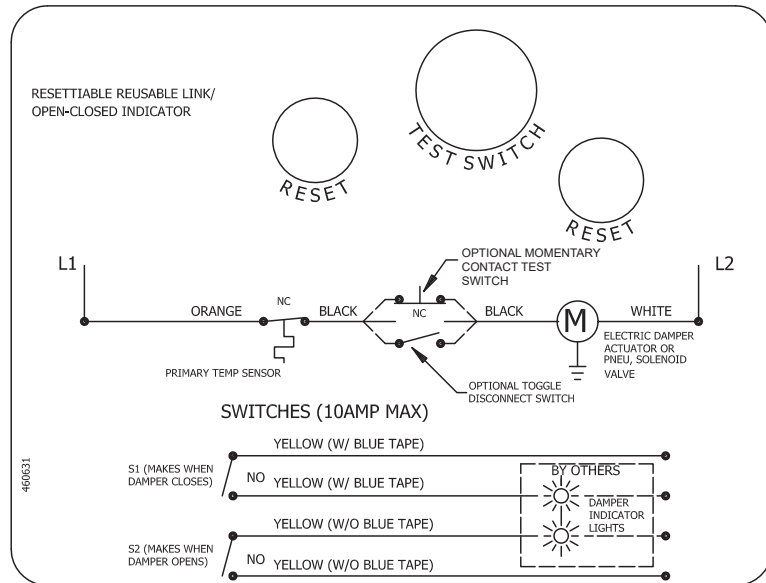

**Our Commitment**

*As a result of our commitment to continuous improvement, Greenheck reserves the right to change specifications without notice.*

Product warranties can be found online at [Greenheck.com](http://Greenheck.com), either on the specific product page or in the literature section of the website at [Greenheck.com/Resources/Library/Literature](http://Greenheck.com/Resources/Library/Literature).

