

## Assembly Instructions

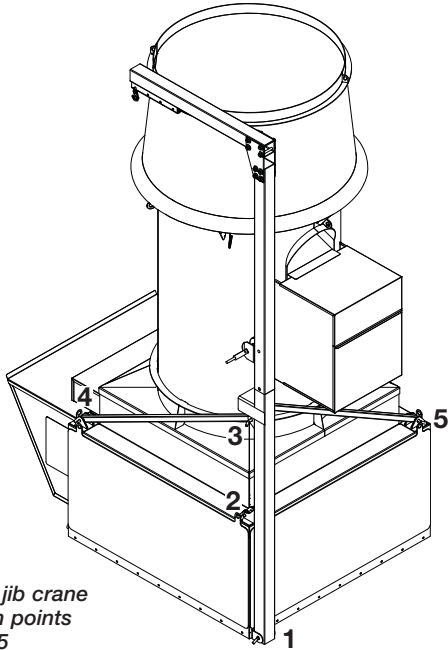

Reference jib crane connection points 1 through 5

### NOTE

If jib crane is being installed on a belt drive fan system, the location of the motor cover on each fan must be on the same side as the crane/post assembly. This will allow the jib crane to reach the motor as needed.

### NOTE

Belt drive model shown. Procedure is identical for direct drive models.

### NOTE

Multiple fan systems will have more than one set of connection sockets. Mount jib crane to socket set nearest motor to be replaced.

### NOTE

Observe all warning labels on Post Assembly and Jib Crane Boom parts.

**Step 1:** Slide pivot pad (B) into end of post (A).



Slide pivot pad into end of post



**Step 2:** With the crane post bracket facing up, insert the assembled post into connection point 1 on the plenum. Attach the jib crane assembly to plenum using the 1 x 6.75 inch hitch pin (D) to secure the post end of the jib crane to plenum. Lock hitch pin in place with cotter pin (G).

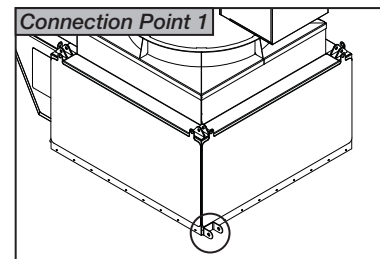

### PARTS LIST

**A**

POST ASSEMBLY  
QTY 1

**B**

PLASTIC  
PIVOT PAD

**C**

JIB CRANE BOOM  
QTY 1

**D**

HITCH PIN  
1-INCH x 6.75-INCH  
QTY 2

**E**

HITCH PIN  
1-INCH x 4.75-INCH  
QTY 4

**F**

SUPPORT TUBE  
QTY 2

**G**

COTTER PIN  
QTY 6

Connection Point 1

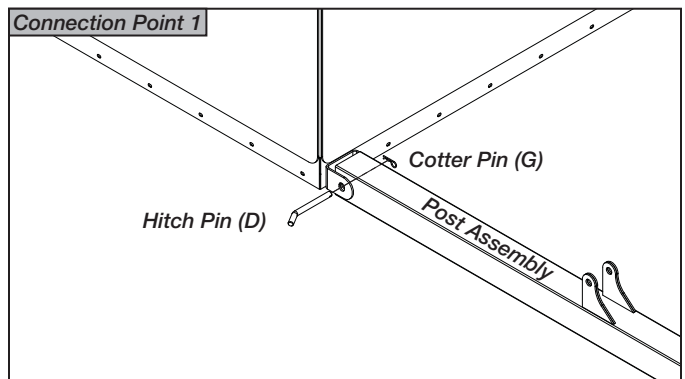

**Step 3:** Insert boom (C) over pivot pad inserted into post.

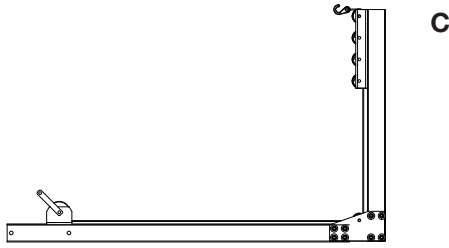

Insert boom over assembled post/pivot pad.

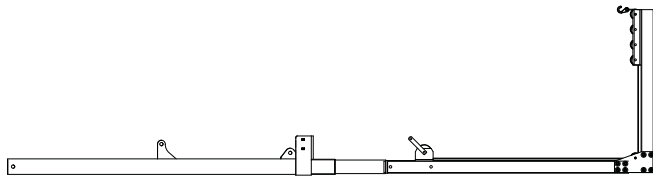

**Step 4:** Rotate jib crane boom straight up from the roof deck. Temporarily install one 1 x 4.75 inch hitch pin (E) into connection point 4 on the plenum. Lock hitch pin in place with cotter pin (G). Secure jib crane cable to now installed hitch pin located in plenum connection point 4 with crane hook.

**WARNING**

Do not attach cable to windband lifting lug or to access door lifting point on plenum.

**NOTE**

Cable on Vektor size 36 through 40 will require five feet additional strapping (size 44 and larger will require 15 feet) attached to the Crane Hook to raise the jib crane assembly into position.

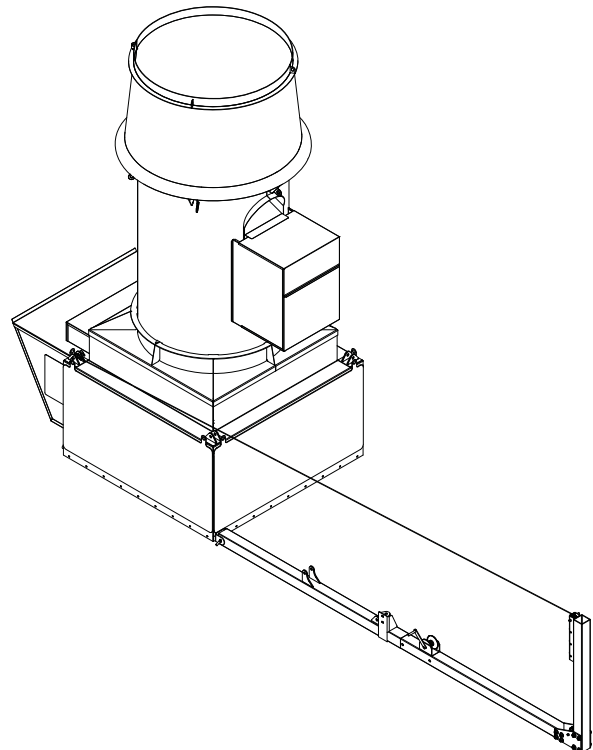
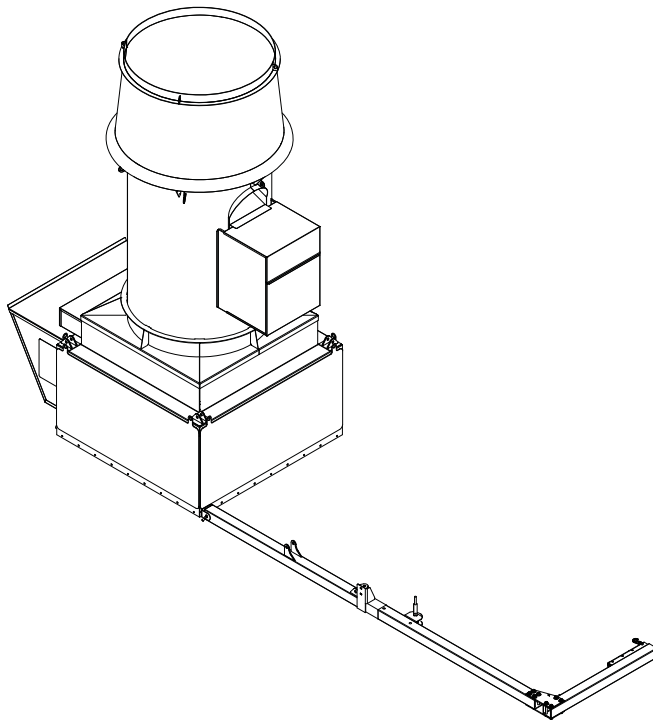
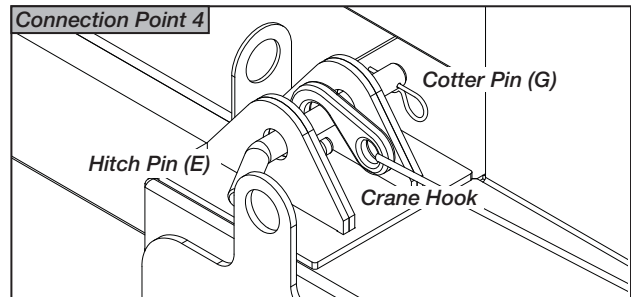

**Step 5:** Raise jib crane assembly by hand-lifting and using jib crane hand winch until fully erect.

**NOTE**

Hand winch equipped with self-activating automatic brake.

**CAUTION**

Do not stand under the jib crane as it is being raised or lowered. Slack in the wound cable could cause crane assembly to suddenly drop downward and cause serious injury or death.

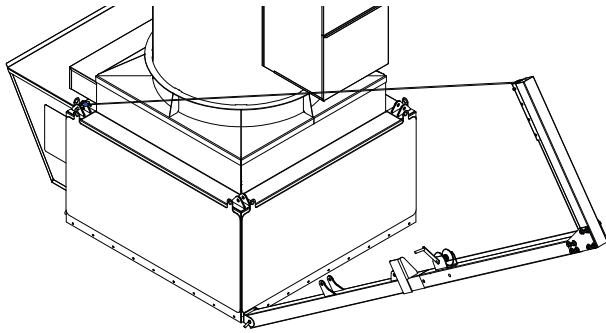

**Step 6:** Secure jib crane assembly to plenum at connection point 2 using one 1 x 6.75 inch hitch pin (D). Lock hitch pin in place with cotter pin (G). Make sure jib crane is firmly attached to plenum.

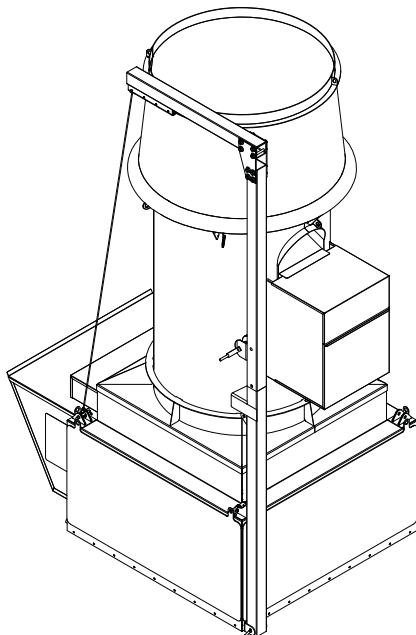
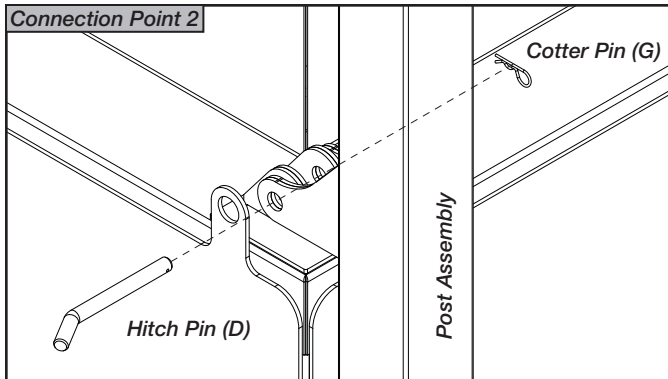

**Step 7:** At bracket connection point 3 and facing connection point 5, attach one support tube (F) at connection point 3 on jib crane using one 1 x 4.75 inch hitch pin (E). Lock hitch pin in place with cotter pin (G). Spread support tube out and attach the loose end to matching plenum connection point 5. Secure end with 1 x 4.75 inch hitch pin (E). Lock hitch pin in place with cotter pin (G).

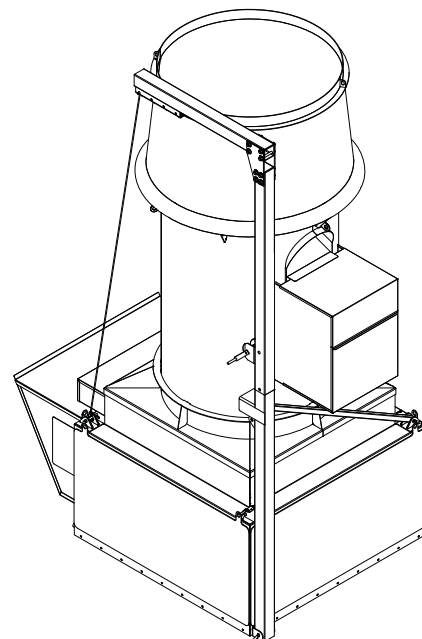
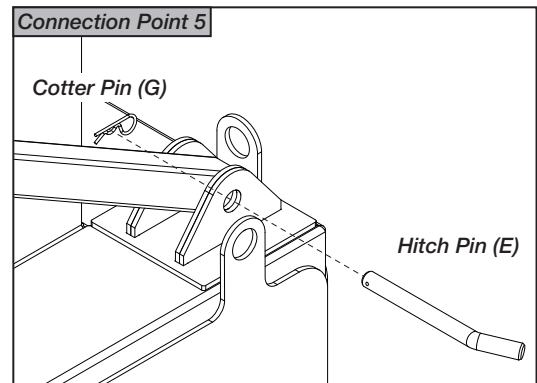
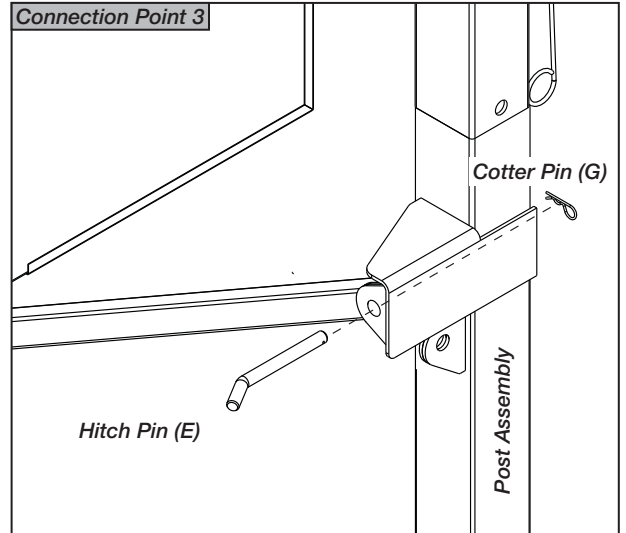

**Step 8:** Detach cable from hitch pin located at connection point 4 and remove hitch pin from connection point.

**NOTE**

It is recommended that moderate tension be kept on the cable while it is wound onto the spindle to prevent the cable from being tangled.

**Step 9:** Attach remaining support tube (F) to bracket located at connection point 3 on jib crane facing connection point 4. Use 1 x 4.75 inch hitch pin (E) to secure. Lock hitch pin in place with cotter pin (G). Spread support tube out and attach the end of one tube to the plenum connection point 4. Secure end with 1 x 4.75 inch hitch pin (E). Lock hitch pin in place with cotter pin (G).

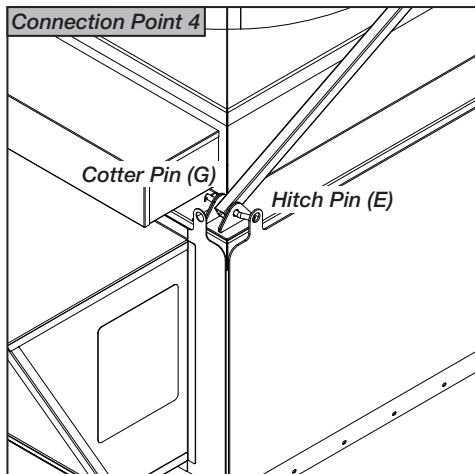
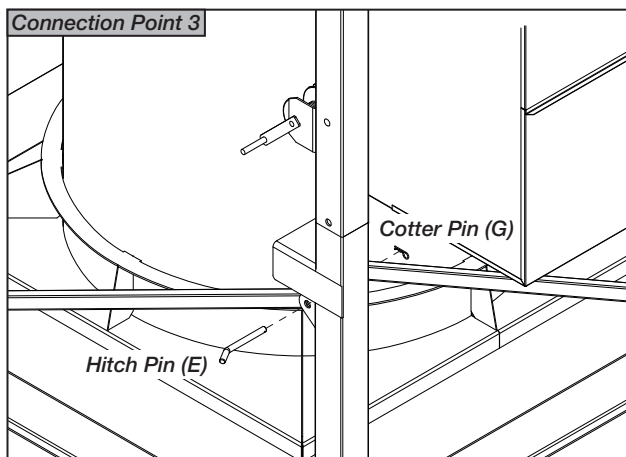

Jib crane assembly is now fully secured to the plenum. Refer to Vektor Installation, Operation and Maintenance Instruction for motor replacement procedure.

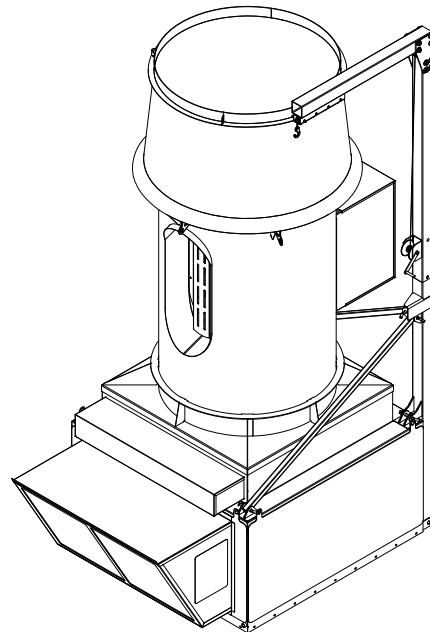

Disassembly of jib crane should be performed in reverse order of assembly instructions. Do not disassemble while motor is connected to jib crane hoist.

**NOTE**

Cable on Vektor sizes 44 and larger with roof curbs over 12 inches in height will require additional strapping attached to the Crane Hook to lower and raise the motor to the roof deck level. Reference Vektor-MD IOM for motor removal and installation procedure.

**CAUTION**

Do not stand under jib crane as it is being raised or lowered. Slack in the wound cable could cause the subassembly to suddenly drop downward and cause serious injury or death.