

Multiple Sections

Height > 96 1/2 ≤ 144 1/2

F2 HEAD DETAIL
(OPENING HEIGHT >96 1/2" & ≤144 1/2")

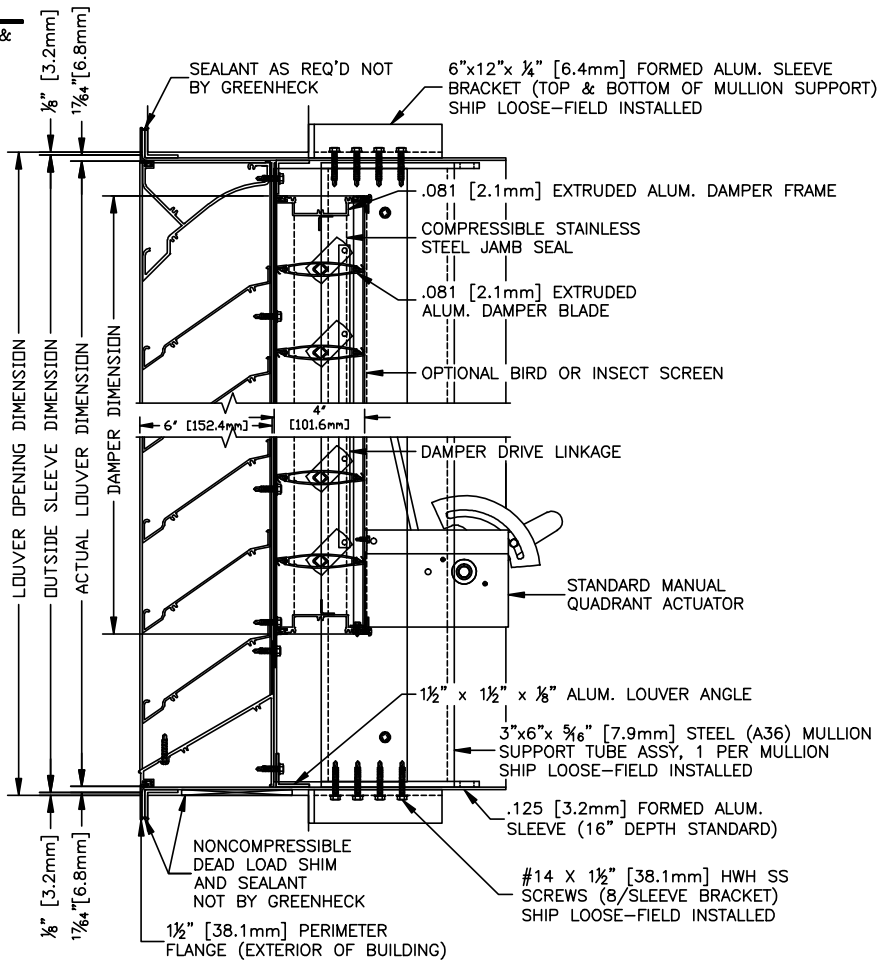

G2 SILL DETAIL
(OPENING HEIGHT >96 1/2" & ≤144 1/2")

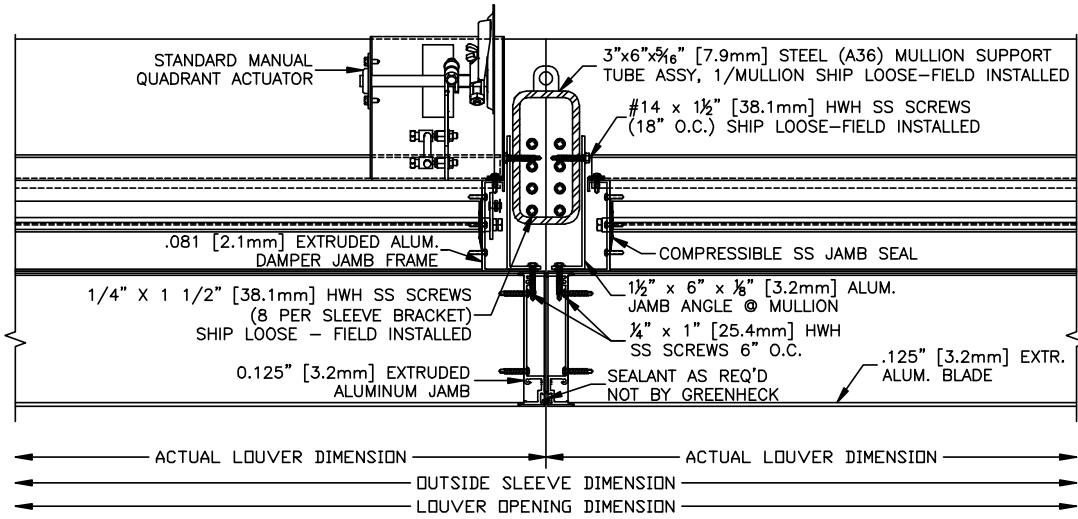

J1 MULLION DETAIL
(OPENING HEIGHT >96 1/2" & ≤144 1/2")

Single Section

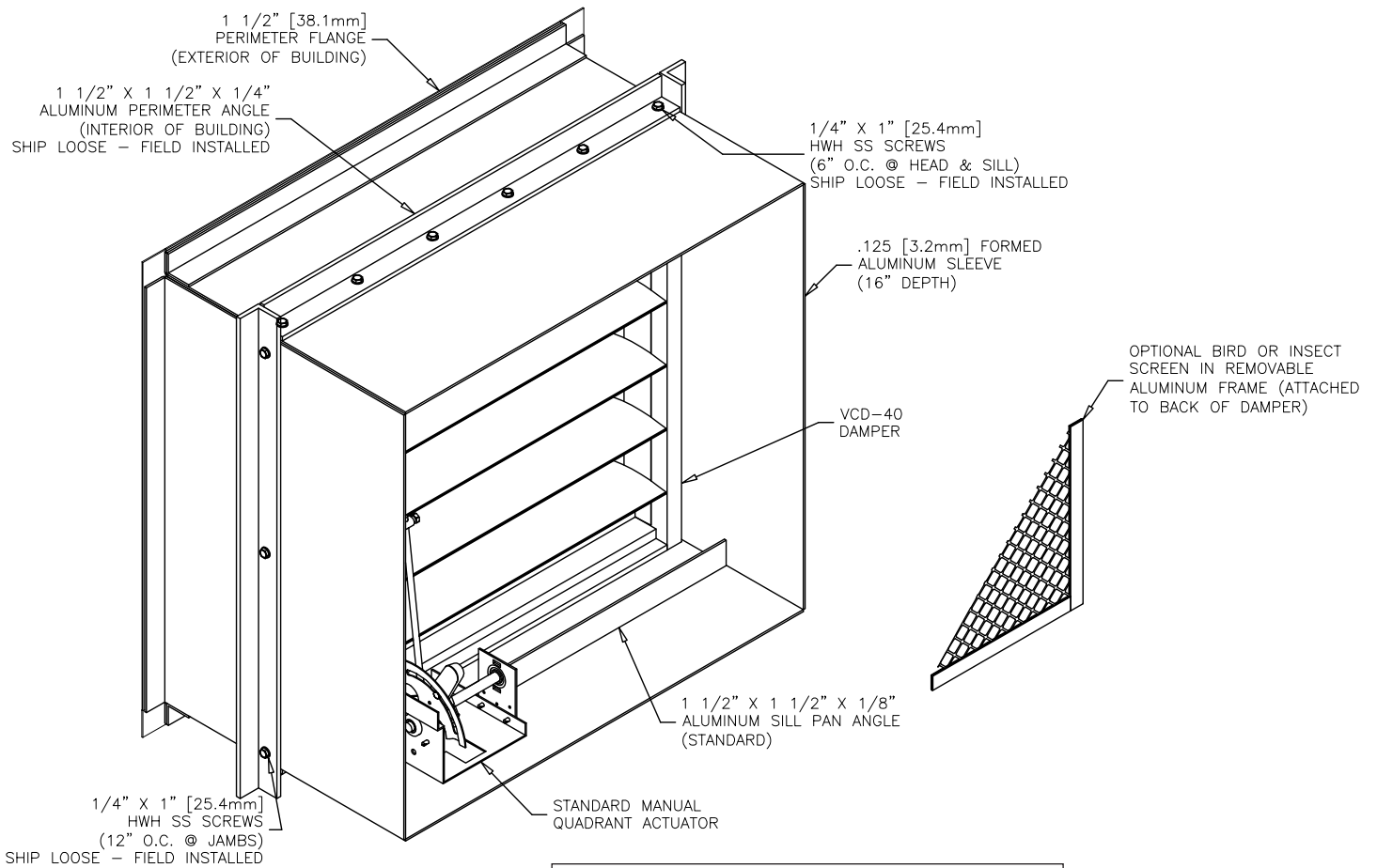

Structure Depth

- Min. structure depth 4 in.
- Max. structure depth 14.5 in.

Multiple Sections

Height ≤ 96 1/2

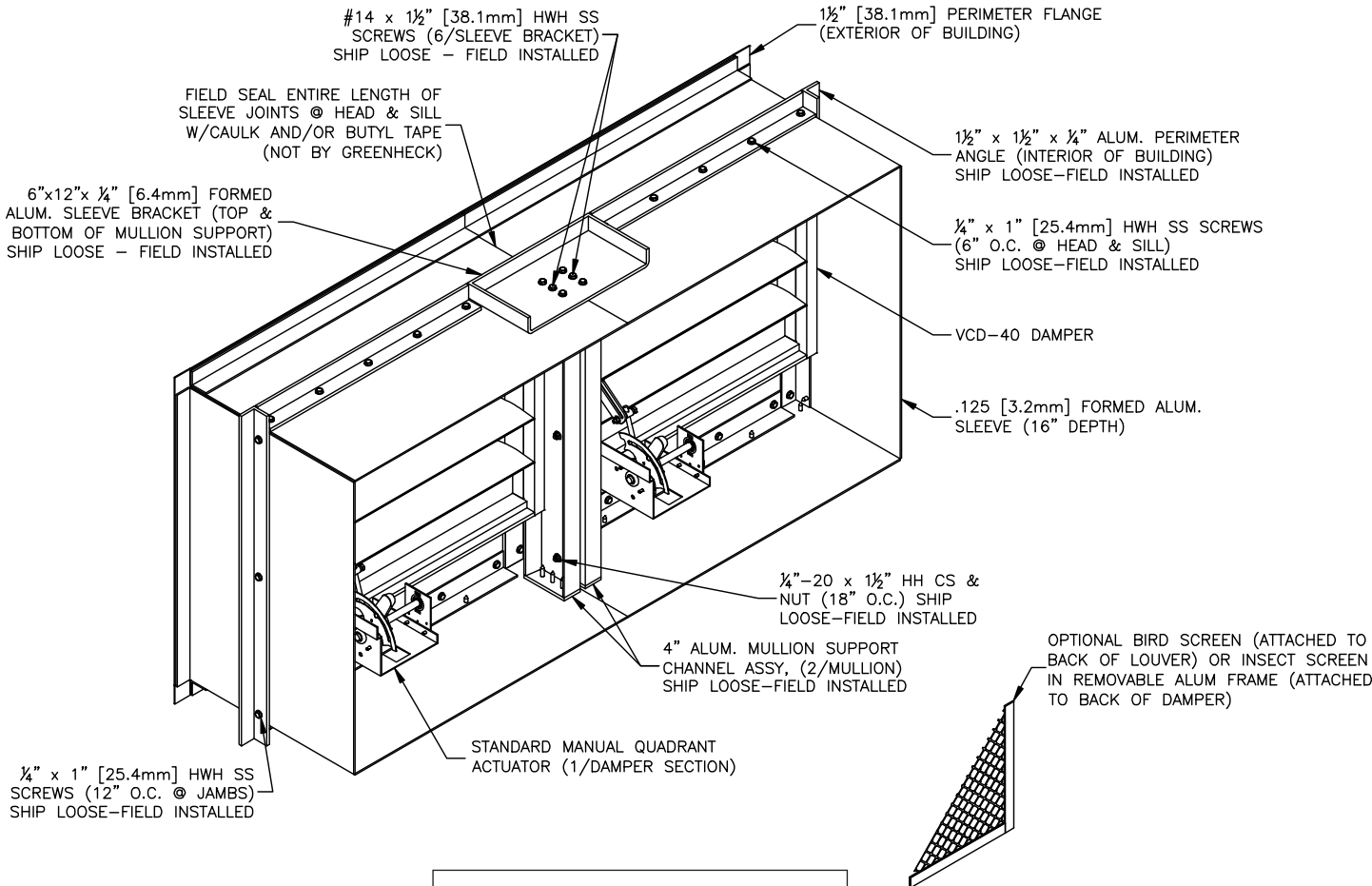

Structure Depth

- Min. structure depth 4 in.
- Max. structure depth 11.5 in.

Multiple Sections

Height > 96 1/2" ≤ 144 1/2"

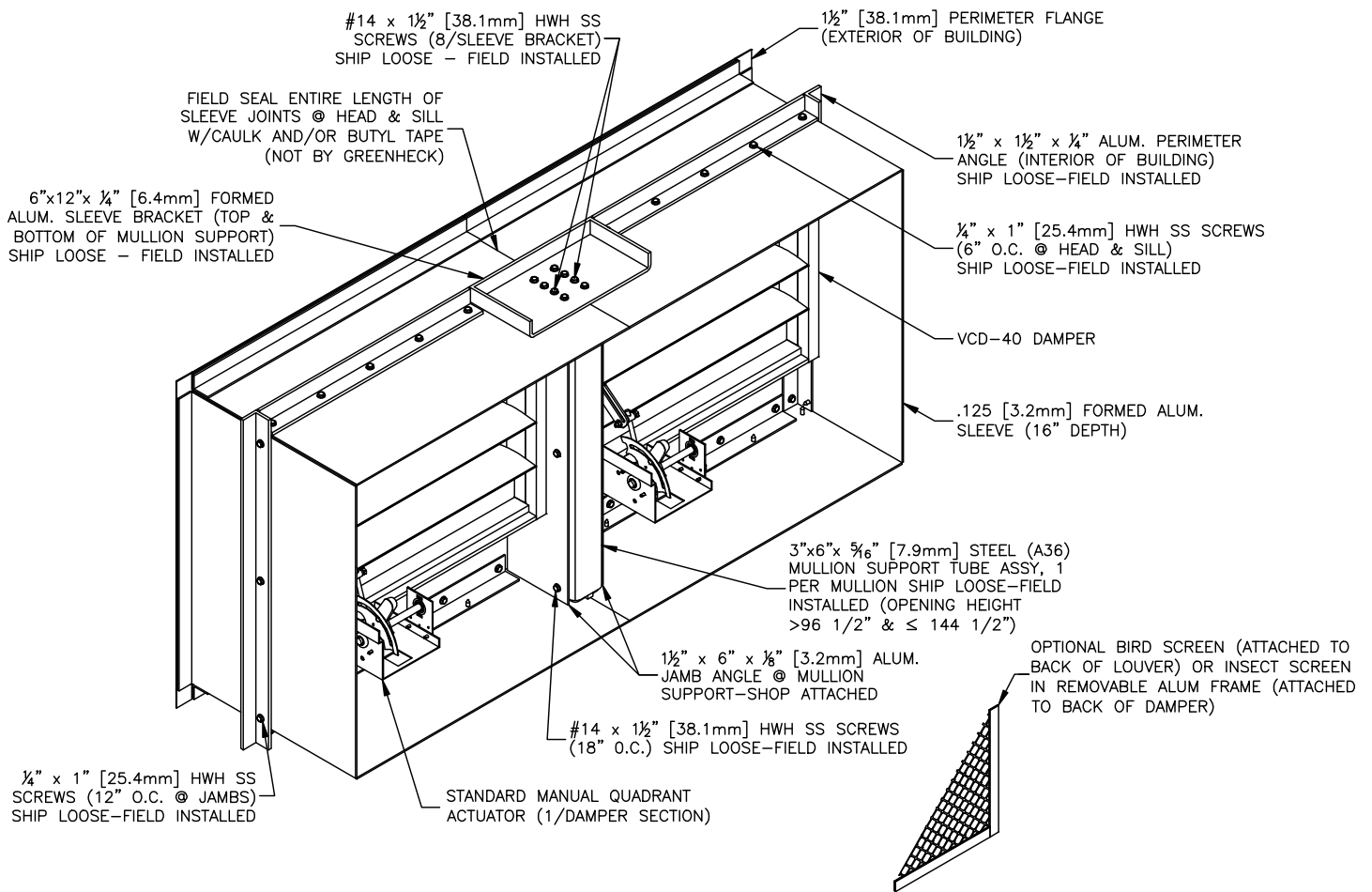

Structure Depth

- Min. structure depth 4 in.
- Max. structure depth 13.25 in.

Our Commitment

As a result of our commitment to continuous improvement, Greenheck reserves the right to change specifications without notice.

Product warranties can be found online at Greenheck.com, either on the specific product page or in the literature section of the website at Greenheck.com/Resources/Library/Literature.

