

Installation, Operation and Maintenance Manual

Please read and save these instructions for future reference. Read carefully before attempting to assemble, install, operate or maintain the product described. Protect yourself and others by observing all safety information. Failure to comply with these instructions will result in voiding of the product warranty and may result in personal injury and/or property damage.

Maximum Wind-load: 150 PSF

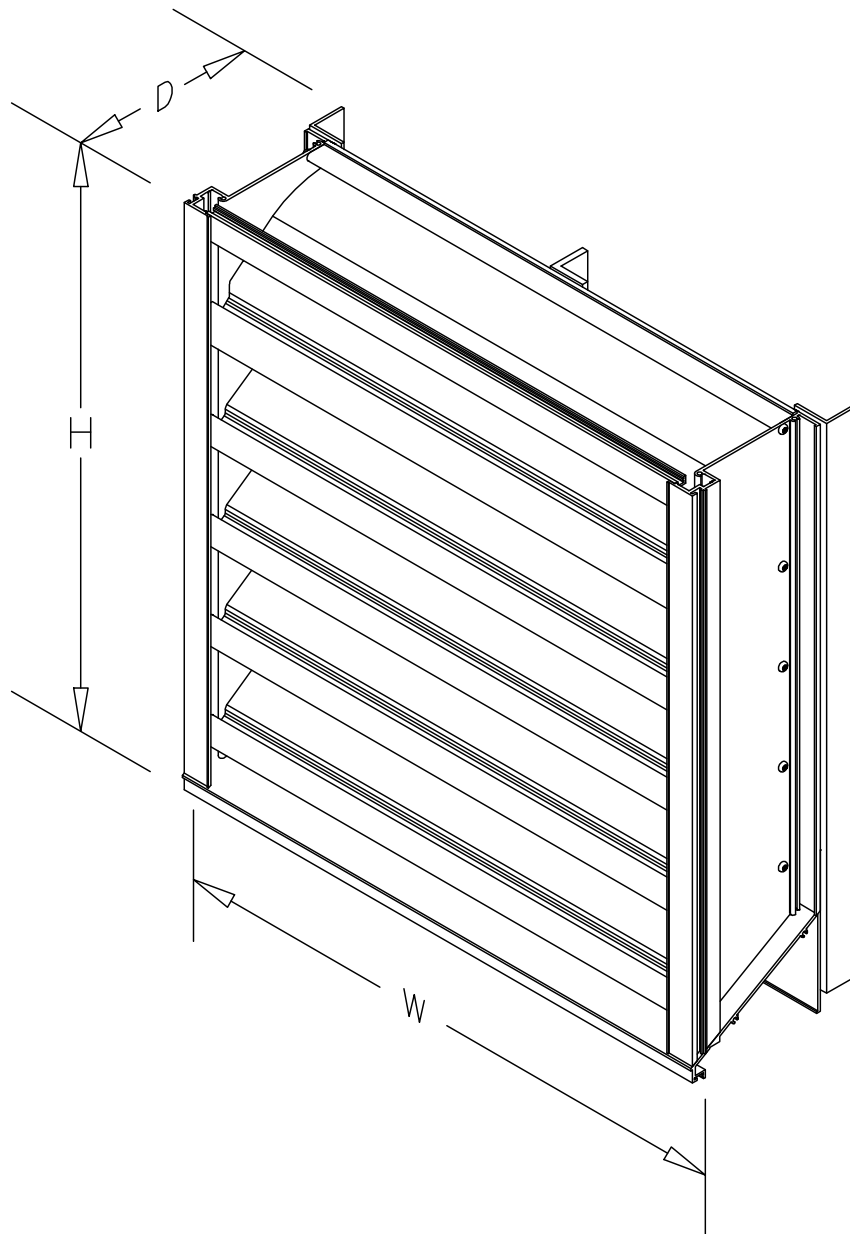

Maximum Size and Installation Information

Model ESD-635D is a Miami-Dade Qualified and Florida Product Approved louver and must be installed in accordance with the installation instructions shown herein. Model ESD-635D is qualified for installation within concrete/masonry, steel stud, structural steel or wood framed building conditions. Model ESD-635D is structurally calculated to withstand positive and negative wind-loads up to 150 PSF. The maximum single section rough opening width is 72.75 in. The maximum single section rough opening height is 144.50 in. While the maximum rough opening height is limited to 144.50 in., the rough opening width is limited to 1,000 in. as multiple sections may be installed side by side in accordance with installation instructions.

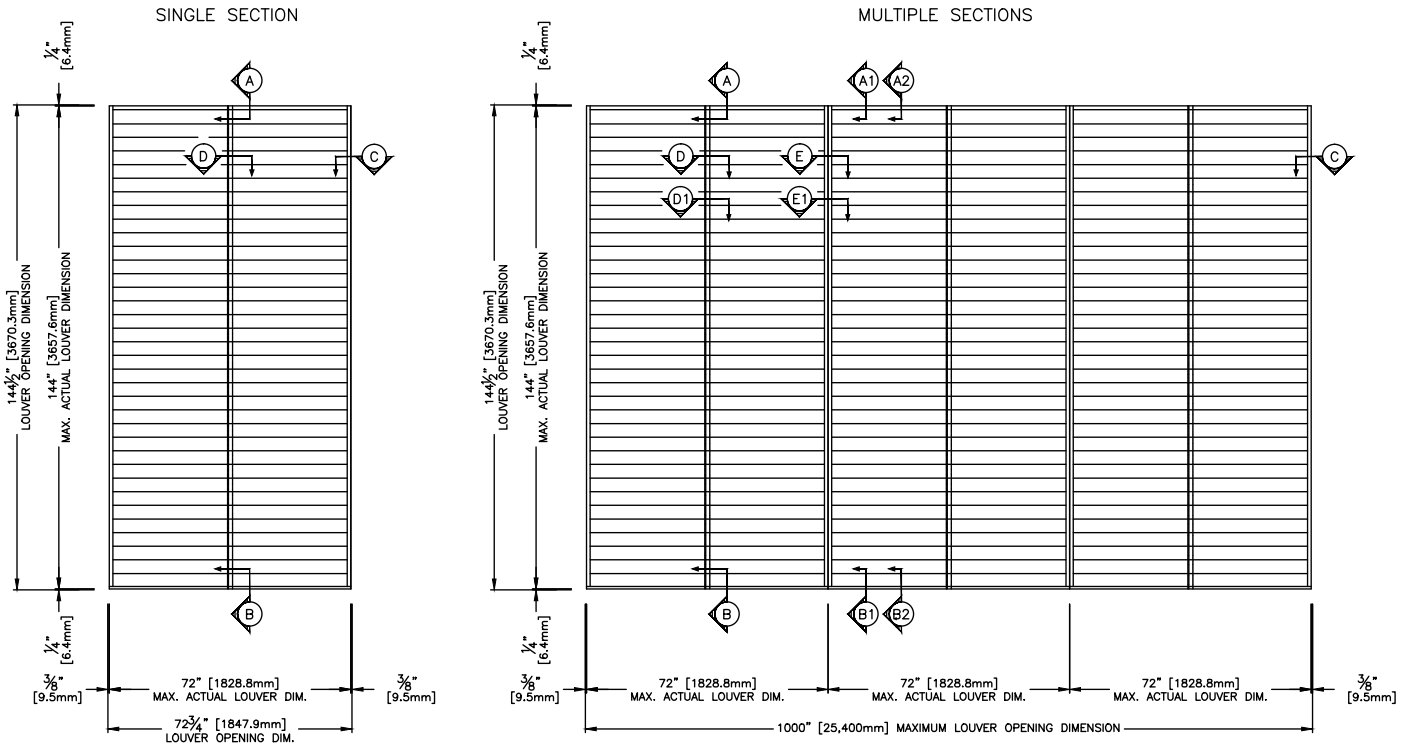

**Minimum Rough
Opening Size**
12 in. W x 12 in. H

**Maximum Single Section
Rough Opening Size**
72.75 in. W x 144.50 in. H

Building Condition/Substrate Limitations

- All metal stud substrate should be min. 10 Ga. FY= 36 KSI
- All structural steel substrate shall be min. 0.125 in. thick FY= 36 KSI
- All concrete substrate shall be min. 4000 PSI (2000 PSI allowed with SDR)
- Concrete masonry shall be ASTM C90, Type II, 2000 PSI, grout-filled

Single Section

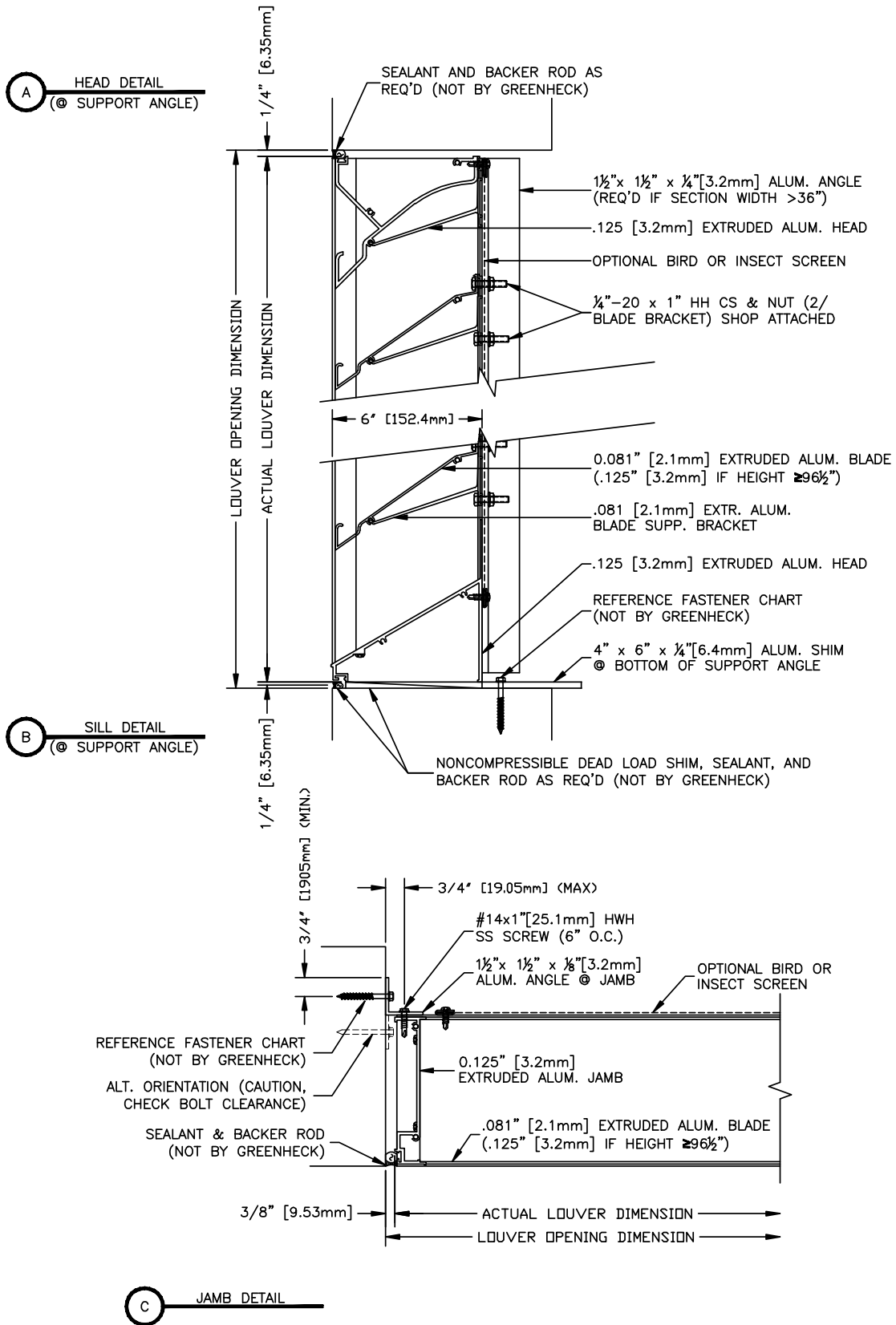

Multiple Sections

Height $\leq 96 \frac{1}{2}$

Reference page 5 for alternate head/sill detail.

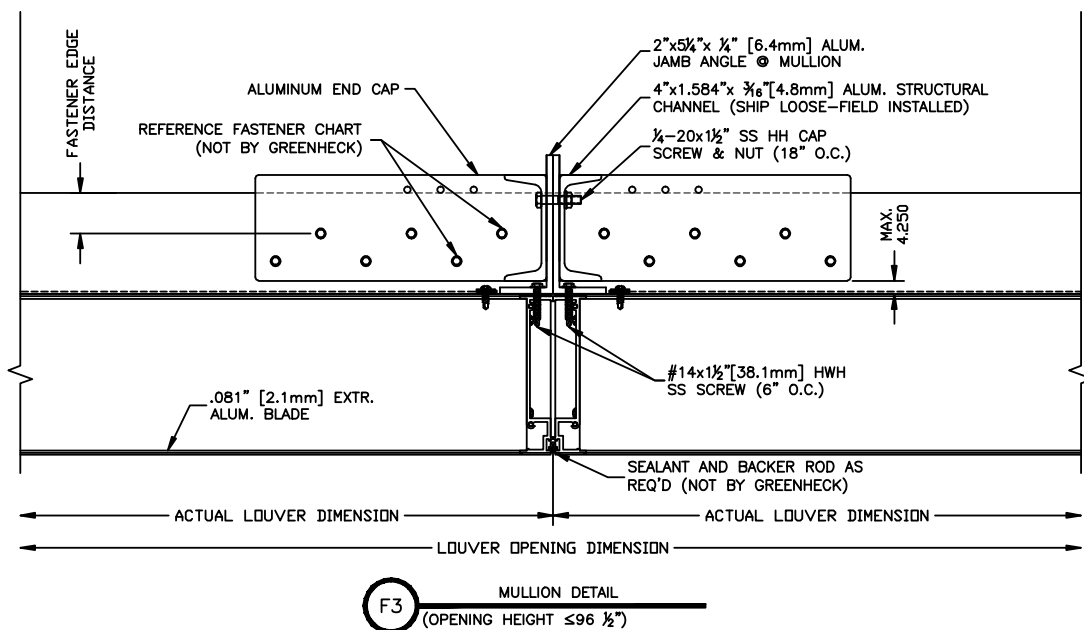
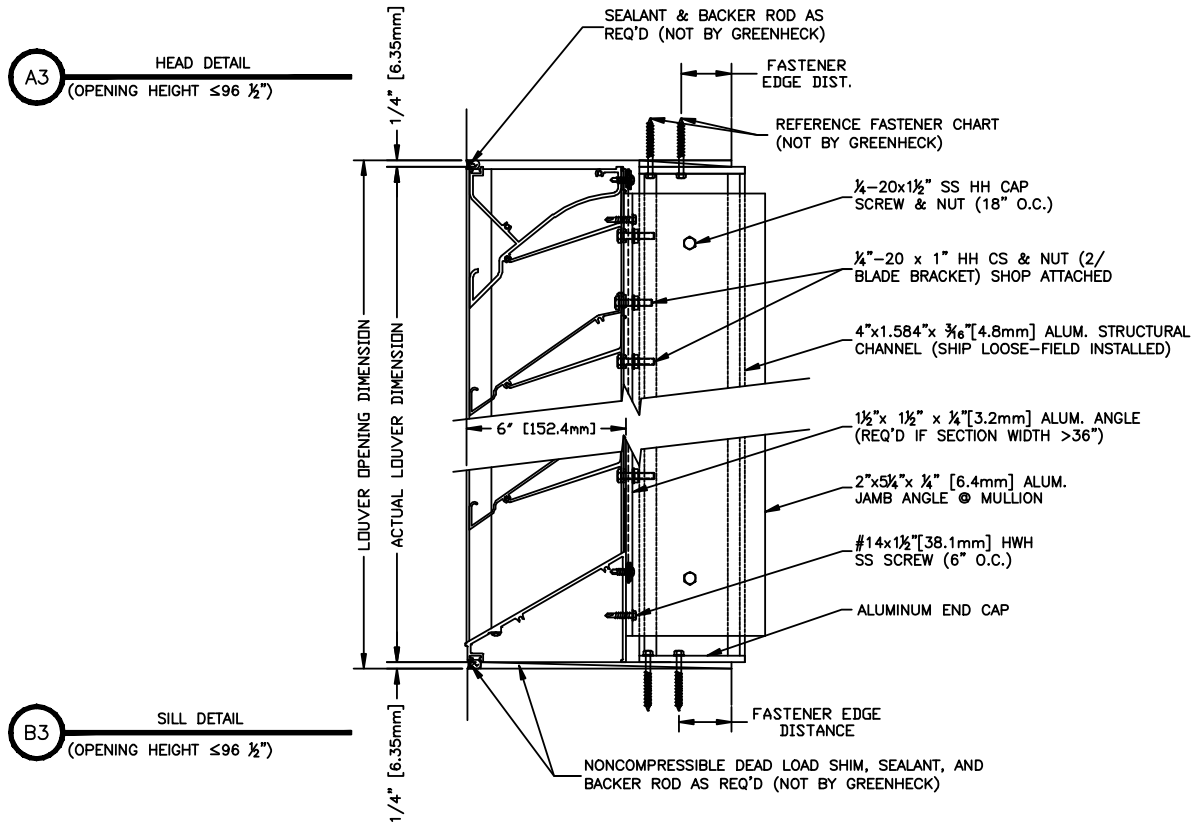

Multiple Sections

Height ≤ 96 1/2"

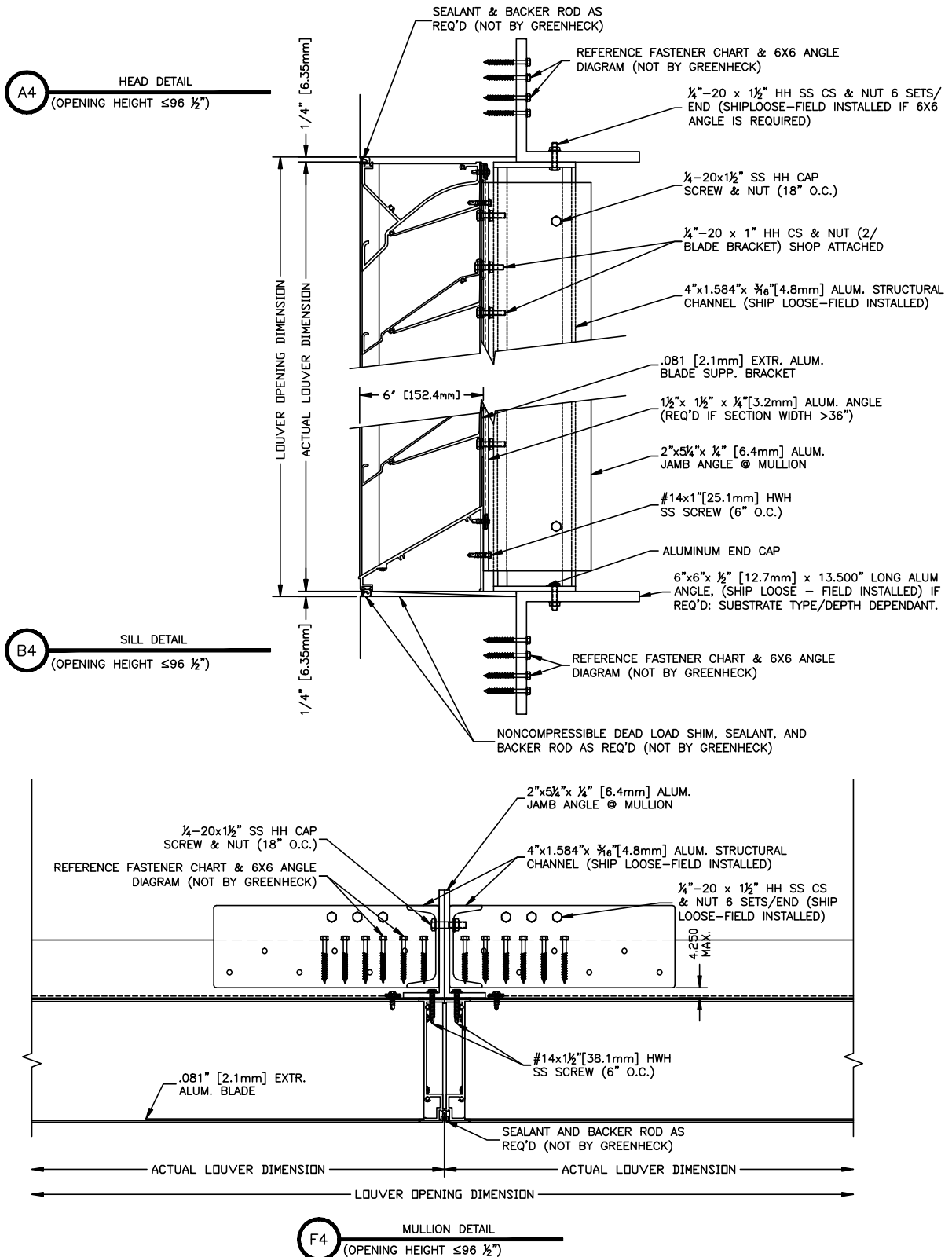

Multiple Sections

Height > 96 1/2" ≤ 144 1/2"

Reference page 7 for alternate head/sill detail.

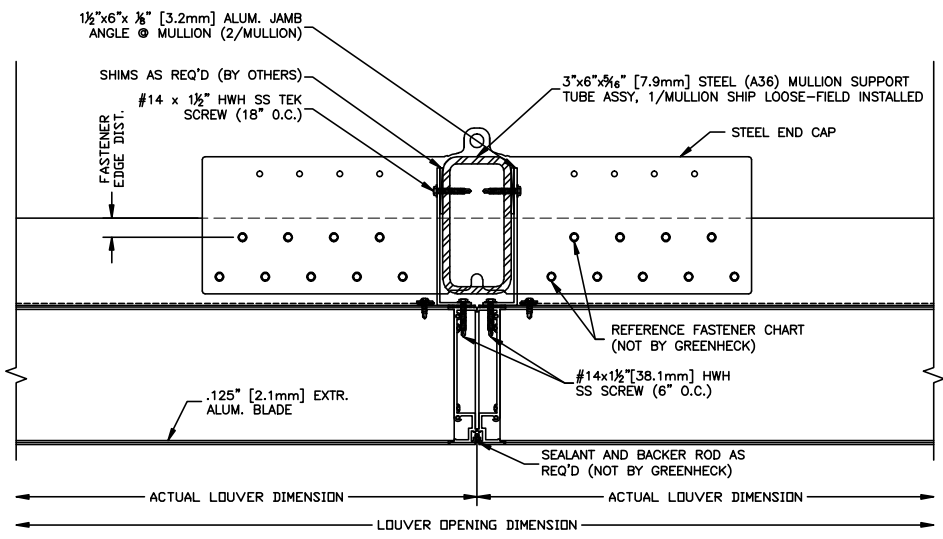
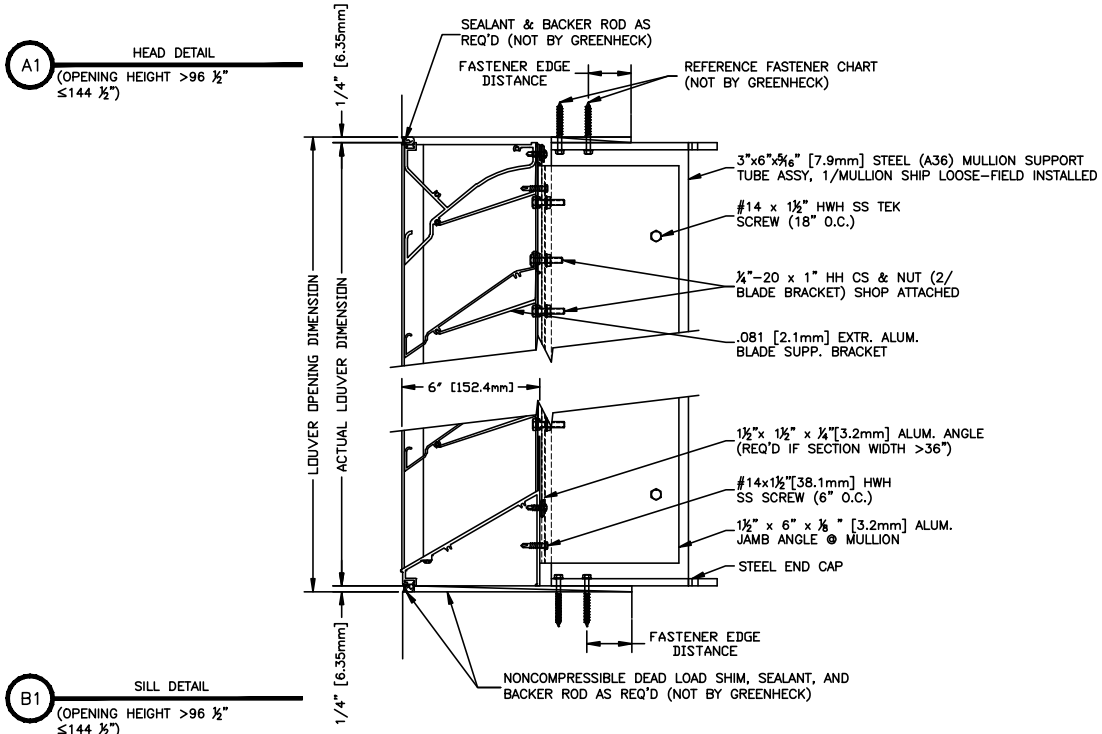

Multiple Sections

Height > 96 1/2 ≤ 144 1/2

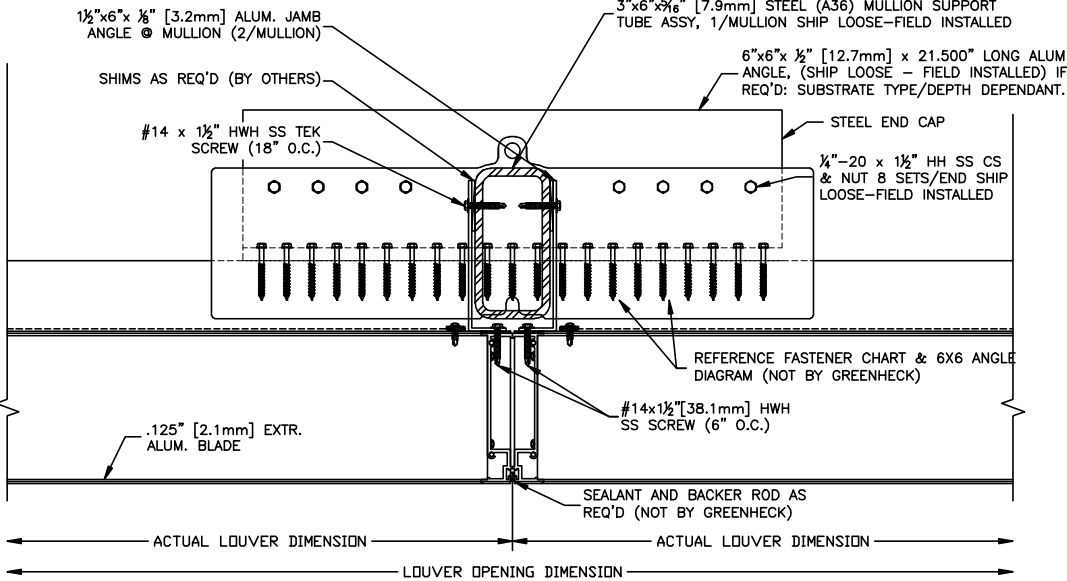
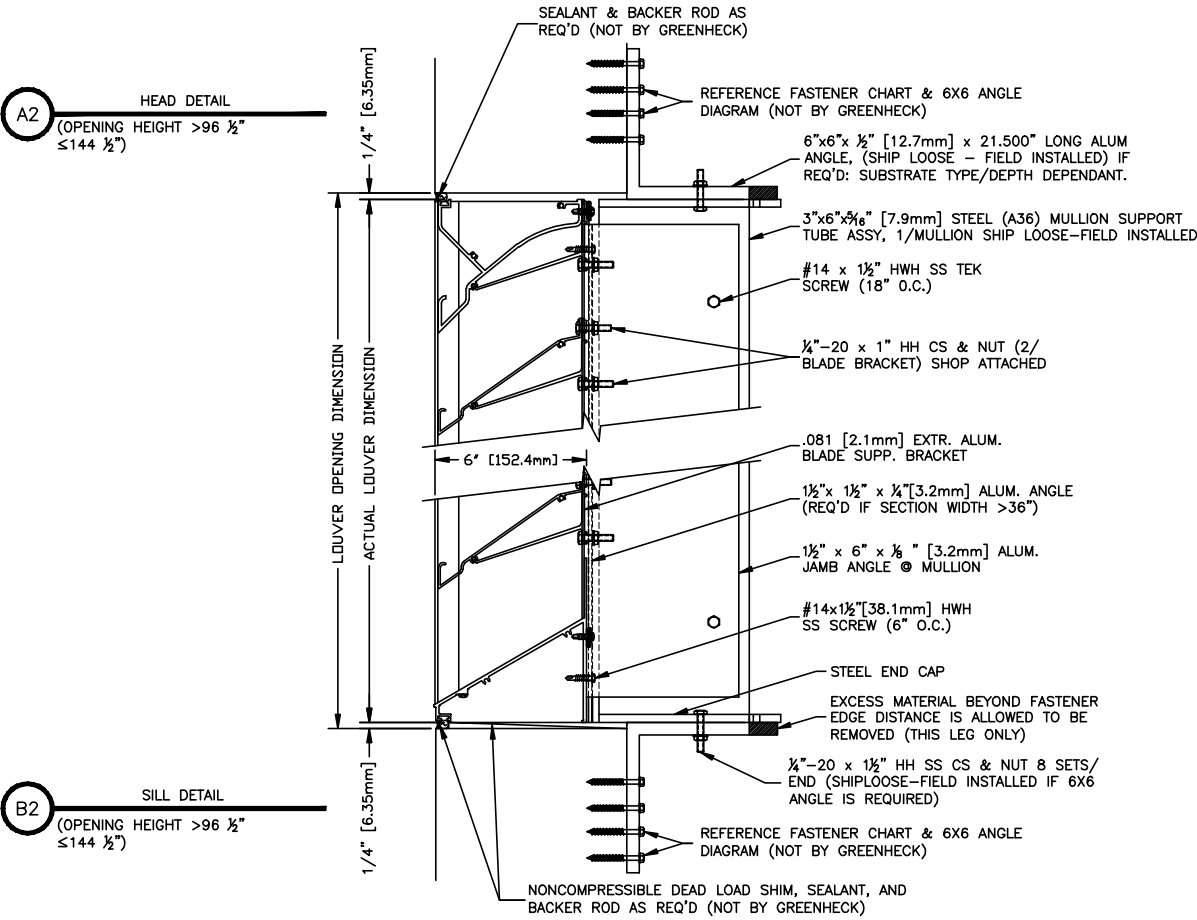

Single Section

Structure Depth

CMU / Concrete Substrate <ul style="list-style-type: none"> Min. structure depth 6.866 in. Max. structure depth infinite 	Steel Stud / Structural Steel Substrate <ul style="list-style-type: none"> Min. structure depth 5.866 in. Max. structure depth infinite
---------------------------------------------------------------------------------------------------------------------------------------------------------	------------------------------------------------------------------------------------------------------------------------------------------------------------------------

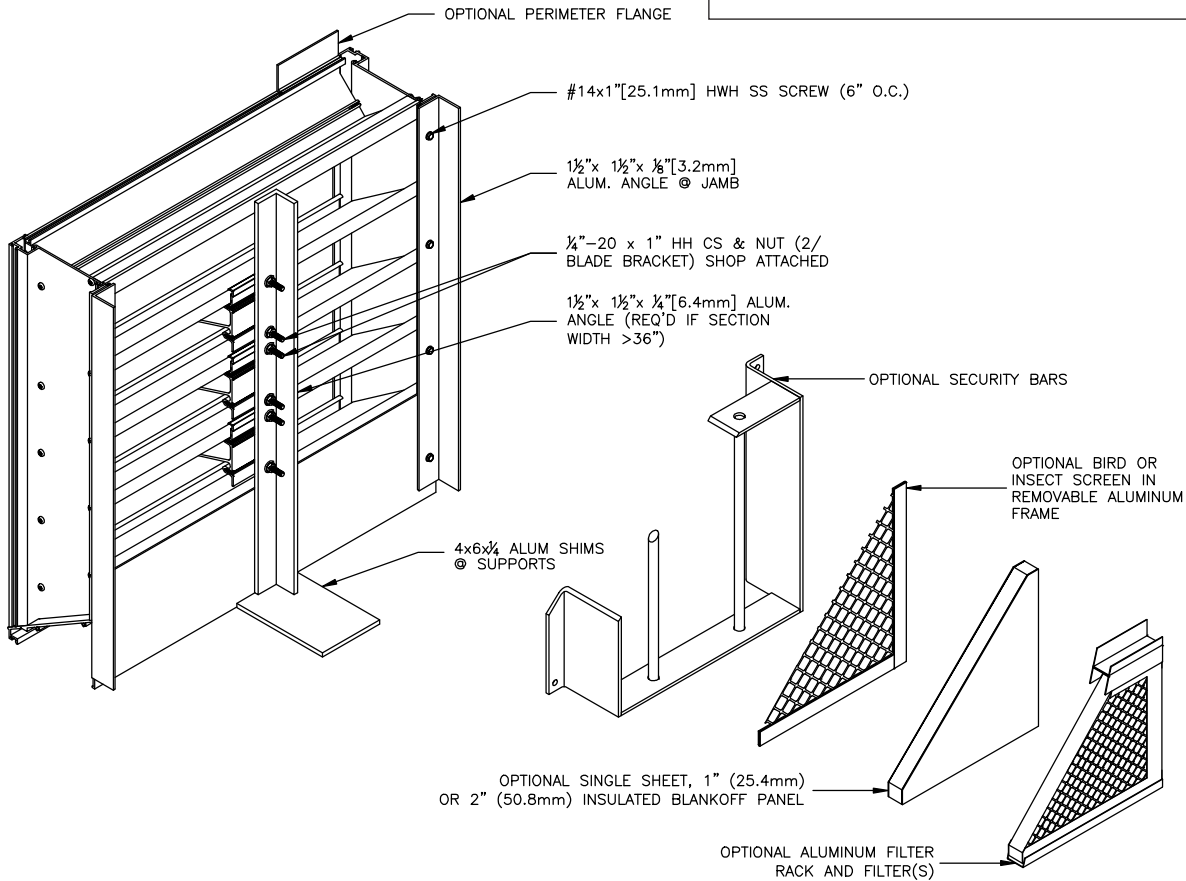

FASTENER SCHEDULE (FIELD INSTALLED - NOT BY GREENHECK)										
CONCRETE	CMU	STEEL	MIN.	FASTENER TYPE	ALL FASTENERS ARE STEEL OR STAINLESS					
JAMB PERIMETER ANGLE FASTNER					DIAMETER	# RQD.	CENTERS	EDGE	EMBED.*	
X			2KSI	SCOTS TAPCON / TAPCON	1/4	VARIES	4.750	1.500	1.750	
X			4KSI	SCOTS TAPCON / TAPCON	1/4	VARIES	6.000	1.500	1.750	
	X		1.5KSI	SCOTS TAPCON / TAPCON	1/4	VARIES	3.000	1.500	1.750	
		X	65KSI Fy	BOLT/NUT OR TAPPING SCREW	1/4	VARIES	6.000	0.500	0.125	
MULLION END PLATE FASTENER, HEIGHT <=144					DIAMETER	# RQD.	CENTERS	EDGE	EMBED.*	
X			2KSI	SCOTS TAPCON / TAPCON	1/4	9/END	2.000	1.500	1.625	
X			4KSI	SCOTS TAPCON / TAPCON	1/4	8/END	2.000	1.500	1.625	
	X		65KSI Fy	BOLT/NUT OR TAPPING SCREW	1/4	8/END	1.000	0.500	0.125	
MULLION ANGLE MOUNT FASTENER, HEIGHT <=144					DIAMETER	# RQD.	CENTERS	EDGE	EMBED.*	CENTER
X			2KSI	SCOTS TAPCON / TAPCON	1/4	32/ANG.	2.000	1.500	1.750	3.375
X			4KSI	SCOTS TAPCON / TAPCON	1/4	27/ANG.	2.000	1.500	1.750	3.375
	X		1.5KSI	SCOTS TAPCON / TAPCON	1/4	32/ANG.	2.000	1.500	1.750	3.375
		X	65KSI Fy	BOLT/NUT OR TAPPING SCREW	1/4	16/ANG.	1.000	0.500	0.125	3.000
		X	65KSI Fy	BOLT/NUT OR TAPPING SCREW	1/4	11/ANG.	1.000	0.500	0.188	3.000
		X	65KSI Fy	BOLT/NUT OR TAPPING SCREW	1/4	16/ANG.	1.000	0.500	0.188	3.766
MULLION END PLATE FASTENER, HEIGHT <=96					DIAMETER	# RQD.	CENTERS	EDGE	EMBED.*	
X			2KSI	SCOTS TAPCON / TAPCON	1/4	6/CAP	2.000	1.500	1.750	
X			4KSI	SCOTS TAPCON / TAPCON	1/4	6/CAP	2.000	1.500	1.750	
	X		65KSI Fy	BOLT/NUT OR TAPPING SCREW	1/4	3/CAP	1.000	0.500	0.125	
MULLION ANGLE MOUNT FASTENER, HEIGHT <=96					DIAMETER	# RQD.	CENTERS	EDGE	EMBED.*	CENTER
X			2KSI	SCOTS TAPCON / TAPCON	1/4	11/ANG.	2.000	1.500	1.750	3.375
X			4KSI	SCOTS TAPCON / TAPCON	1/4	9/ANG.	2.000	1.500	1.750	3.375
	X		1.5KSI	SCOTS TAPCON / TAPCON	1/4	11/ANG.	2.000	1.500	1.750	3.375
		X	65KSI Fy	BOLT/NUT OR TAPPING SCREW	1/4	7/ANG.	1.000	0.500	0.125	3.766
		X	65KSI Fy	BOLT/NUT OR TAPPING SCREW	1/4	6/ANG.	1.000	0.500	0.125	3.000



Multiple Sections

Height ≤ 96 1/2

Structure Depth		
<u>CMU Substrate</u>	<u>Concrete Substrate</u>	<u>Steel Stud / Structural Steel Substrate</u>
<ul style="list-style-type: none"> • Min. structure depth 6.866 in. • Max. structure depth 12.275 in. 	<ul style="list-style-type: none"> • Min. structure depth 6.866 in. • Max. structure depth infinite 	<ul style="list-style-type: none"> • Min. structure depth 5.866 in. • Max. structure depth infinite

HEAD DETAIL: MULLION DIRECT MOUNT: FOR SUBSTRATES WHERE MINIMUM FASTENER EDGE DISTANCE CAN BE ACHIEVED BY USE OF HOLES IN THE MULLION END CAP. (HEIGHT ≤ 96 1/2)

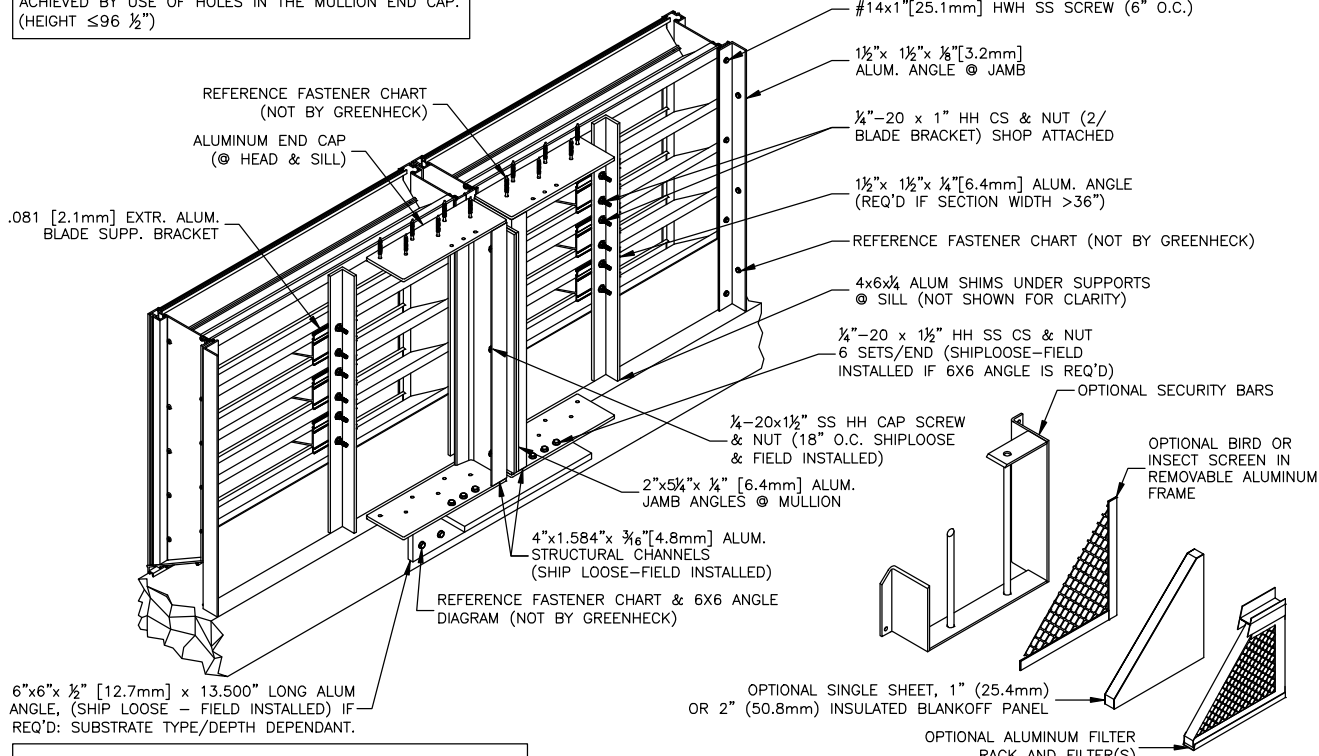

SILL DETAIL: MULLION ANGLE MOUNT: FOR SUBSTRATES WHERE MIN. FASTENER EDGE DISTANCE CANNOT BE ACHIEVED BY USE OF HOLES IN THE MULLION END CAP. (HEIGHT ≤ 96 1/2)

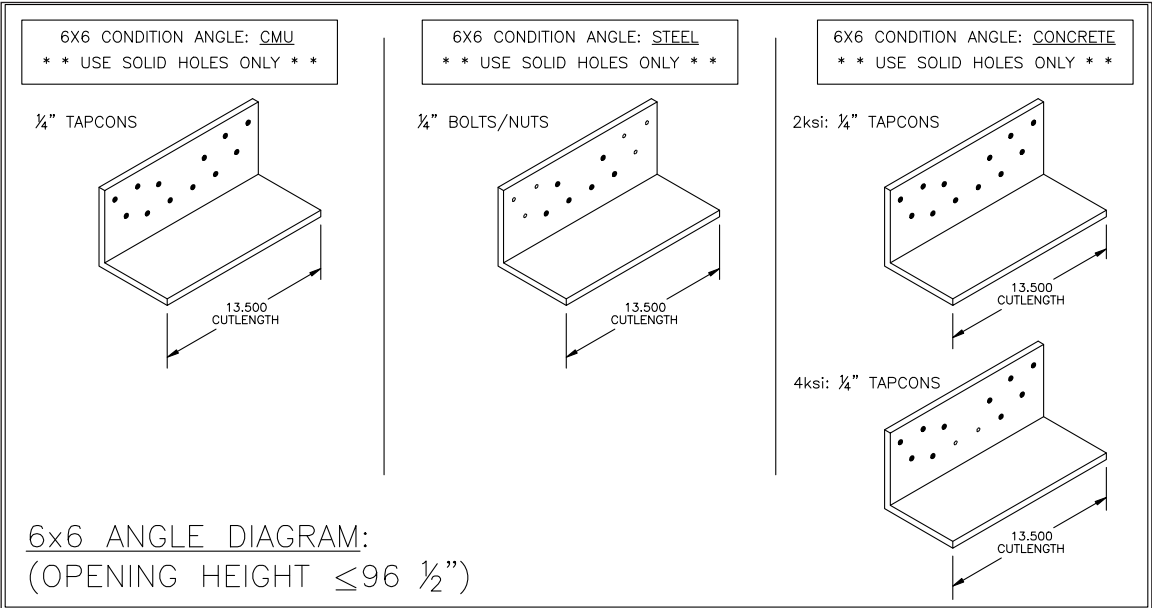

Multiple Sections

Height > 96 1/2" ≤ 144 1/2"

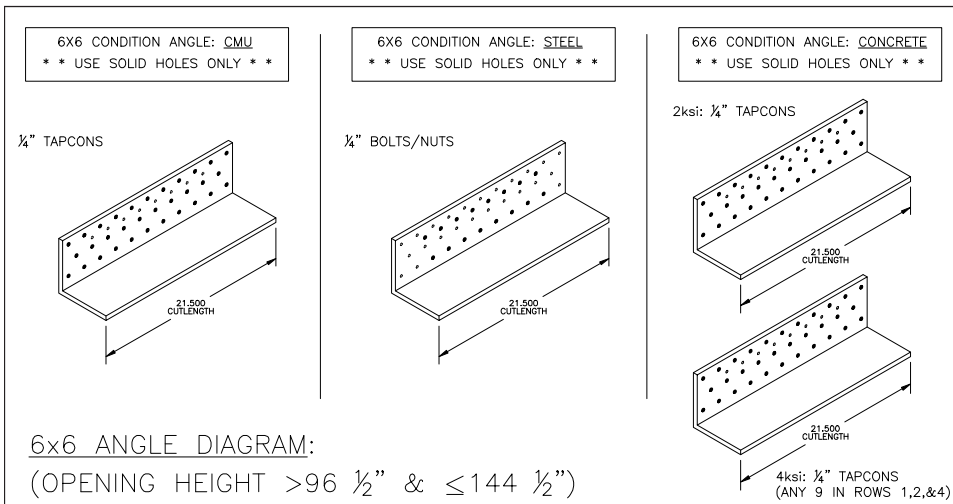
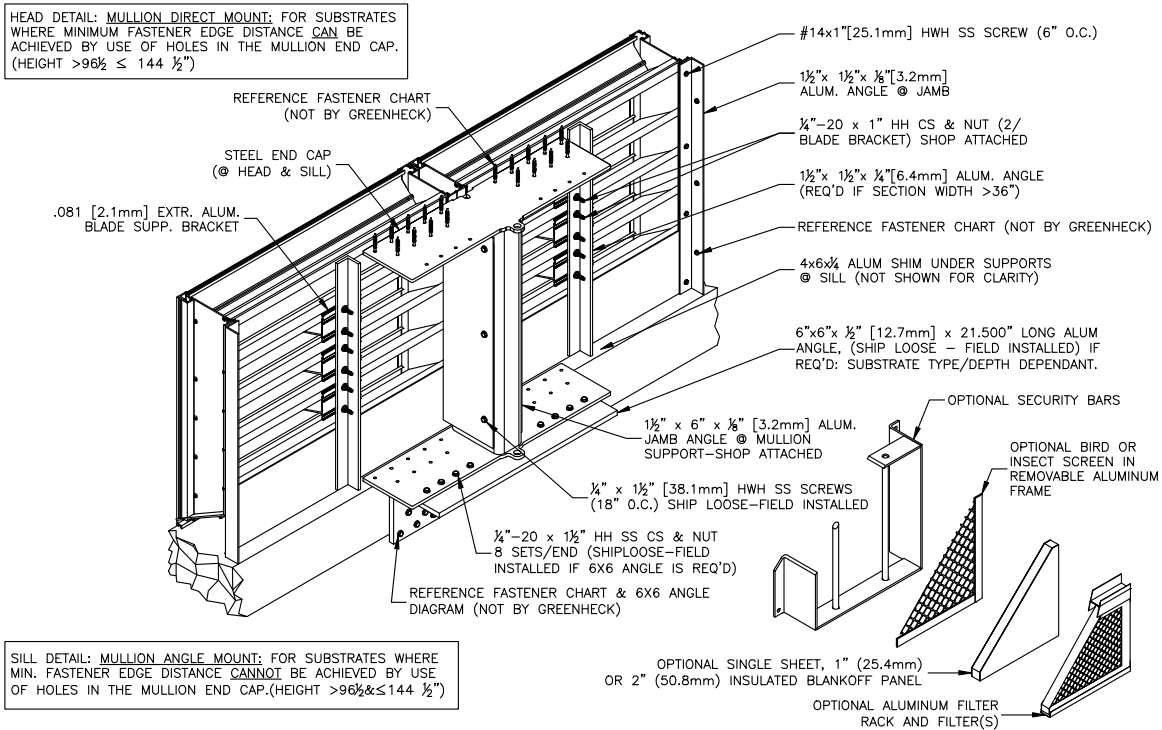

Structure Depth

CMU Substrate

- Min. structure depth 6.866 in.
- Max. structure depth 15.000 in.

Concrete Substrate

- Min. structure depth 6.866 in.
- Max. structure depth infinite

Steel Stud / Structural Steel Substrate

- Min. structure depth 5.866 in.
- Max. structure depth infinite

Our Commitment

As a result of our commitment to continuous improvement, Greenheck reserves the right to change specifications without notice.

Product warranties can be found online at Greenheck.com, either on the specific product page or in the literature section of the website at Greenheck.com/Resources/Library/Literature.

