

Installation, Operation and Maintenance Manual

Please read and save these instructions for future reference. Read carefully before attempting to assemble, install, operate or maintain the product described. Protect yourself and others by observing all safety information. Failure to comply with these instructions will result in voiding of the product warranty and may result in personal injury and/or property damage.

Maximum Wind-load: 150 PSF

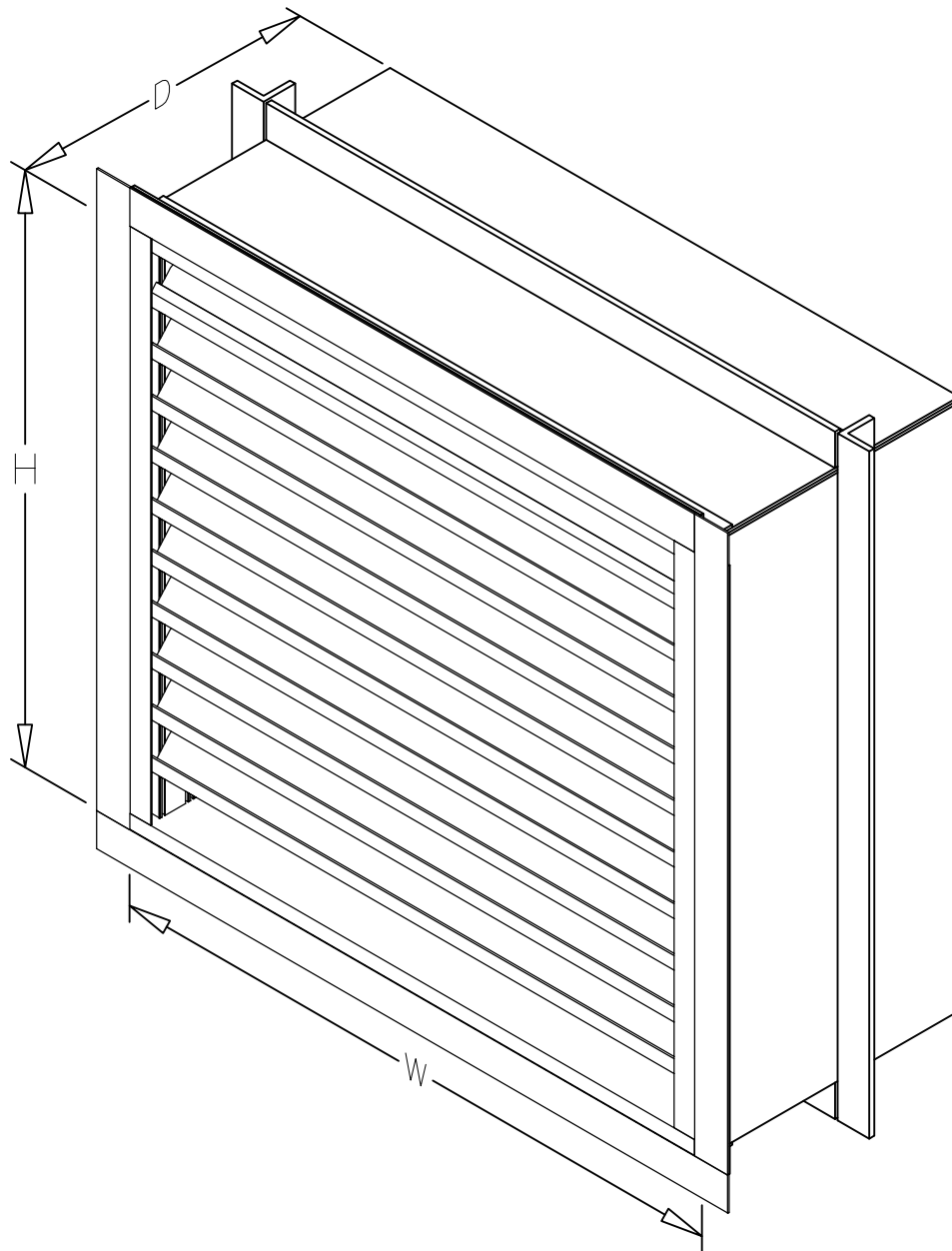

Maximum Size and Installation Information

Model EHH-601D with VCD-40 is a Miami-Dade Qualified and Florida Product Approved louver and must be installed in accordance with the installation instructions shown herein. Model EHH-601D with VCD-40 is qualified for installation within concrete/masonry, steel stud, structural steel or wood framed building conditions. Model EHH-601D with VCD-40 is structurally calculated to withstand positive and negative wind-loads up to 150 PSF. The maximum single section rough opening width is 36.538 in. The maximum single section rough opening height is 144.788 in. While the maximum rough opening height is limited to 144.788 in., the rough opening width is limited to 1,000 in. as multiple sections may be installed side by side in accordance with installation instructions.

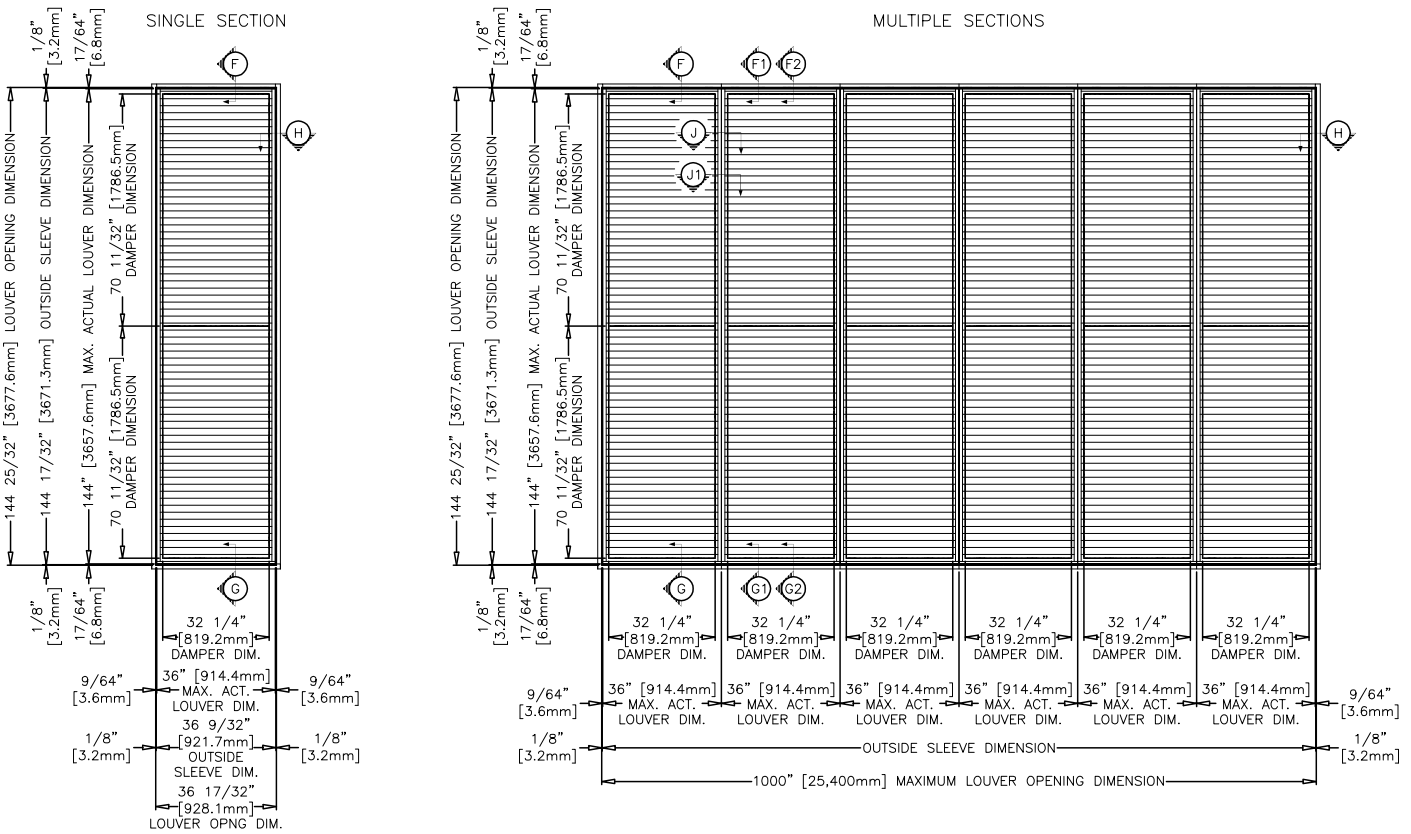

Building Condition/Substrate Limitations

- All wood substrate shall be G= 0.55 density or better
- All metal stud substrate should be min. 16 Ga. FY= 50 KSI
- All structural steel substrate shall be min. 0.25 in. thick FY= 36 KSI
- All concrete substrate shall be min. 3000 PSI
- Concrete masonry shall be ASTM C90, Type II, 2000 PSI, grout-filled

Single Section

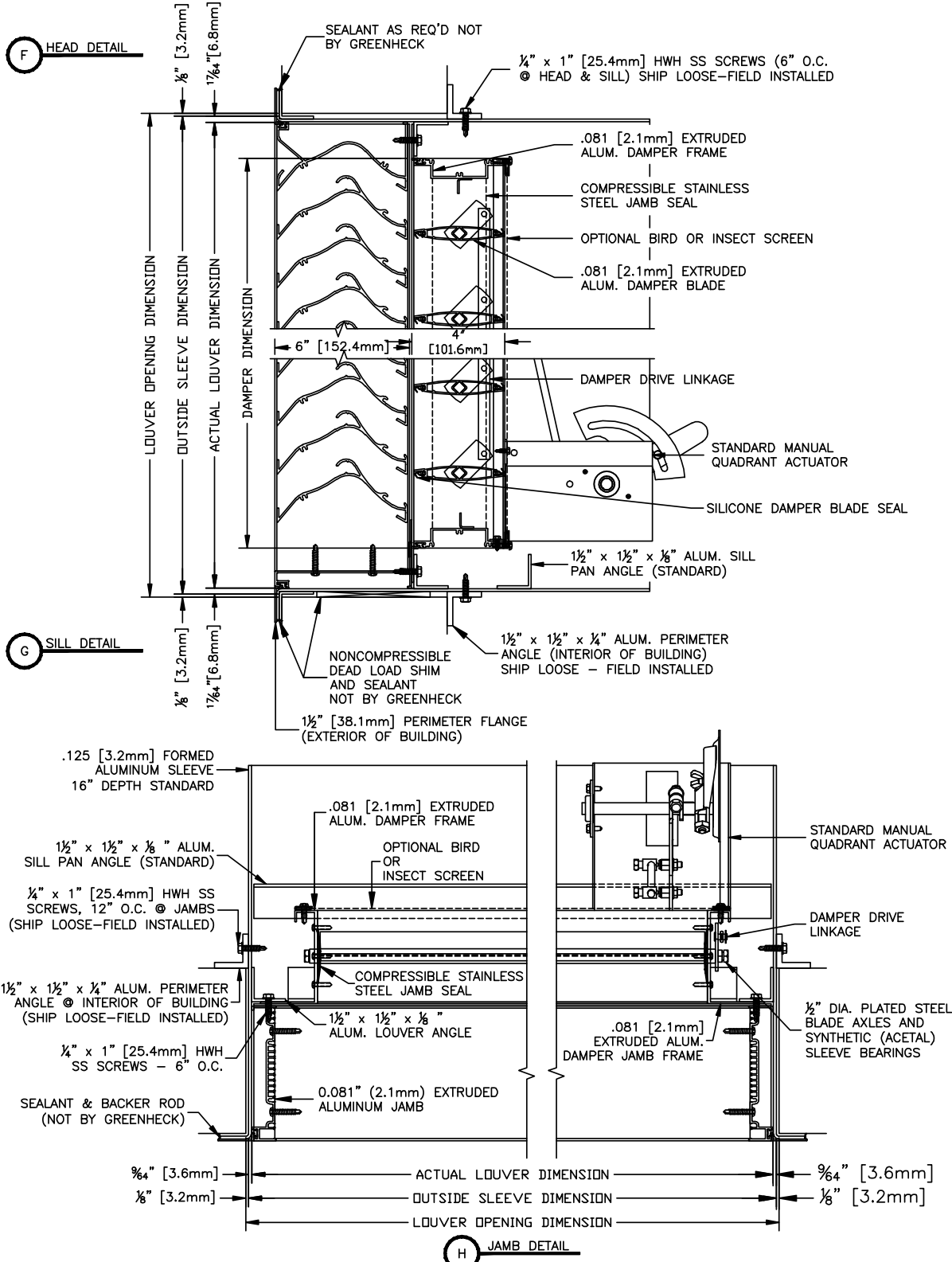

Multiple Sections

Height $\leq 96 \frac{1}{2}$

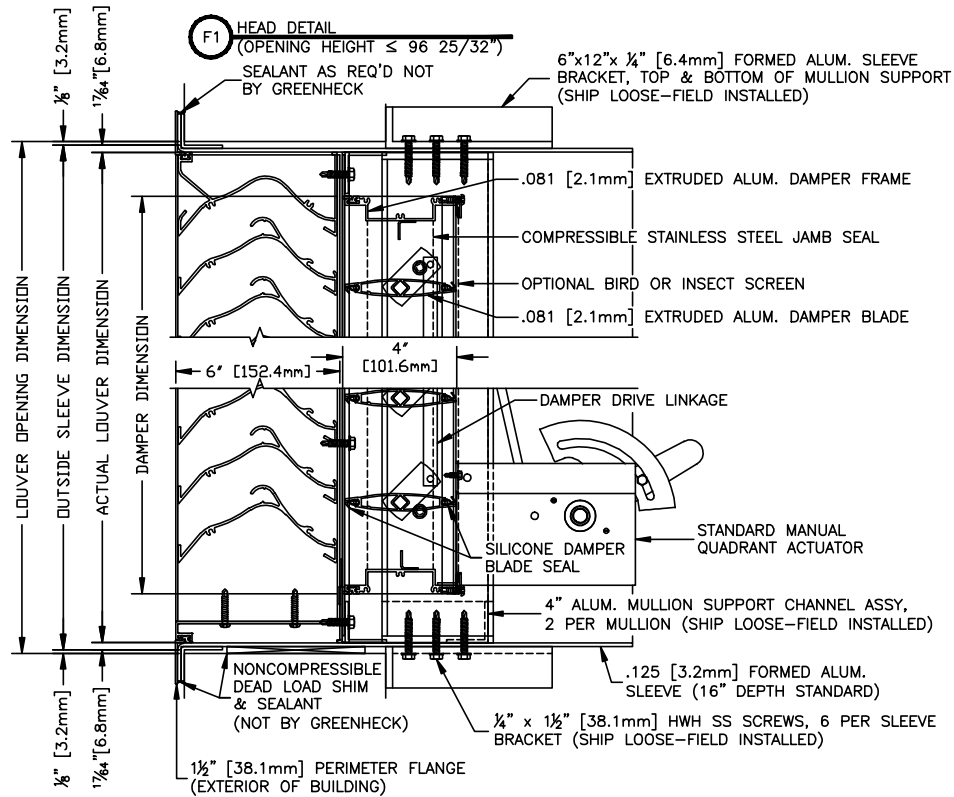

G1 SILL DETAIL (OPENING HEIGHT $\leq 96 \frac{25}{32}$ ")

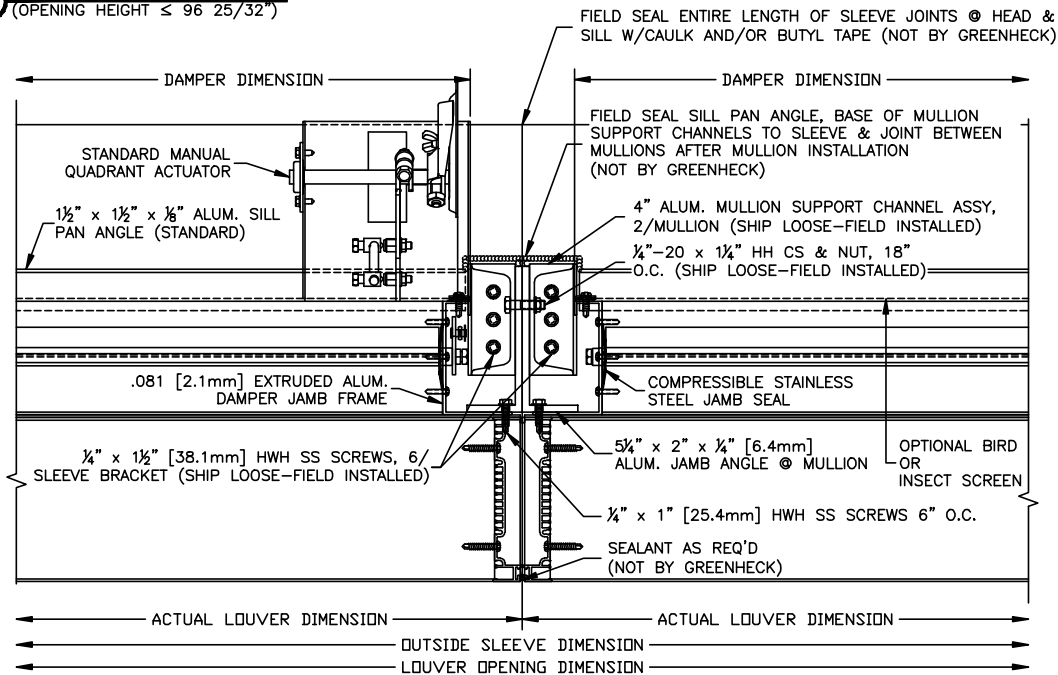

H1 MULLION DETAIL (OPENING HEIGHT $\leq 96 \frac{25}{32}$ ")



Multiple Sections

Height > 96 1/2 ≤ 144 1/2

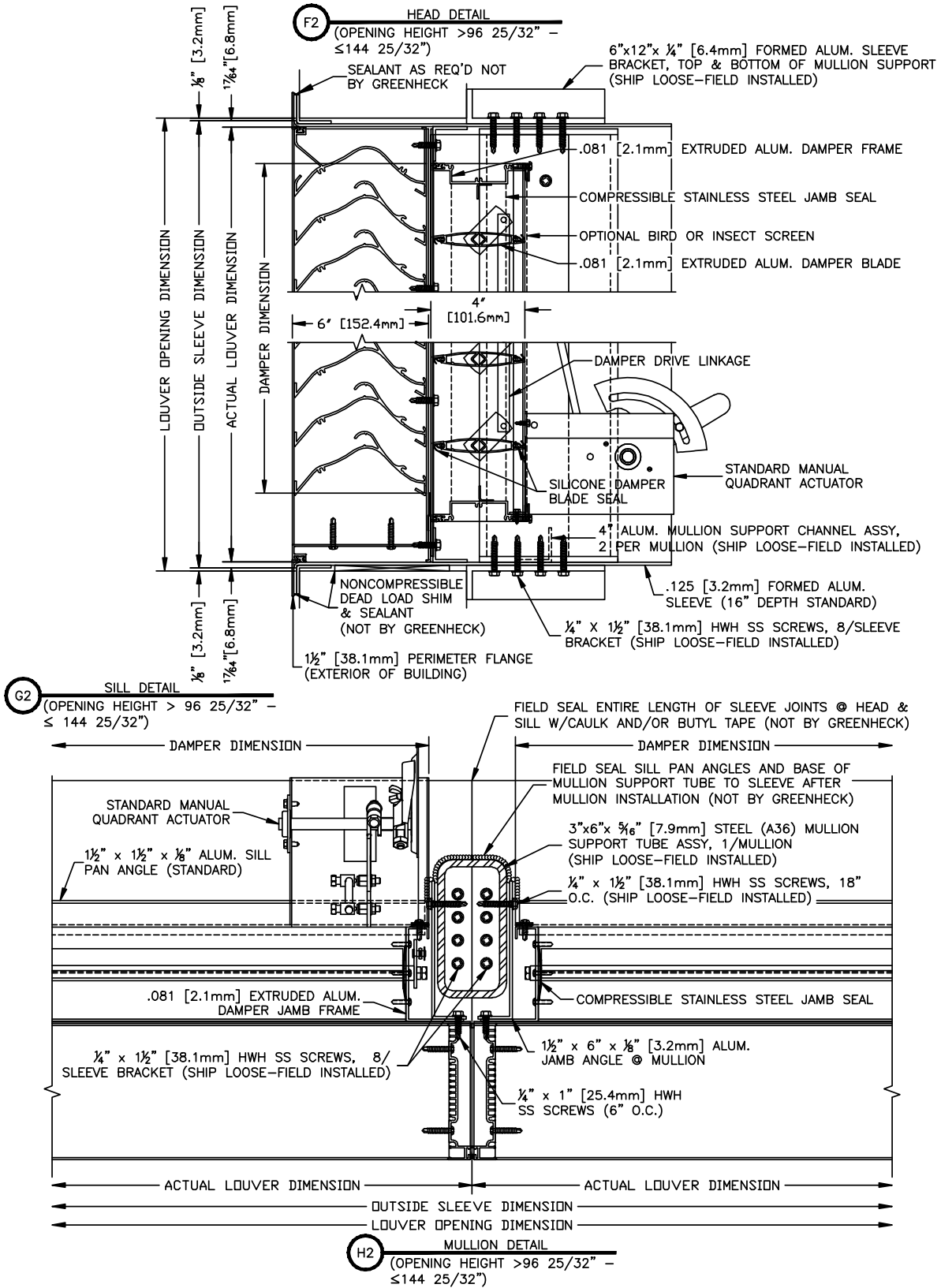

Single Section

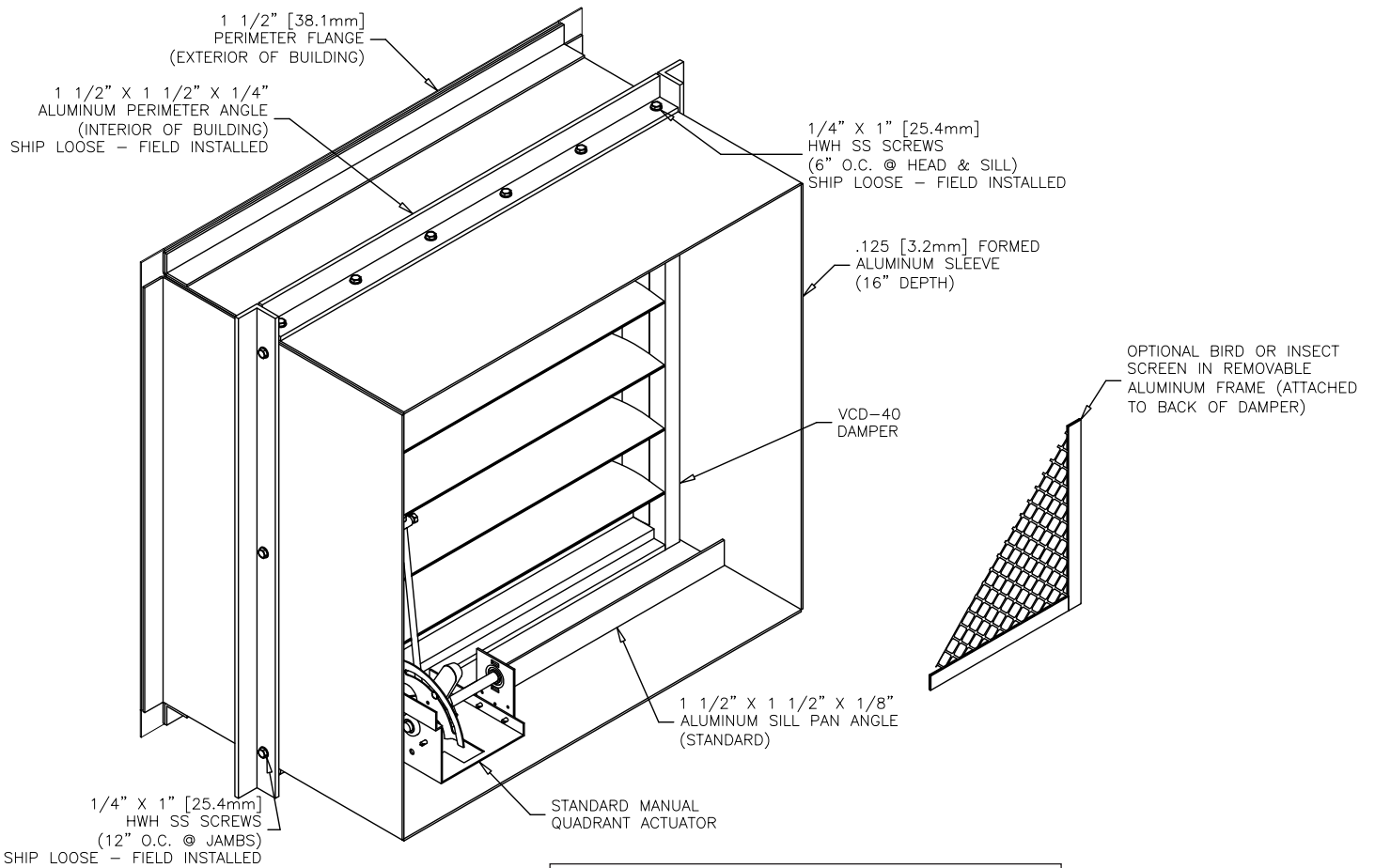

Structure Depth

- Min. structure depth 4 in.
- Max. structure depth 14.5 in.



Multiple Sections

Height ≤ 96 1/2

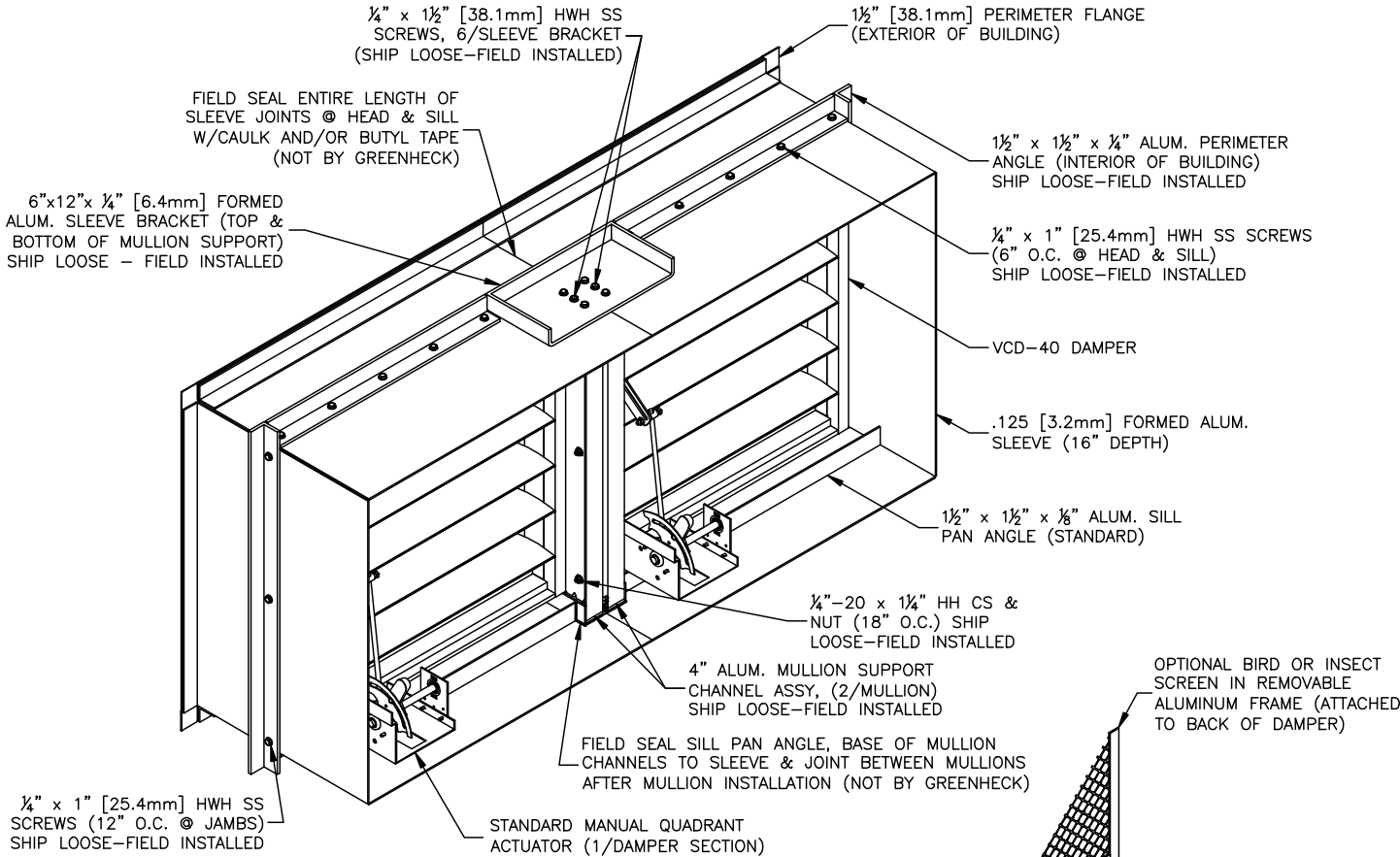

Structure Depth

- Min. structure depth 4 in.
- Max. structure depth 11.5 in.

Multiple Sections

Height > 96 1/2 ≤ 144 1/2

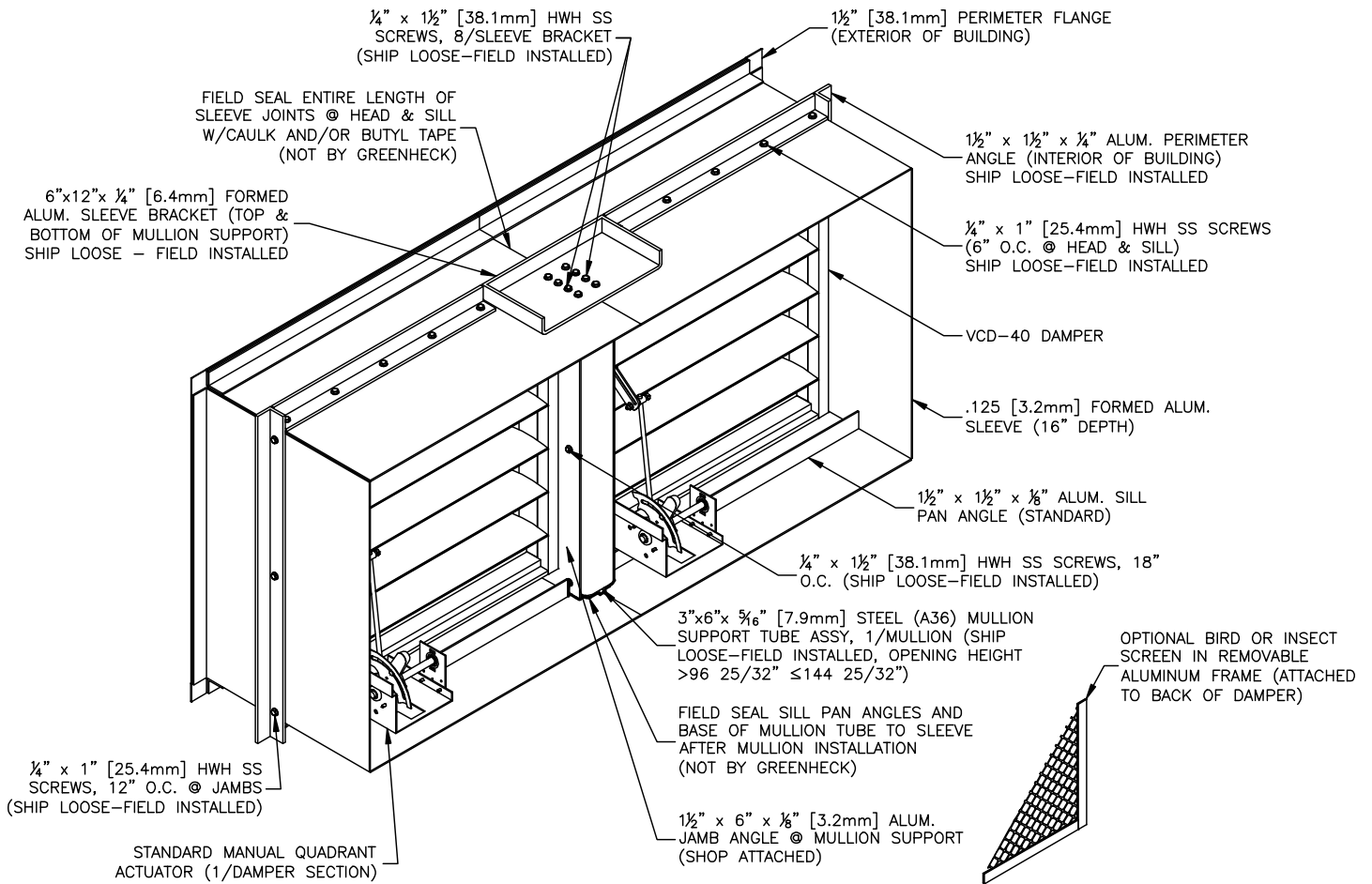

Structure Depth

- Min. structure depth 4 in.
- Max. structure depth 13.25 in.

Our Commitment

As a result of our commitment to continuous improvement, Greenheck reserves the right to change specifications without notice.

Product warranties can be found online at Greenheck.com, either on the specific product page or in the literature section of the website at Greenheck.com/Resources/Library/Literature.

