

Multiple Sections

Height > 96 1/2" ≤ 144 1/2"

HEAD DETAIL: MULLION DIRECT MOUNT; FOR SUBSTRATES WHERE MINIMUM FASTENER EDGE DISTANCE CAN BE ACHIEVED BY USE OF HOLES IN THE MULLION END CAP. (HEIGHT >96 1/2" & ≤144 1/2")

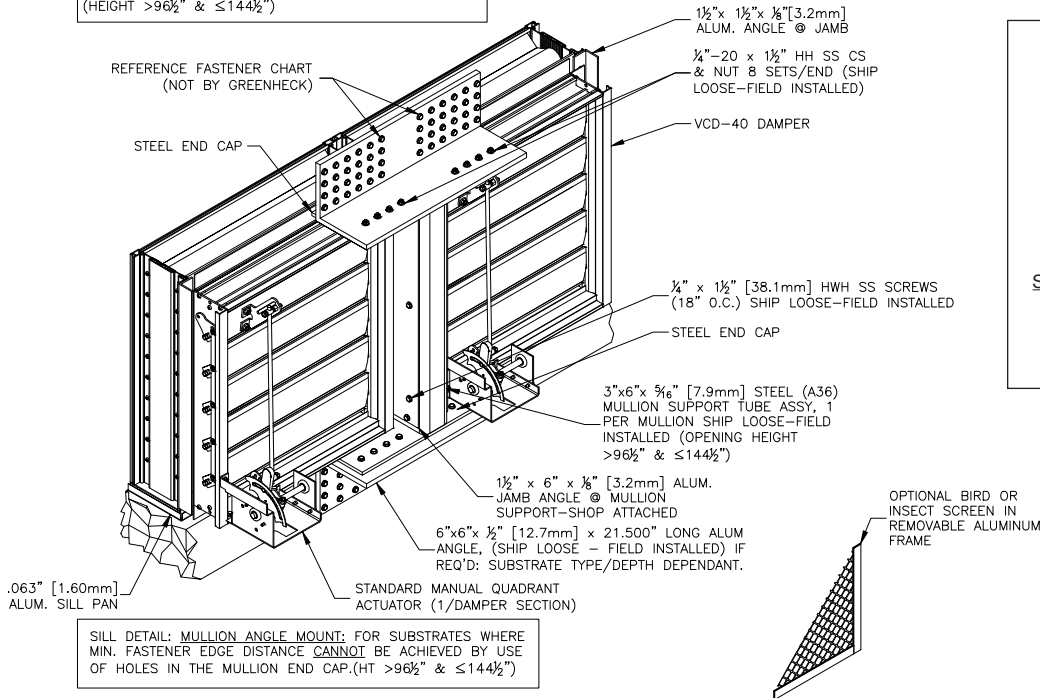

Structure Depth

- CMU Substrate**
 - Min. structure depth 6.866 in.
 - Max. structure depth 15.000 in.
- Concrete Substrate**
 - Min. structure depth 6.866 in.
 - Max. structure depth infinite
- Steel Stud / Structural Steel Substrate**
 - Min. structure depth 5.866 in.
 - Max. structure depth infinite

SILL DETAIL: MULLION ANGLE MOUNT; FOR SUBSTRATES WHERE MIN. FASTENER EDGE DISTANCE CANNOT BE ACHIEVED BY USE OF HOLES IN THE MULLION END CAP. (HT >96 1/2" & ≤144 1/2")

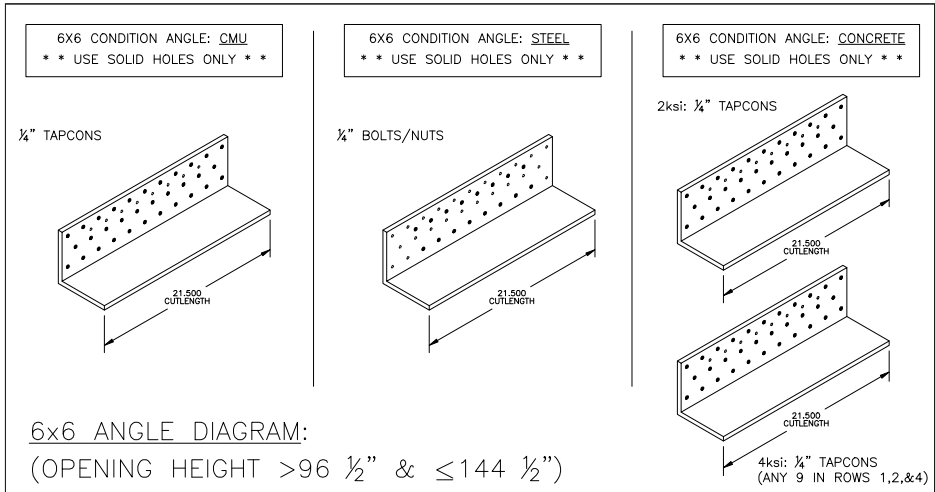

Our Commitment

As a result of our commitment to continuous improvement, Greenheck reserves the right to change specifications without notice.

Product warranties can be found online at Greenheck.com, either on the specific product page or in the literature section of the website at Greenheck.com/Resources/Library/Literature.

