

Installation, Operation and Maintenance Manual

Please read and save these instructions for future reference. Read carefully before attempting to assemble, install, operate or maintain the product described. Protect yourself and others by observing all safety information. Failure to comply with these instructions will result in voiding of the product warranty and may result in personal injury and/or property damage.

For Dampers Installed in Ducts

Extended control shaft is installed from outside of duct after damper is installed. Install as shown in this document.

Tools Required

$\frac{5}{16}$ in. Hex Nut Drive
 $\frac{3}{8}$ in. Electric Drill
 $\frac{1}{2}$ in. Open End Wrench

Extension Pin with Clip

Part Number 846031 Extension Pin with Clip			
Number	Qty	Description	Part Number
1	1	Extended Control Shaft	452509
2	1	Retaining Clip	451738

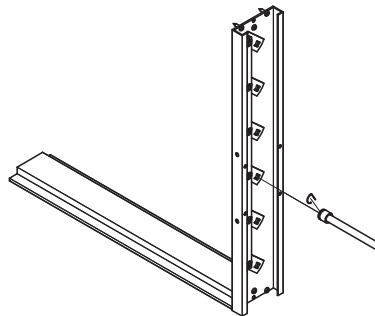
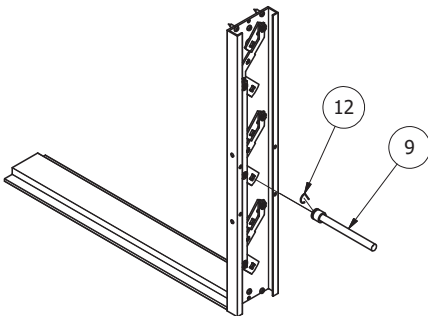

CROSSOVER BLADE AXLE
— DO NOT ATTACH CONTROL
SHAFT HERE!

Before Installing Damper in the Duct

1. If the damper has more than one blade, determine which blade axle will be driven by the extended control shaft. Always attach extended control shaft to a blade axle which is directly connected to the main linkage tiebar. DO NOT attach extended control shaft to a crossover blade axle.
2. Cut hole approximately 1 in. (25mm) diameter in duct where the damper drive blade axle will be located. Hole must provide clearance for enlarged portion of extended control shaft.

After Damper is Installed in the Duct

1. Push extended control shaft through the hole in the duct and onto the drive blade axle. Retainer clip should “click” into groove on the drive blade axle and hold the shaft into place.
Standard control shaft location in the third blade from the bottom on dampers with three or more blades. Control shaft location is the first blade from the bottom on dampers with one or two blades.

Extension Pin Kit

Part Number 913908			
½ in. Extension Pin Kit			
Number	Qty	Description	Part Number
1	1	Standoff Bracket	913562
2	1	Extension Pin	452509
3	1	Retaining Clip	451738
4	4	¼-20 Nut	415455
5	4	¼-20 x ½ Stud	415609

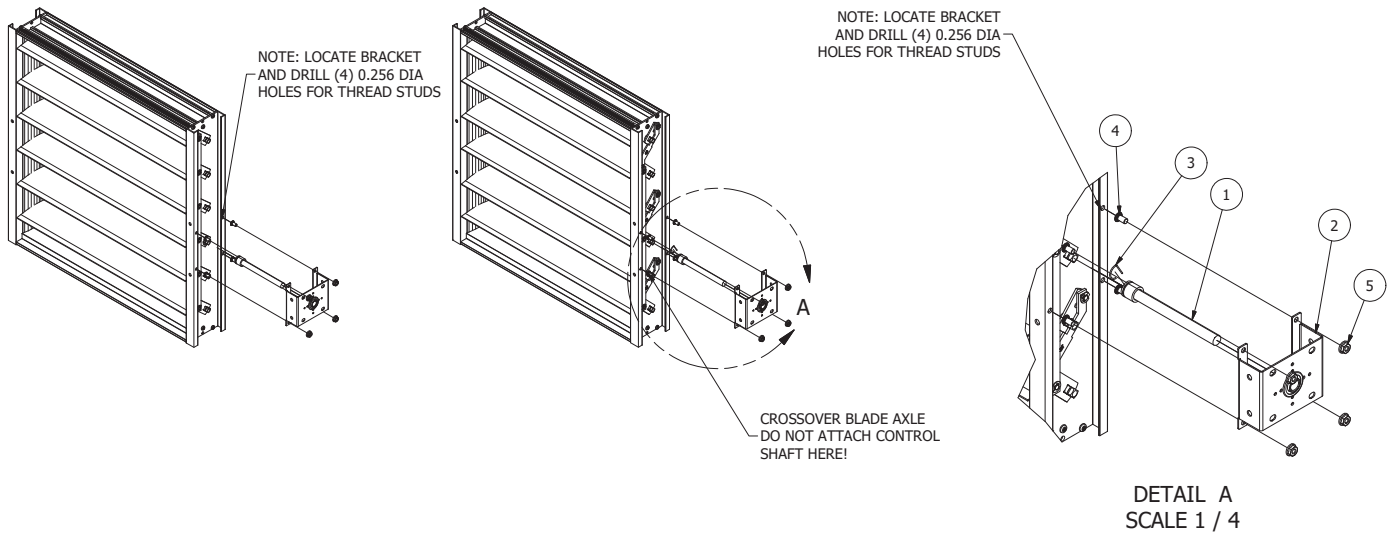

Before Installing Damper in the Duct

1. If the damper has more than one blade, determine which blade axle will be driven by the extended control shaft. Always attach extended control shaft to a blade axle which is directly connected to the main linkage tiebar. DO NOT attach extended control shaft to a crossover blade axle.
2. Cut hole approximately 1 in. (25mm) diameter in duct where the damper drive blade axle will be located. Hole must provide clearance for enlarged portion of the extended control shaft.

After Damper is Installed in the Duct

1. Push extended control shaft through the hole in the duct and onto the drive blade axle. Retainer clip should “click” into the groove on the drive blade axle and hold the shaft into place. Standard control shaft location is the third blade from the bottom on dampers with three or more blades. Control shaft location is the first blade from the bottom on dampers with one or two blades.
2. Install the stand off bracket with bearing over the extended control shaft and screw bracket to the duct. Make sure screws (provided by others) do not interfere with damper linkage or blade movement.

Manual Quadrant Kits with Extension Pin

Part Number 913910			
1/2 in. Extension Pin Kit with Manual Quadrant			
Number	Qty	Description	Part Number
1	1	Standoff Bracket	913562
2	1	Extension Pin	452509
3	1	Retaining Clip	451738
4	4	1/4-20 x 1/2 Stud	415609
5	4	1/4-20 Nut	415455
6	2	TEK screws	415555
7	1	Open & Closed Labels	452690
8	1	1/2 in. dia. Manual Quadrant	455648

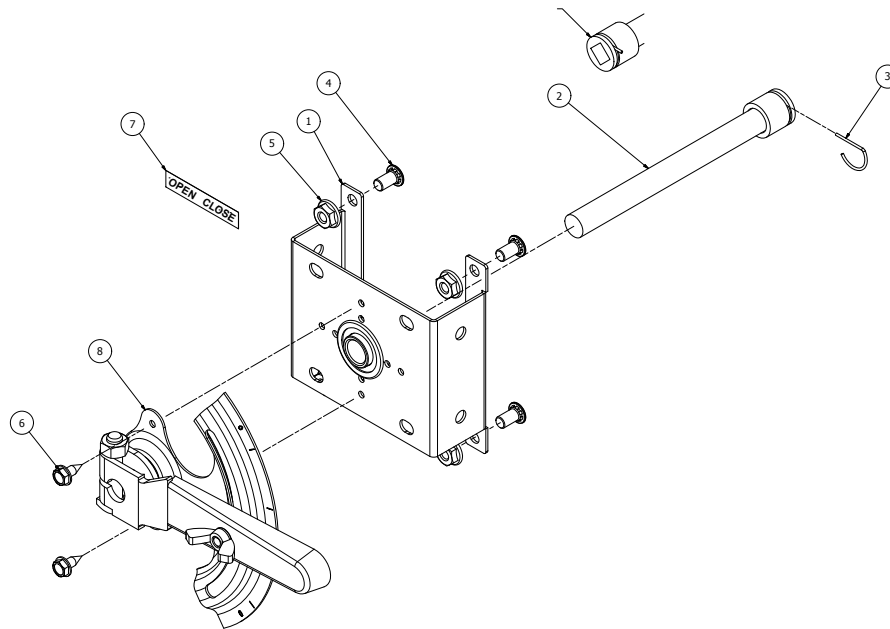

Part Number 813938			
1 in. Extension Pin Kit with Manual Quadrant			
Number	Qty	Description	Part Number
1	1	1 in. Quadrant Bracket	649366
2	1	Quadrant Lever Arm Assembly	814406
3	1	3/8 - 16 x 1 Short Shank Carriage Bolt	415820
4	1	5/8 in. Flat Washer	415381
5	1	3/8 - 16 Wing Nut	415821
6	1	3/8 - 16 x 2 1/2 in. Carriage Bolt	415485
7	1	3/8 - 16 Spinlock Nut ZP	415457
8	4	1/4 - 20 1/2 in. Self Threading Screw	415264
9	1	Open & Closed Labels	452690

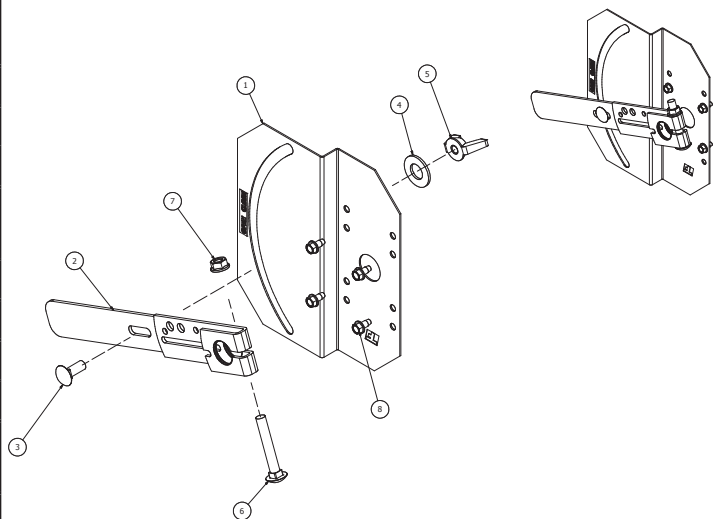

Manual Quadrant Kits with Extension Pin

Non-Jackshafted Dampers

Control damper should be mounted in the duct and the shaft extension mounted onto the correct blade of the damper before continuing with these instructions.

After Extended Shaft is Installed

1. The jackshaft is either ½ in. or 1 in. diameter depending upon the size of the damper. The manual quadrant kit for the ½ in. diameter jackshaft is part number 865085 and the manual quadrant kit for a 1 in. diameter jackshaft is part number 813938.
2. With the damper either fully open or closed, lock the manual quadrant to the jackshaft so the manual quadrants can move the damper between open and closed. Note: Tighten down the bolt on the manual quadrant to 250 in. lb. of torque. Apply “OPEN” and “CLOSED” labels if the damper movement is opposite to what is engraved on the manual quadrant.
3. Set the damper to the desired position and tighten the wing nut on the manual quadrant to hold the damper in place.

Jackshafted Dampers

1. The jackshaft is either ½ in. or 1 in. diameter depending upon the size of the damper. The manual quadrant kit for the ½ in. diameter jackshaft is part number 865085 and the manual quadrant kit for a 1 in. diameter jackshaft is part number 813938.
2. With the damper either fully open or closed, lock the manual quadrant to the jackshaft so the manual quadrant can move the damper between open and closed. Note: Tighten down the bolt on the manual quadrant to 250 in. lb. of torque. Apply “OPEN” and “CLOSED” labels if the damper movement is opposite to that engraved in the manual quadrant.
3. Set the damper to the desired position and tighten the wing nut on the manual quadrant to hold the damper in place.

Our Commitment

As a result of our commitment to continuous improvement, Greenheck reserves the right to change specifications without notice.

Product warranties can be found online at Greenheck.com, either on the specific product page or in the literature section of the website at Greenheck.com/Resources/Library/Literature.

