

Assembly Instructions

READ THROUGH THESE INSTRUCTIONS PRIOR TO STARTING ASSEMBLY.

Roof curbs are modular in construction and require field assembly.

Roof Curb Assembly Kit

Each roof curb will arrive in sections along with an assembly kit for field installation. Verify all roof curb sections and assembly kit(s) have arrived for each fan mark and are in good condition prior to signing the shipping receipt.

ASSEMBLY KIT CONTENTS			879433	879434
			Fan Size 15-33	Fan Size 36-54
Part Name	Part Number	Part Description	Quantity	Quantity
Hex Head Cap Screw	415780	316 SS, 3/8 x 1-1/4 inch	10	14
Hex Nut	415799	316 SS, 3/8 inch	10	14
Flat Washer	415800	316 SS, 3/8 inch	20	28
Lock Washer	415810	316 SS, 3/8 inch	10	14
Gasketing		1/4 x 1-1/2 inch Foam		
Caulk*		Silicone	1 tube	1 tube

*One tube of caulk is supplied per system.

ROOF CURB SECTIONS			
Fan Quantity	End Section(s)	Center Section(s)	Quantity of Roof Curb Assembly Kit(s)
2	2	0	1
3	2	1	2
4	2	2	3
5	2	3	4
6	2	4	5

TOOLS REQUIRED
• Cordless drill (electric or pneumatic)
• Utility knife
• Caulk gun
• Box end wrench with 9/16 inch socket for 3/8 inch bolt with 9/16 inch head

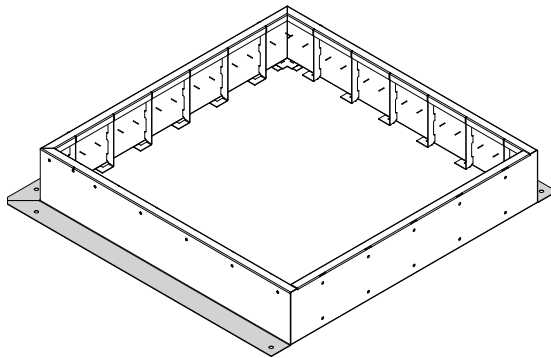

End Section
Flashing on three sides

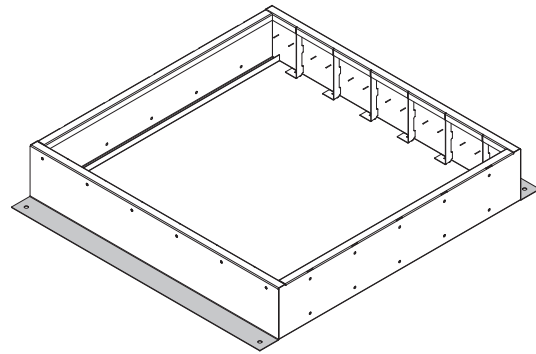

Center Section
Flashing on two sides

Assembly

Use one Roof Curb Assembly Kit with gasketing and hardware for each section to be joined. Attach self-adhering foam gasketing (supplied) to one side of either joining section (see Drawing 1a). Gasketing should be placed to form a continuous seal. Corner locations may need second strip to cover seam joints. Supplied hardware should then be used to secure the two sections together as shown (see Drawing 1b). Hold nut with wrench while bolt is tightened.

Drawing 1c shows two end panels and single center section. All sections and configurations are assembled in a similar manner.

Drawing 1a

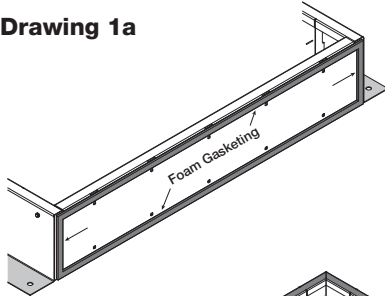

Drawing 1b

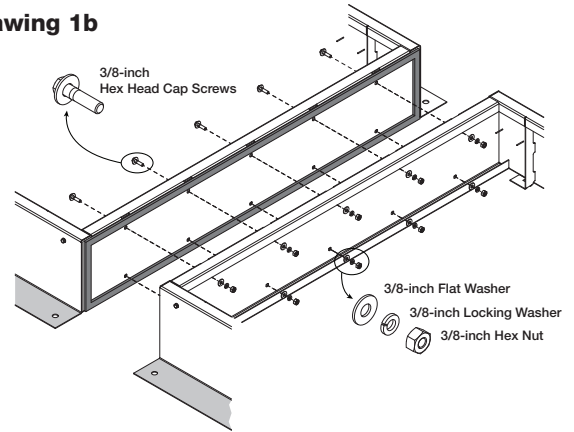

Drawing 1c

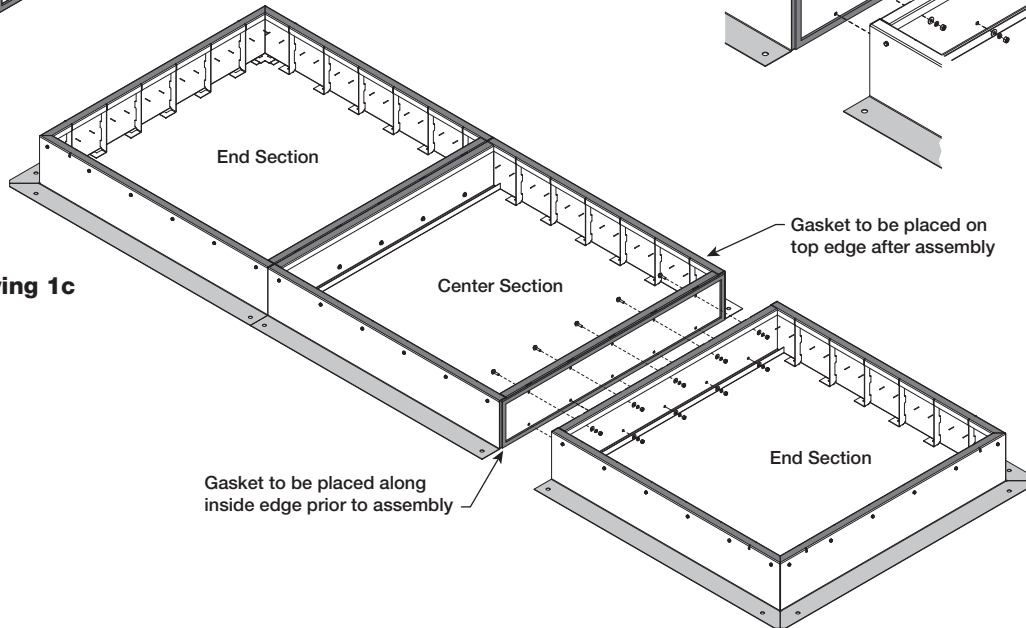

Sealing

After all sections have been assembled, caulk (supplied) all seam joints to provide final sealing of roof curb sections. Drawing 2 shows seams to be caulked. Follow caulk manufacturers recommendations for proper application.

Lifting

Roof curb can be assembled at installation location on the roof deck or at ground level and lifted into position. To lift from ground to roof deck, use spreader bar and support both end and center sections when lifting assembled curb.

Mounting

Attach curb to roof deck or support structure as specified by structural engineer.

