

Installation, Operation and Maintenance Manual

Please read and save these instructions for future reference. Read carefully before attempting to assemble, install, operate or maintain the product described. Protect yourself and others by observing all safety information. Failure to comply with these instructions will result in voiding of the product warranty and may result in personal injury and/or property damage.

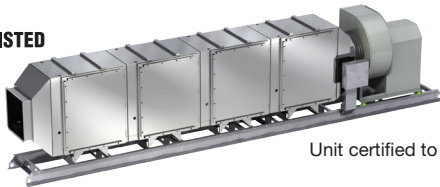

Unit certified to UL 8782

The Grease Trapper Pollution Control Unit (PCU) is a pre-engineered mechanical filtration pollution control unit with integral exhaust fan (available without exhaust fan as an option). The unit is designed to remove grease and odor molecules from the kitchen exhaust airstream. This installation manual covers procedures for receiving, installing, and maintaining the filtered section of the unit.

For additional instructions and maintenance information on the integral exhaust fan, when applicable, refer to the fan nameplate to determine model type and visit Greenheck.com to download the corresponding manual.

Table of Contents

Receiving, Unpacking, Handling, Storage	2
Grease Trapper System Function	3
System Components.	4
PCU Field Assembly	
Unit Modules.	5
Attaching Fan	6
Installation	
Rigging and Placing Equipment	7
Ductwork & Plumbing Connections	7
Remote Filter Status Indicator Panel	8
Filter Installation	8
Electrical Connections	9
Fire System.	10
Operation	
Start-Up	11
Remote Filter Status Indicator	11
Filter Replacement	11
Carbon Tray Replacement	11
Controller Setup and Tutorial	12-18
Keypad Navigation	19
Maintenance	
Variable Frequency Drive (VFD)	20
Regular Scheduled Maintenance	23
Replacement Filter - Parts Ordering.	23
Unit Layout - Elevation Views	24
Wiring Diagrams	25- 27
Our Commitment.	28

General Safety Information

Only qualified personnel should install this system. Personnel should have a clear understanding of these instructions and should be aware of general safety precautions. Improper installation can result in electric shock, possible injury due to coming in contact with moving parts, as well as other potential hazards. Other considerations may be required if high winds or seismic activity are present. If more information is needed, contact a licensed professional engineer before moving forward.

- Follow all local electrical and safety codes, as well as the National Electrical Code (NEC), and the National Fire Protection Agency (NFPA), where applicable. Follow the Canadian Electric Code (CEC) in Canada.
- The rotation of the fan wheel is critical. It must be free to rotate without striking or rubbing any stationary objects.
- Fan motor must be securely and adequately grounded.
- Do not spin fan wheel faster than maximum cataloged fan rpm. Adjustments to fan speed significantly effects motor load. If the fan RPM is changed, the motor current should be checked to make sure it is not exceeding the motor nameplate amps.
- Do not allow the power cable to kink or come in contact with oil, grease, hot surfaces or chemicals. Replace cord immediately if damaged.
- Verify that the power source is compatible with the equipment.
- Never open access doors to a duct while the fan is running.

DANGER

Always disconnect power before working on or near a fan. Lock and tag the disconnect switch or breaker to prevent accidental power up.

CAUTION

When servicing the fan, motor may be hot enough to cause pain or injury. Allow motor to cool before servicing.

CAUTION

Precaution should be taken in explosive atmospheres.

Receiving

Upon receiving the product, check to make sure all items are accounted for by referencing items shown on the packing list. Inspect each crate for shipping damage before accepting delivery. Notify the carrier if any damage is noticed. The carrier will make a notation on the delivery receipt acknowledging any damage to the product. All damage should be noted on all the copies of the bill of lading which is countersigned by the delivering carrier. A Carrier Inspection Report should be filled out by the carrier upon arrival and filed with the Traffic Department. If damaged upon arrival, file claim with carrier. Any physical damage to the unit after acceptance is not the responsibility of manufacturer.

Unpacking

Verify that all required parts and the correct quantity of each item have been received. If any items are missing, report shortages to your local representative to arrange for obtaining missing parts. Sometimes it is not possible that all items for the unit be shipped together due to availability of transportation and truck space. Confirmation of shipment(s) must be limited to only items on the bill of lading. Remove all other shipping/packing materials including fan tie down straps.

Handling

Units are to be rigged and moved by the lifting brackets provided or by the skid when a forklift is used. Location of brackets varies by model and size. Handle in such a manner as to keep from scratching or chipping the coating. Damaged finish may reduce ability of unit to resist corrosion.

Storage

Units are protected against damage during shipment. If the unit cannot be installed and operated immediately, precautions need to be taken to prevent deterioration of the unit during storage. The user assumes responsibility of the unit and accessories while in storage. The manufacturer will not be responsible for damage during storage. These suggestions are provided solely as a convenience to the user.

INDOOR - The ideal environment for the storage of units and accessories is indoors, above grade, in a low humidity atmosphere which is sealed to prevent the entry of blowing dust, rain, or snow. Temperatures should be evenly maintained between 30°F (-1°C) and 110°F (43°C) (wide temperature swings may cause condensation and “sweating” of metal parts). All accessories must be stored indoors in a clean, dry atmosphere.

Remove any accumulations of dirt, water, ice, or snow and wipe dry before moving to indoor storage. To avoid “sweating” of metal parts allow cold parts to reach room temperature. To dry parts and packages, use a portable electric heater to get rid of any moisture buildup. Leave coverings loose to permit air circulation and to allow for periodic inspection.

OUTDOOR - Units designed for outdoor applications may be stored outdoors, if absolutely necessary. Roads or aisles for portable cranes and hauling equipment are needed.

The unit should be placed on a level surface to prevent water from leaking into it. The unit should be elevated on an adequate number of wooden blocks so that it is above water and snow levels and has enough blocking to prevent it from settling into soft ground. Locate parts far enough apart to permit air circulation, sunlight, and space for periodic inspection. To minimize water accumulation, place all unit parts on blocking supports so that rain water will run off.

Do not cover parts with plastic film or tarps as these cause condensation of moisture from the air passing through heating and cooling cycles.

Inspection and Maintenance during Storage

While in storage, inspect fans once per month. Keep a record of inspection and maintenance performed.

If moisture or dirt accumulations are found on parts, the source should be located and eliminated. At each inspection, rotate the fan wheel by hand ten to fifteen revolutions to distribute lubricant on motor. Every three months, the fan motor should be energized. Fans with special coatings may require special techniques for touch-up or repair.

Machined parts coated with rust preventive should be restored to good condition promptly if signs of rust occur. Immediately remove the original rust preventive coating with petroleum solvent and clean with lint-free cloths. Polish any remaining rust from surface with crocus cloth or fine emery paper and oil. Do not destroy the continuity of the surfaces. Wipe thoroughly clean with Tectyl® 506 (Ashland Inc.) or the equivalent. For hard to reach internal surfaces or for occasional use, consider using Tectyl® 511M Rust Preventive or WD-40® or the equivalent.

Removing from Storage

As units are removed from storage to be installed in their final location, they should be protected and maintained in a similar fashion, until the equipment goes into operation. Prior to installing the unit and system components, inspect the unit assembly to make sure it is in working order.

1. Check all fasteners, set screws on the fan, wheel, bearings, drive, motor base, and accessories for tightness.
2. Rotate the fan wheel(s), where applicable, by hand and assure no parts are rubbing.

Grease Trapper System Function

Grease Trapper is a multistage mechanical air filtration unit, with an optional carbon filter module. It is designed for two specific functions:

1. Remove grease particulate from kitchen exhaust.
2. Remove odor molecules from kitchen exhaust.

NOTE

- Grease Trapper must be connected to a listed exhaust hood assembly and must be installed in accordance with local building codes, NFPA 96 and NEC.
- The unit must be installed with a minimum 12 inch clearance to combustible materials on top of unit, and six inches on the sides and bottom.

Each mechanical filter stage is monitored by an individual pressure switch that signals when a particular filter stage needs filters to be replaced. When a filter stage requires replacement, a signal from the pressure switch(es) illuminates an indicator light located on the Remote Filter Status Indicator Panel (if provided), or triggers a fault to be displayed on the keypad (if provided), or sends a signal to the BMS over a communication protocol (if configured).

NOTE

Grease Trapper is designed to remove submicron, airborne particulate generated from cooking processes. This system is **NOT INTENDED** to eliminate regular hood and ductwork cleaning and service. Improper care and maintenance of this system and associated hoods and ductwork may present a fire hazard.

System Components

Unit Body

The unit body is shipped on a common mounting rail ready for installation. If the unit was ordered with an exhaust fan and the housing size is not 180 or 270, the fan will also be mounted on the unit. If the unit was ordered with an exhaust fan and the housing size is 180 or 270, the fan will ship separate from the unit. If unit must be disassembled in the field, refer to instructions on page 5.

Filters

Filter quantity for each filter stage is based on unit size. A consistent quantity of filters is provided for each stage of filtration.

Filter Quantity				
Housing	Metal Mesh	MERV 8	MERV 15	Carbon Filters
30	3	3	3	6
45	4	4	4	10
60	6	6	6	14
90	8	8	8	20
120	12	12	12	28
180	16	16	16	40
270	24	24	24	60

Remote Filter Status Indicator Panel *(if provided)*

A remote filter status indicator panel may be provided depending on the unit configuration. This panel provides indicator lights which illuminate when a module's filters are completely loaded. This item must be mounted remotely in the cooking area prior to unit start-up, so that it can be monitored by the cook staff. See page 27 for wiring information.

Fire Cabinet *(if provided)*

If provided, the fire cabinet should be mounted as close to the Pollution Control Unit as possible, typically within 5 feet. Unless the fire cabinet was provided with an outdoor cabinet and heater, the cabinet should be mounted indoors and must be kept above freezing. See pages 26 and 27 for heater controller schematics and programming information.

System Control Panel *(if provided)*

The system control panel fed from a 15A building breaker allows the user to interface with the unit and controls operation, and monitors wash and other functions. Unless factory mounted on the rails of the unit, pressure tubing needs to be run from unit modules to system control panel in the field. The system control panel has both indoor (NEMA-1) and outdoor (NEMA-4) enclosure options that can be mounted on the unit rails or shipped loose. Follow 110-26 of National Electrical Code in allowing adequate room for electrical servicing as well as allowing clearance for opening any access or service doors.

Ship Loose VFD *(if provided)*

If configured to include a VFD and fan HP is greater than 25HP, the unit will be provided with a ship loose VFD to be remote mounted. VFD will come pre-mounted inside a NEMA 3R outdoor rated enclosure. See wiring diagram provided with unit for wiring details to connect main PCU control panel to VFD. See unit specific wiring diagram for field wiring/connection details.

Keypad *(if provided)*

Unit may be provided with a ship loose push button keypad. Keypad will be provided with a 35, 75, or 150 foot RJ25 cable to field connect the keypad to the main control panel.



PCU Field Assembly - if applicable

If unit is shipped in sections, each section will **need to be assembled in the field**.

Unit Modules

1. Remove (4) 5/16 inch mechanical fasteners that attach each module to the rails.
2. Remove 5/16 inch mechanical fasteners that attach each module to the next adjacent module. PCU housing size can be found in the model number on tag on side of unit.

Fasteners Attaching Each Module to Next Adjacent Module	
Housing Size	Number of Mechanical Fasteners
30, 45	4
60, 90, 120, 180, 270	6

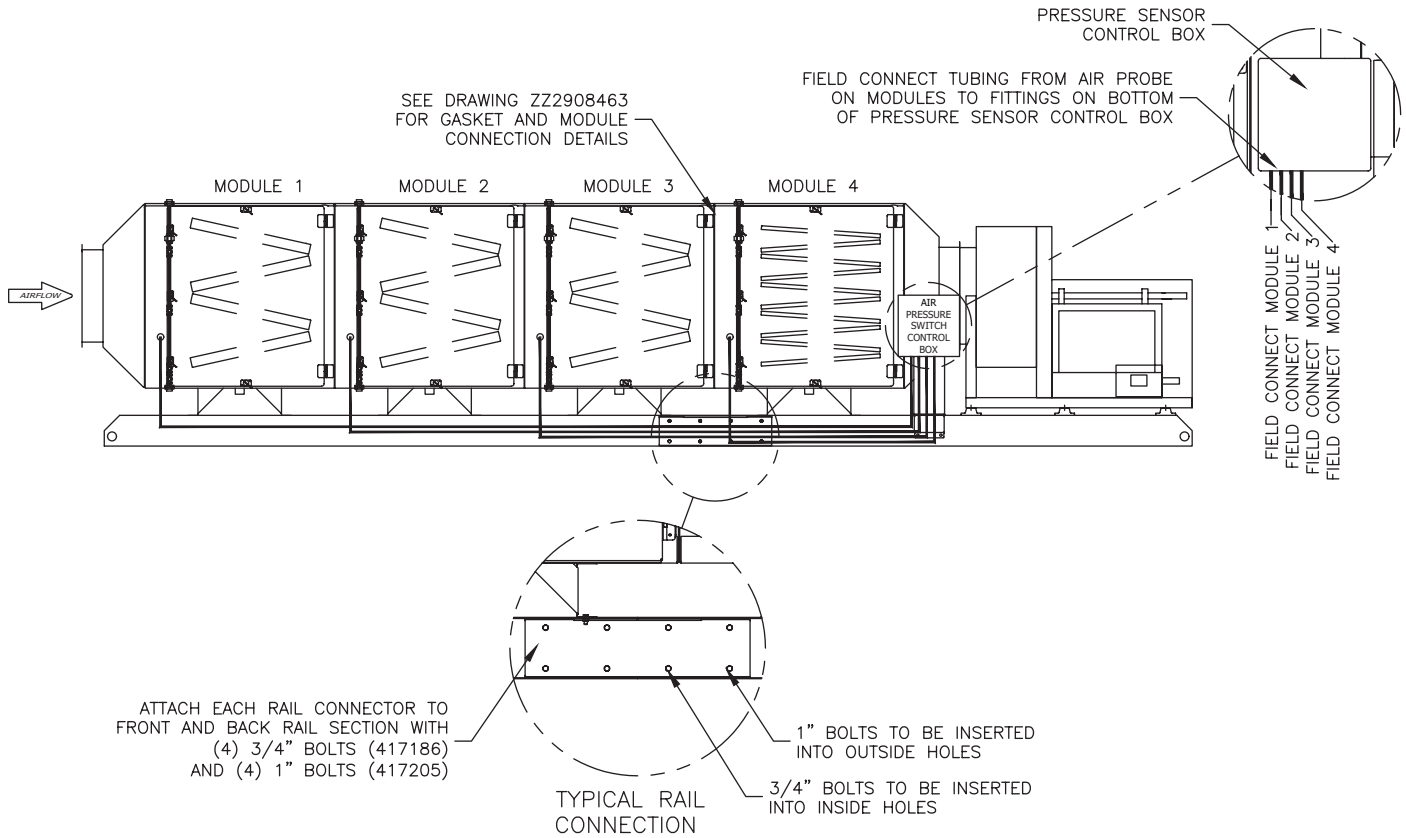

PCU Field Assembly - if applicable

NOTE

Doors will have to be opened and/or removed to access fasteners inside of modules.

- After rails and modules have been moved to desired location, the modules and rails can be reassembled. Install gasket to applicable cells as shown below.

MODULE FLANGE GASKETING DETAIL

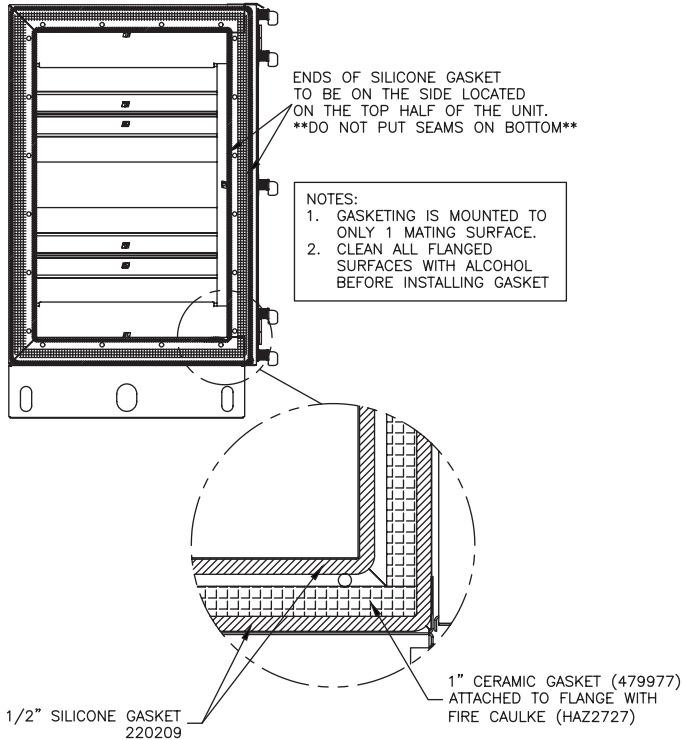

- Reattach the fasteners from step 2 as shown in the drawing below, ensuring proper gasket and seam cover installation.

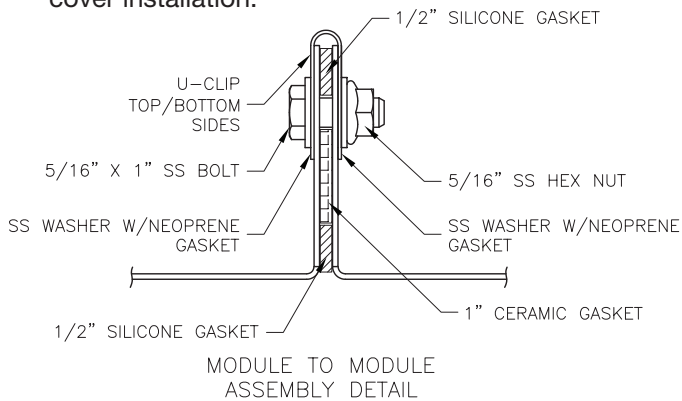

Attaching Fans

NOTE

For housing sizes 180 and 270, the unit and fan will always be mounted on separate rails.

The PCU fan is shipped bolted to unit body and rails. If the unit was requested to be disassembled in the field, the unit body-to-fan connection has not been sealed.

- To disassemble in the field, remove mechanical fasteners that attach the companion flange and fan to the unit body.
- Remove mechanical fasteners that attach the fan to the isolators on the rails.

After fan and unit body have been moved to desired location, the fan can be sealed and reattached to the unit body and rails.

- To seal the fan to unit body connection, apply fire rated caulk (3M Fire Barrier Sealant CP25WB+ or equivalent) to fan inlet flange. Make sure to apply caulk around each bolt hole. Caulk to be located outside of silicon gasket mounted during step 4.
- Attach 1/2 inch silicone gasket around fan inlet flange. Silicone gasket to be located inside of caulk applied in step 3 (seam of gasket to be located on the side of unit).

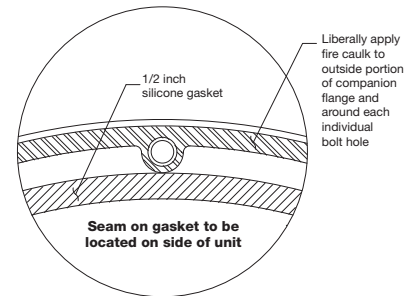

- To reassemble locate fan on isolators on rails.
- Reattach fasteners for companion flange removed in step 1.
- Reattach fasteners attaching fan to isolators removed in step 2.

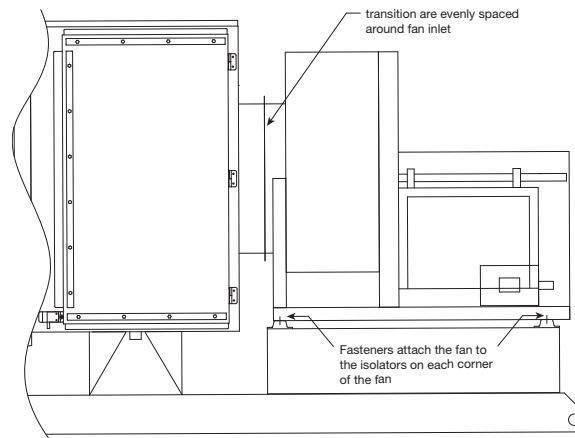
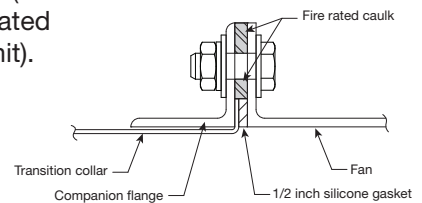

Installation

Rigging and Placing Equipment

1. The unit is furnished with lifting lugs at the four corners.
2. Use a crane and a set of spreader bars hooked to all four factory lifting lugs to lift the unit.

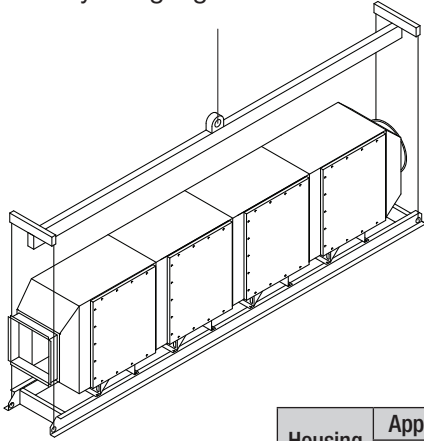

3. Field weight will vary depending upon final selections such as fan type, accessories, etc. Approximate weights (4 module unit with mounted utility set fan as basis) are shown in the table.
4. The unit can be positioned on a base or roof deck suitable for this purpose.
5. The unit must be anchored to its base/roof deck.
6. Alternatively, units from housing sizes 30 to 120 may be suspended from an adequate overhead structure, using suitable undercarriage or hanging rods (by others). If the unit is suspended by hanging rods, minimum 1/2 inch (12.7 mm) diameter threaded rod is to be used. All hanger brackets/lifting lugs must be used to ensure proper support of the unit. The unit must also be hung level to ensure proper operation.
7. A service clearance of 36 inches must be provided on the access door side of the unit.

Housing	Approximate Weight	
	lbs	kg
30	1232	559
45	1566	711
60	1953	886
90	2451	1112
120	2903	1317
180	4432	2011
270	5795	2629

NOTE

If unit is suspended using hanging rod, make sure rods do not interfere with opening/closing all module doors.

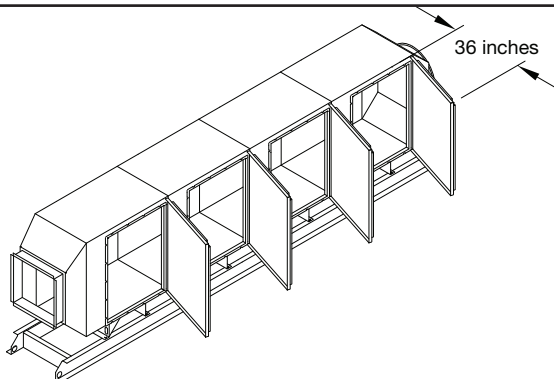

8. A minimum 12 inch clearance must be maintained between the top and 6 inches on each side and bottom of this unit and any combustible material.
 - Ensure the fan is located in an easily accessible area, of adequate size and clearance to allow for service or removal.
9. The Remote Filter Status Indicator Panel (see page 8 and 11) should be located in an area convenient for monitoring by the cook staff. For details on wiring this item, refer to the Wiring Diagrams on page 27.

Ductwork Connections

Ductwork must conform to the IMC and SMACNA guidelines.

All factory-built grease duct needs to be constructed in accordance with ANSI/UL 1978 and should be manufactured and installed in accordance with their listing. All field-built grease ductwork must be constructed in the following manner per NFPA 96, unless otherwise specified by the local authority having jurisdiction (AHJ):

Materials - Ducts shall be constructed of and supported by carbon steel not less than 1.37 mm (0.054 in.) (No. 16 MSG) in thickness or stainless steel not less than 1.09 mm (0.043 in.) (No. 18 MSG) in thickness.

Installation - All seams, joints, penetrations, and duct to hood collar connections shall have a liquid-tight external weld.

Units intended for indoor mounting have an outlet mounting flange provided on the outlet of the fan. Outlet ductwork from the exhaust fan is required to be per the above mentioned methods unless otherwise specified by the local authority having jurisdiction (AHJ).

Plumbing Connections

Each module is provided with a drain to allow any grease or washing solution to be removed from the unit. The drains must be connected to a grease receptacle ensure proper unit operation.

The units are provided with a 1-inch nipple from the factory located in the middle of each module to be used as a drain connection. The drains can be manifolded together and a ball valve is recommended on each module drain.

All plumbing components are provided by others and must be installed based on local plumbing codes.

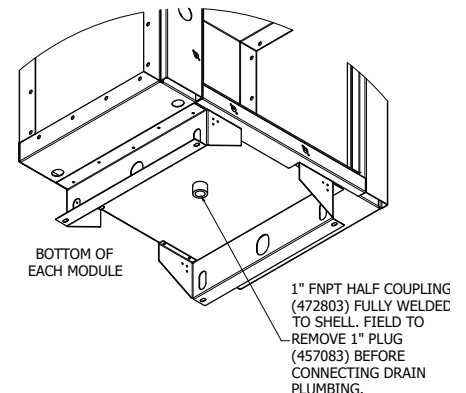

Installation

Remote Filter Status Indicator Panel (if provided)

Locate spot on the wall for Remote Filter Status Indicator panel and fasten to wall. See Electrical Connections sections for wiring details.

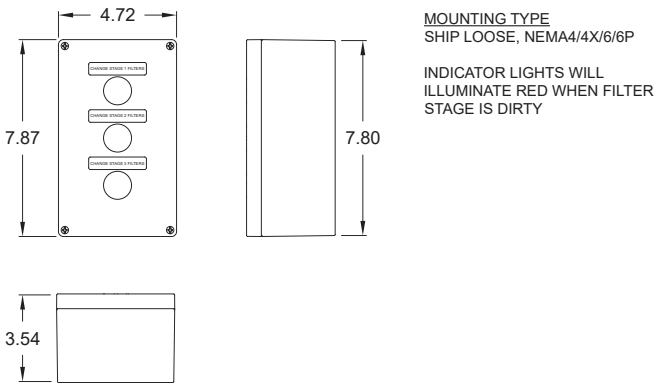

Filter Installation (see Figure 1 on page 23)

The mechanical filters are shipped in the unit (Metal Mesh, Standard Pleated, High Efficiency). The carbon filters are shipped loose, and are typically located on the end of the shipping pallet.

Care must be taken to ensure filters are installed in the proper sequence and proper direction of airflow.

Open the access doors. Slide filters into filter racks in stages 1, 2, 3 and 4. Close and secure access doors.

Description	Nominal Dimensions (inches)
MERV 2 Metal mesh frame filter	24 x 24 x 2
MERV 8 Standard pleated filter	24 x 24 x 2
MERV 15 High efficiency pleated filter	24 x 24 x 2
Pre-Filled Carbon Trays	24 x 24 x 1

System Control Panel (if provided and shipped loose)

Locate an area with enough space to mount the control box and fasten to the wall. See unit specific drawings for enclosure dimensions.

Ship Loose VFD (if provided)

Locate an area near the unit with enough space to mount the VFD and fasten to the wall. Follow VFD IOM provided with the VFD for more detailed mounting instructions.

Keypad Mounting (if provided)

NOTE

The keypad may be factory mounted. If so, continue to the Electrical Connections section.

- For systems with remote controls or keypad, a 35, 75, or 150 foot RJ25 cable is supplied to connect the keypad to the controls. The cable is plenum rated and does not need to be run through conduit unless required by local codes. If the keypad is to be mounted further away than the cable that is received, additional cable will be needed. Additional cable is available at the lengths mentioned above.

Keypad Mounting Diagram

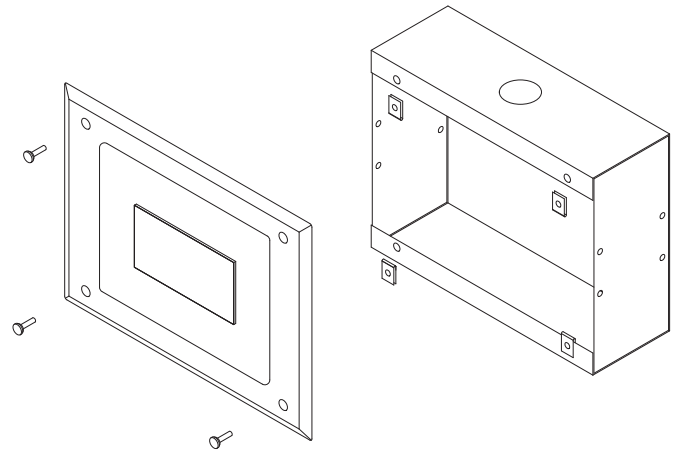

Keypad Dimensions

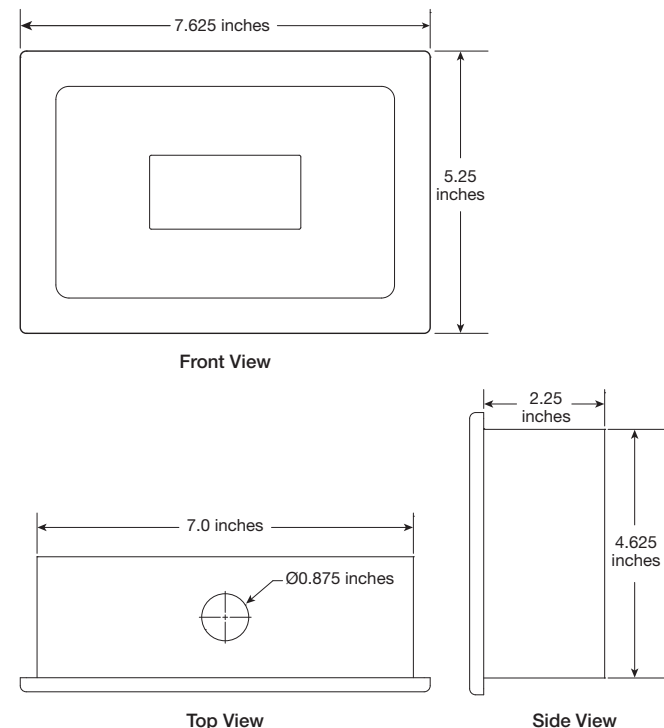

Installation

Electrical Connections

Once all system components are installed, electrical connections for the system can be made.

CAUTION

RISK OF ELECTRIC SHOCK. All wiring to be done by qualified personnel only.

NOTE

All wiring must be done according to the equipment data plate information, NEC (National Electrical Code NFPA 70), and local codes.

NOTE

Under no circumstances should extension cords be used to connect the source of electrical supply to the equipment.

NOTE

An earth ground must be provided to the main control panel (if provided).

The Grease Trapper Filtered PCU will require additional field wiring for proper installation. If configured with a main control panel, it will be shipped loose or mounted on the unit rails and is designed for either indoor or outdoor applications. A typical field wiring schematic is shown on page 25. Refer to the unit specific wiring diagram located on the inside of the door of the system control panel for the unit specific wiring that is required.

In some cases, no system control panel will be provided, and instead the Remote Filter Status Indicator Panel will be provided. For wiring details for Remote Filter Status Indicator Panel, refer to diagram on page 27.

Wiring from fan disconnect to fan motor will be done by the factory if the disconnect switch is mounted to the fan or to the unit.

Wiring from the output of the VFD to the fan disconnect switch will be done by the factory if the VFD is mounted inside the system control panel, and the system control panel is mounted on the unit rails.

If the fire system cabinet(s) are provided with a cabinet heater, separate single phase power is required to be operate to the cabinet heater controls.

Installation

Fire System

The Pollution Control Unit (PCU) is furnished with factory pre-piped fire suppression nozzles. Field connection, tanks, controls, fusible link detectors, and commissioning is provided and installed, based on specifications at time of order. The AHJ may require additional protection.

The PCU may be provided with one or more cabinets, shipped loose for field install, containing the fire suppression components. If a fire cabinet(s) are provided, locate an area as close to the PCU as possible (within 5 feet from the PCU), with enough space to mount the fire cabinet(s), and fasten to wall. If provided with indoor cabinet(s), fasten to wall using 1/4" holes located along all four sides of the back wall of the cabinet. If provided with outdoor (NEMA4) cabinet(s), fasten to wall using 5/16" bolts at the four (4) holes located 3/4" offset from the corners of the back face of each cabinet. Size and type of fastener are the responsibility of installer. Ensure 36" of horizontal clearance in front of the cabinet(s) for access and code compliance. Ensure sufficient clearance above cabinet(s) for fire system piping to the PCU. Cabinet(s) may be provided with heater if mounted outdoors, refer to Fire System Cabinet Wiring Outdoor for details. Cabinet dimensions and quantity will vary based on the PCU size and mounting location (Indoor/Outdoor); see image and table for reference. Refer to unit fire drawings for final cabinet dimension and quantity.

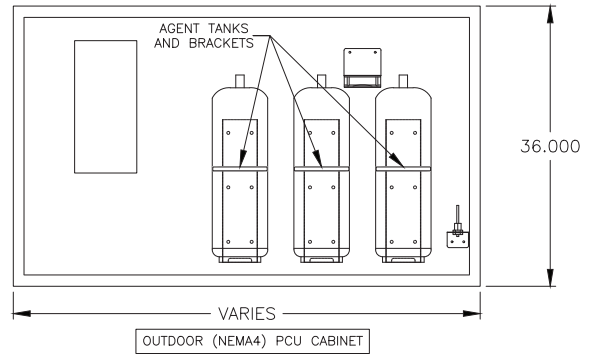
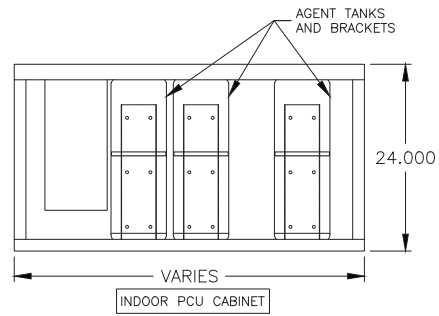

PCU Fire Cabinet Quantity and Size		
Housing Size	Indoor Cabinet	Outdoor (NEMA4) Cabinet
30	See Drawings	(1) 42"
45	See Drawings	(1) 60"
60	See Drawings	(1) 60"
90	See Drawings	(1) 60"
120	See Drawings	See Drawings
180	See Drawings	See Drawings
270	See Drawings	See Drawings

ANSUL

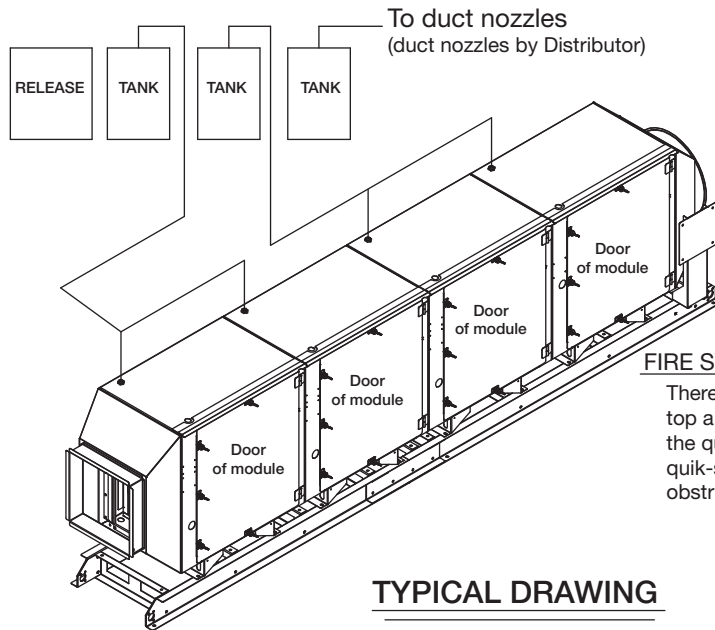

FIRE SYSTEM DISTRIBUTOR / FIRE SYSTEM INSTALLER:

There are four quik-seals on each module. Two are on the top and two are on the bottom. Connection to only one of the quik-seals on each module is required. Multiple quik-seals are provided for situations where there are obstructions to the connection point.

- Do not install fire piping in front of doors on module. Must have 36 inches of clearance.
- Do not install fire piping such that it interferes with the drain plugs & piping on the bottom of the modules.

Operation

NOTE

Prior to starting the fan, remove fan tie down straps. These are used only to prevent shipping damage. After removing the tie down straps, the fan should float freely on the isolators. Confirm that the installation is completed as shown in the Installation section.

Initial System Start-Up

1. Verify unit is installed properly and all plumbing and electrical connections have been made.
2. Close and properly fasten the doors on the unit.
3. Turn on electrical power to control cabinet (if provided) and exhaust fan.
4. Turn on fan disconnect.
5. Turn the fan on momentarily, then turn off. If a fan button exists on the user interface, press the button to start the fan. If a fan button does not exist on the user interface, or the unit wasn't configured with a user interface, the fan will need to be turned on by external means. Remove fan drive access cover and verify proper fan wheel rotation. If rotation is backwards, reverse the fan motor electrical input leads.
6. If provided with a system controller, check for alarms on the controller. Correct any alarms that may be displayed (see page 13 for details).
7. System should now be ready for operation.

Remote Filter Status Indicator *(if provided)*

As the mechanical filters load with grease particles, resistance to airflow increases and the exhaust air volume decreases.

Pressure switches continuously read the resistance across each filter stage. Each pressure switch is factory preset to transmit an alarm signal when that stage of filter has reached its terminal resistance and needs replacing with new filters. This terminal resistance setting is based on the filter manufacturers rating. The alarm signal illuminates an indicator light located on the face panel of the Remote Filter Status Indicator Panel (if provided).

Unit Size	Resistance Setting
30-120	0.5
180-270	0.2

IMPORTANT

Replace filters immediately if Remote Filter Status Indicator indicates a filter is loaded, or if provided with keypad and Dirty Filter Alarm fault is present, or if BMS is triggered that a filter is loaded. Failure to do so may cause reduced exhaust air volume allowing smoke to escape into the kitchen, or may cause filters to rupture, or both. The terminal resistance for each stage of filters is factory set. Altering these settings without first contacting Greenheck will void the manufacturer's warranty.

Filter Replacement

Determine which stage(s) of filter needs replacing as shown by either Remote Filter Status Indicator Panel, or fault on Keypad, or via BMS integration.

1. Have the correct type and quantity of filters available at the unit.
2. Turn off and lockout power to the fan.
3. Open the appropriate access door(s).
4. Remove the spent filter(s) by sliding them out of the housing access door opening.
5. Replace with the proper new filter(s) making sure direction of airflow is correct.
6. Close and secure access door(s).
7. Turn on power to the fan.
8. Proper filter disposal is important to the environment. Refer to local landfill codes.

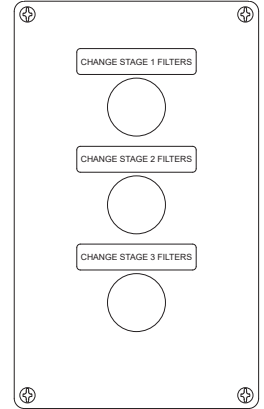

Remote Filter Status Indicator Panel

Carbon Tray Replacement



Unlike particulate filters, technology has yet to develop a cost-friendly method of determining when the carbon trays need replacing. So, the industry standard is the human sniff test. As the carbon begins to lose its effectiveness, odor breakthrough gradually occurs and odor concentration increases. Based on a variety of cooking applications/installations, life of the carbon trays can range from a few months to one year. Replace carbon trays when odor breakthrough is first noticed. When replacing carbon trays, follow the instructions in the Operation section, Filter Replacement, Steps 2 thru 8.

Controller Setup and Tutorial - if provided with System Control Panel







The user can access the main menu by pressing the  button.

Within the programmable logic controller, factory set points can be modified to configure the system for specific functions if necessary. All parameters are shown in this section.





Some of the menus require the user to enter a password in order to enter the menu. The service password is 1000 and is entered by pressing the   to change the number and to advance the cursor, press the  button.

The DDC controller is located in the unit control panel. The face of the controller has six buttons, allowing the user to view unit conditions and alter parameters. The DDC controller is pre-programmed with easy to use menus.

To change the display contrast, hold the Alarm  and Program  buttons simultaneously while pressing the  and  arrows.

If equipped, the keypad user interface connects via a factory-provided RJ-25 cable to the J10 port on the controller.

Information regarding most of the settings within the Controller U1 are provided in this Installation, Operation and Maintenance Manual.



Keypad Navigation		
	Escape	Allows the user to exit the current menu, jumping to the Main Menu.
	Up Down	The arrow buttons allow the user to scroll through different screens and adjust parameters.
	Alarm	Button will blink red, indicating an alarm condition. Press to review current alarms. To review previous alarms, access the DATA LOGGER in the alarm menu.
	Enter	A. In screens with adjustable parameters, pressing the Enter button moves the cursor from the upper left corner of the screen to the parameter. The arrow buttons can then be used to adjust the parameter. B. To move to the next parameter on the same screen, press the Enter button. C. To save the change, press the Enter button until the cursor moves back to the upper left corner of the screen.
	Program	Pressing the Program button allows the user to enter the Main Program Menu.

Example of Parameter Adjustment

Exhaust 1 Setpoints		
	Temp	Speed
Low:	90.0°F	50.0%
High:	115.0°F	100.0%
Current Temp:	70.0°F	

Once you enter into a menu that has adjustable parameters, the cursor always begins in the upper left corner of the display and will be blinking. Press the  button to move the cursor down for parameter adjustment.

Exhaust 1 Setpoints		
	Temp	Speed
Low:	90.0°F	50.0%
High:	115.0°F	100.0%
Current Temp:	70.0°F	



Once the cursor has reached the desired parameter, press the   buttons to adjust the value.



Exhaust 1 Setpoints		
	Temp	Speed
Low:	90.0°F	50.0%
High:	115.0°F	100.0%
Current Temp:	70.0°F	

When satisfied with the adjustment, press the  button to save the parameter. **When finished, make certain the cursor is in the upper left corner. If the cursor is not in the upper left corner, the changes will not be saved.** The cursor must be in the upper left corner to enable screen advancement.



Main Menu Overview

Pressing  button will bring you into the main menu. Scrolling up/down with   buttons will bring you to different sub-menus including **A: Clock, B: Input/Output, C: Service, and D: Manufacturer.**

Exiting the main menu (using  button) this will first bring you to system status screen loop. This loop includes several screens to view the operating conditions of the unit. Scroll through the menu screens by using   buttons. **Screens with dashed line border are dependent upon the configuration and may not appear for every system.**

PCU Exhaust Fan Status	
Exhaust:	Off
Speed:	0.0%

PCU EXHAUST FAN STATUS:

This screen will display the status of the PCU exhaust fan as well as display the fan speed (if applicable).

Fan Enable Status	
Fan ON by DI:	Off
Fan ON by Fire:	Off
Fan ON by BMS:	Off
Fan ON by Bal:	Off
Fan ON by BTN:	Off

PCU FAN ENABLE STATUS:

This screen will display what is currently responsible for turning the exhaust fan on.

Filter Module Status	
Filter Module 1:	OK
Filter Module 2:	Dirty
Filter Module 3:	OK
Filter Module 4:	OK
Filter Module 5:	OK



PCU FILTER MODULE STATUS:

This screen will display current status of each filter module present on the unit (whether filters are okay, or dirty and need to be replaced). Filter module status is provided for all non-carbon (odor) modules present on the unit.

Example of Alarms

If an alarm occurs, the  button will flash red on the controller and the keypad (if connected).

Alarms
Press DOWN to review current alarm(s).
Press ESC to exit.
Press ALARM to reset.

To navigate to the alarm menu, press the  button once. Press the  button to scroll through any current alarms. Once the problem causing the alarm has been corrected, all alarms except “Wash Aborted” alarm will automatically clear. Pressing the  button will clear the low detergent fault if it needs to be manually cleared. If the alarm cannot be cleared, the cause of the alarm has not been fixed.

*** ALARM ***
Exhaust Fan Alarm
Check exhaust starter or VFD for fault code.

This is an example of an exhaust fan fault.

Alarms
No active alarm
 Press ENTER key to access ALARM HISTORY log.

This screen appears if there are no active alarms.

To view all saved alarms, press the  button to enter the DATA LOGGER. For more information, see the Data Logger menu.

Alarm	Alarm Description
Dirty Filter Module Fault	Filter module section(s) has/have dirty filters that need to be replaced.
Exhaust Fan Fault	Failure of the exhaust fan
Fire Detected	Indicates fire in either the kitchen or PCU unit

Controller Setup and Tutorial - if provided with System Control Panel

A. Clock

The **Clock** menu allows the user to view and alter the time and date. The user can also adjust the daylight savings time setting.

Clock	
02:00:00PM	04/11/25
Date:	04/11/25
Hour:	2:00pm
Day:	Friday

THE CLOCK SCREEN ALLOWS THE USER TO ADJUST THE TIME AND DATE.

The time/date will not be adjustable on the controller if the user interface is the touch screen.

Clock	
DST:	Enable
Transition time:	60min
Start:	LAST SUNDAY
in MARCH	at 2.00
End:	LAST SUNDAY
in OCTOBER	at 3.00

THIS SCREEN ALLOWS THE USER TO ADJUST DAYLIGHT SAVINGS TIME SETTING.

The Daylight Savings time feature can be adjusted to meet the current daylight savings time requirements.

Holiday Configuration	
Number:	4
Wash and fan schedules will not operate during holidays.	

THIS SCREEN ALLOWS THE USER TO ADD AND ADJUST HOLIDAY TIMES.

The user can add up to 16 holidays. Adding holidays will prevent the wash and fan scheduler controlling the wash/fan during the days selected.

Holiday X	
1:	0/ 0 - 0/ 0
2:	0/ 0 - 0/ 0
3:	0/ 0 - 0/ 0
4:	0/ 0 - 0/ 0

B. Input/Output

The **Input/Output** menu allows the user to quickly view the status of the controller inputs and outputs.

Analog Input	
Fan Speed (AIN1)	
Input B001:	0.0%

To manually control I/O values, go to the **Service menu > Service settings > I/O Manual Control**.

Similar screens appear for all controller inputs and outputs.

Your controller may not utilize the input shown. See unit wiring diagram for your specific configuration.

Digital Input	
On / Off (DIN1)	
DI 1 Status:	Open

Similar screens appear for all controller inputs and outputs.

Your controller may not utilize the input shown. See unit wiring diagram for your specific configuration.

Relay Output	
Exhaust Relay (DOU1)	
Relay 1 Status:	OFF

Similar screens appear for all controller inputs and outputs.

Your controller may not utilize the output shown. See unit wiring diagram for your specific configuration.

Analog Output	
Fan Speed (AOUT1)	
Output:	5.00vdc

Similar screens appear for all controller inputs and outputs.

Your controller may not utilize the output shown. See unit wiring diagram for your specific configuration.

Controller Setup and Tutorial - if provided with System Control Panel

C. Service

The **Service** menu allows the user to access several sub-menus regarding controller information, controller overrides, operating hours, BMS configuration, I/O manual management . By accessing the **BMS Configuration** sub-menu, the user can adjust BMS protocol settings. (BACnet®, Modbus)

C. Service

a. System Information

Information	
Greenheck Fan Corp.	
Version:	1.00.001
Date	04/11/2025
Bios:	6.40 11/17/15
Boot:	5.02 09/30/13

The **System Information** sub-menu displays information about the controller and the program loaded on the controller.

THIS SCREEN SHOWS VERSION, BOOT AND BIOS INFORMATION. BIOS AND BOOT PERTAIN TO THE CONTROLLER'S FIRMWARE AND OPERATING SYSTEM.

C. Service

b. BMS Configuration

BMS Configuration	
Protocol::	BACnet MSTP
To adjust BACNET settings press & hold ALARM & ENTER keys to access BIOS screens.	

The **BMS Configuration** sub-menu allows the user to view and alter BMS protocol settings. If the BMS protocol is BACnet or Modbus, additional screens allow further configuration. See below for details. To access the **BMS Configuration** sub-menu, enter the service password (Default=1000).

THIS SCREEN ALLOWS THE USER TO SELECT THE BMS PROTOCOL. ALL BMS PROTOCOLS REQUIRE A COMMUNICATIONS CARD INSTALLED IN THE SERIAL CARD PORT, LOCATED ON THE FACE OF THE CONTROLLER.

If the protocol is BACnet MSTP or BACnet IP/Eth, the user must enter into the operating systems (BIOS) screens to adjust BACnet parameters.

MODBUS SETUP	
BMS Card	
Address:	1
Baudrate	19200





THIS SCREEN ALLOWS THE USER TO ADJUST MODBUS PARAMETERS.

This screen only appears if the selected BMS protocol is set to Modbus.

The address is the Modbus address of the card installed in the SERIAL CARD port located on the face of the controller. (Factory Default = 1).

The Baud Rate should be set to the BMS baud rate. (Factory Default = 19200).

TO ACCESS/ADJUST BACNET MSTP AND IP PARAMETERS, PERFORM THE FOLLOWING STEPS...

1. Press together for 3 seconds the  (alarm) and  (enter) to enter the BIOS menu. Press  (down) arrow to select OTHER INFORMATION and press  (enter) to confirm.

SYSTEM INFORMATION
LOG DATA
>OTHER INFORMATION
FLASH/USB MEMORY

2. Press  (down) arrow to select PCOWEB/NET CONFIG and press  (enter) to confirm.

ID/PRODUCT CODE
>PCOWEB/NET CONFIG
MEMORIES STATUS
CHIP IO VERSION

3. Select either PCOWEB Settings for BACnet IP or PCONET Settings for BACnet MSTP and press  (enter) to confirm.

>PCOWEB settings
>PCONET settings



Controller Setup and Tutorial - if provided with System Control Panel

4. Once reaching the PCO Settings, adjust each BMS parameters and press enter to cycle through them all. Once finished adjusting all the parameters, be sure to have save the parameters by navigating to the screen that shows “PCONET CONFIG ENABLE” and changing “NO” to “YES” next to “Update pCOnet?”. Then follow the prompts on the screen to cycle power on the controller.

Make sure to cycle power when prompted to cycle power to the controller by unplugging the G/GO orange plug on the bottom of the controller, then plugging it back in. Skipping this step will not save parameters that were adjusted.

BACNET IP

DHCP: **OFF** (off = static)
 IP Address:
--0. --0. --0. --0

Netmask: (subnet)
--0. --0. --0. --0
 Gateway:
--0. --0. --0. --0

DNS1:
--0. --0. --0. --0
 DNS2:
--0. --0. --0. --0

BACnet ID: (instance)
77000
 BACnet Type:
IP or **Ethernet**

PCONET CONFIG ENABLE
 UPDATE pCOWeb? **YES**

BACNET MSTP

BACnet ID: (instance)
77000
 BACnet baud:
38400

BACnet MAC: **127**
 Max Masters: **--0**
 Max Frames: **--20**

PCONET CONFIG ENABLE
 UPDATE PCOWeb? **YES**

C. Service

- c. Service Settings 
- a. Fan Operation
- b. I/O Manual Control
- c. Sensor Calibration
- d. User Save/Restore
- e. Alarm History Reset

The **Service Settings** sub-menu allows the user to adjust fan operation settings, set a fan on/off schedule, manually enable/disable input and outputs, calibrate sensors, create or restore user settings and the alarm history log.

C. Service

- c. Service Settings
- a. Fan Operation

The **Fan Operation** sub-menu allows the user to adjust fan settings.

Auto Fan Off Settings

Auto Fan Off? No
 Run Hours: 8 hours
 Note: This will only shut the fan off if the fan was powered on by the keypad (NOT DI)

THIS SCREEN ALLOWS THE USER TO ADJUST SETTINGS REGARDING THE AUTO OFF FEATURE WHICH STOPS THE FAN IF STARTED FROM THE USER INTERFACE AFTER A SPECIFIC AMOUNT OF TIME.

Auto Fan Off?: Enable or disable the auto fan off feature. (Default is No).

Run Hours: Adjust fan run time before the fan automatically shuts off. (Default = 8 hours).

Controller Setup and Tutorial - if provided with System Control Panel

Fan Scheduling						
Fan On:	NO 8:00am					
Fan Off:	NO 10:00pm					
Days/Week						
Mo	Tu	Wd	Th	Fr	Sa	Su
■	■	□	■	■	■	■

C.  Service	
c. Service Settings	
b. I/O Manual Control	

Analog Input	
Fan Speed (AIN 1)	
Manual Control	B001:OFF
Manual Position	0.0
Value	100.0

Digital Input	
On / Off (DIN 1)	
Manual DI 1:	OFF
Manual Position:	CLOSED
DI 1 Status:	Open

Relay Output	
Exhaust Relay (DOU 1)	
Manual Relay 1:	OFF
Manual Position	OFF
Relay 1 Status:	OFF

Analog Output 1	
Fan Speed (AOUT 1)	
Mode:	Auto
Manual Value	0.00vdc
Output:	0.00vdc

C.  Service	
c. Service Settings	
c. Sensor Calibration	

Analog Input	
Fan Speed (AIN1)	
Input B01	
Offset	0.0
Value	100.0

THIS SCREEN ALLOWS THE USER TO SET A FAN ON/OFF SCHEDULE FOR THE WEEK.

Fan On: Enable or disable the fan turning on at a specific time. Time can be adjusted below for fan on setting. (Default is NO, with 8:00am start time).

Fan Off: Enable or disable the fan turning off at a specific time. Time can be adjusted below for fan off setting. (Default is NO, with 10:00pm start time).

Days/Week: Adjust which days per week the auto wash should occur. Black (filled in) boxes indicate enabled for that day, white (open) boxes indicate disabled for that day.

IN I/O MANUAL CONTROL, THE USER WILL BE ABLE TO ADJUST INPUTS/OUTPUTS.

NOTE: The manual adjustment of these input and/or outputs should only be adjusted in the event of troubleshooting. We suggest these parameters only be changed with the advice of factory personnel.

Manual Control: Allows the user to override the analog input for troubleshooting.

Manual Position: The value to force the input to when in an override state.

Value: The current value of the analog input.

Manual DI: Allows the user to override the digital input for troubleshooting.

Manual Position: The value to force the input to when in an override state.

Status: The current value of the digital input.

Manual Relay: Allows the user to override the relay output for troubleshooting.

Manual Position: The value to force the output to when in an override state.

Status: The current value of the relay output.

Mode: Allows the user to override the analog output for troubleshooting.

Manual Value: The value to force the output to when in an override state.

Output: The current value of the analog output.

IN SENSOR CALIBRATION, THE USER WILL BE ABLE TO ADJUST ANALOG INPUTS OFFSETS.

Offset: This adjustable value can be used to calibrate the input with an offset value. (Factory Default = 0.0)

Value: This is the current value of the input. (Offset adjustment is added).

Similar screens are available for the remaining analog inputs.

Controller Setup and Tutorial - if provided with System Control Panel

C. Service

- c. Service Settings
- d. User Save/Restore

User Save/Restore



Save?	No
Restore?	No
Enable Auto Save:	Yes

IN USER SAVE/RESTORE MODE, THE USER WILL BE ABLE TO SAVE AND RESTORE THE DEFAULT PARAMETERS STORED IN MEMORY.

If the user would like to save their settings, move the cursor to the SAVE position and change to YES. This will save all of the current parameters into memory as Service Settings. If the user would like to restore to these values at some point in the future, moving the cursor to the RESTORE position and selecting ON, will restore the controller to the user-saved defaults.

C. Service

- c. Service Settings
- e. Alarm History Reset

Alarm History Reset

This will clear the alarm history.

Continue? NO

THIS SCREEN ALLOWS THE USER TO CLEAR THE ALARM FROM MEMORY.

If the user would like to clear the alarm log, move the cursor to the OFF position and change to YES.

D. Manufacturer

The **Manufacturer** menu allows the user to access several sub-menus regarding controller configuration, I/O configuration, factory settings, controller initialization pages, and factory save/restore pages. These changes are to be completed under factory advisement only!



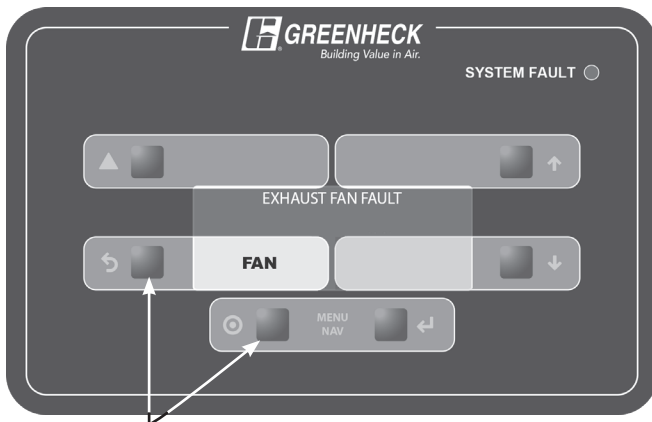

Keypad Navigation



When '**BUTTON(S)**' are mentioned in the description below, we are referring to the 'squares' on the keypad. The following information details the Daily Operations of the Grease Trapper Filtered PCU keypad buttons and their functions.

FAN - Momentarily pressing the 'FAN' button will turn on the PCU unit. If the fan is on, the background behind 'FAN' text will be dark. To turn the system off, press the 'FAN' button.

Display functionality and control:

To change the display contrast, hold the buttons next to the Alarm  and Program  icons simultaneously while pressing the buttons next to the  and  arrows. The down arrow will make the screen lighter and the up arrow will make the screen darker.

Upon any alarm, the 'SYSTEM FAULT' red LED light on the face of the keypad starts flashing. Once all alarms are corrected and any low detergent alarm is manually reset, this LED will stop flashing and no longer be illuminated.

Through the middle of the screen, system status messages will be displayed as a reference. These system statuses will include:

- Current alarms
- Exhaust Fan Status

The keypad also includes indicators next to the buttons that correspond to the buttons on the controller. These can be used to navigate through the controller using the keypad. To access the main menu, simply press and hold the button next to the Program  icon for **five seconds** or until the screen changes to the main menu.

Variable Frequency Drive (VFD) Information

A Yaskawa V1000 (200-230 and 460 VAC, 25HP or lower) or Yaskawa A1000 (575 VAC) or HV600 (30HP or larger) variable frequency drives (VFDs) will be provided if the PCU is configured to use a VFD to control the exhaust fans. These drives will come programmed from the factory, and little to no adjustment will be necessary in most cases. For more in-depth information on wiring and programming these drives, please utilize the Quick Start Guide provided with the package. This quick start guide and other technical manuals can also be found on the Yaskawa website at www.yaskawa.com.



Parameter	Description	Default Value	Factory Adjustment
b1-07	LOCAL/REMOTE Run Selection	00	01
b1-17	Run Command at Power Up	00	01
C1-01	Acceleration Time 1	10.00 seconds	30.00 seconds
C1-02	Deceleration Time 1	10.00 seconds	30.00 seconds
E1-01	Input Voltage	Dependent on drive type	Dependent on motor voltage*
E2-01	Motor Rated Current	Dependent on drive type	Dependent on motor FLA (full load amperage)*
L2-01	Momentary Power Loss Operation Selection	00	02
L5-01	Number of Auto Restart Attempts	00	10

*See PCU wiring diagram for more information.

Resetting the VFD Faults

Upon a VFD fault, first determine the cause of the fault and correct. Typically, if the drive detects a fault, it will remain inoperable until that fault has been corrected and the drive has been reset.

Once a fault has been corrected, the easiest way to clear the displayed fault on the VFD is to shut off power to the drive from the power source (breaker). Wait for the VFD to fully discharge and then restore the power.

Upon correcting a minor fault, recycling power may not be necessary. Simply press , then press  twice.

Model V1000

Changing Parameters

Step 1: V1000 Digital Operator power-up state.

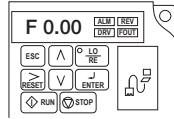

Step 2: Select Parameter Menu

Press **[V]** two times until the digital operator show the parameter menu (PAR) then press **[ENTER]**.

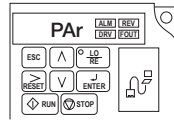

Step 3: Select Parameter

Press **[RESET]** to select the digit you would like to change. Next use **[^]** and **[V]** to select the parameter group, sub-group or number.

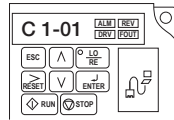

Once the parameter you wish to change is displayed on the screen and the digit furthest to the right is flashing, press **[ENTER]**.

Step 4: Change Parameter Value

Press **[RESET]** to select the digit of the parameter value you would like to change.

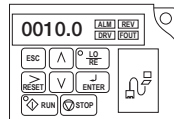

Modify the parameter value using **[^]** and **[V]** and press **[ENTER]** to save the new value.

Model A1000

Changing Parameters

Step 1: A1000 Digital Operator power-up state.

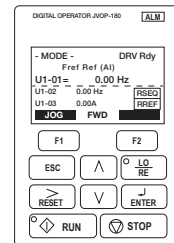

Step 2: Select Parameter Menu

Press **[V]** two times until the digital operator shows the programming menu, then press **[ENTER]**.

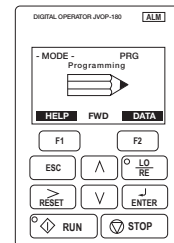

Step 3: Select Parameter

Press **[RESET]** to select the digit you would like to change. Next use **[^]** and **[V]** to select the parameter group, sub-group or number.

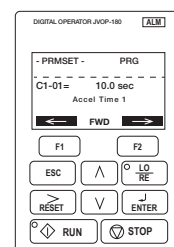

One the parameter you wish to change is displayed on the screen and the digit furthest to the right is flashing, press **[ENTER]**.

Monitor Motor Frequency and Motor Current

Step 1: V1000 Digital Operator power-up state:

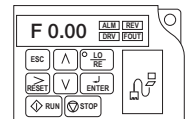

Step 2: Output Frequency

Press **[^]** until the **FOUT** LED turns on. The display now shows the actual drive output frequency in hertz (Hz).

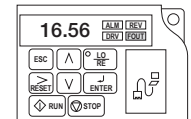

Step 3: Motor Current

Press **[^]** again will show the motor output current. The 'A' behind the value means 'Amps'.

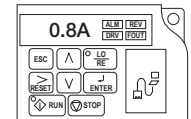

Step 4: Change Parameter Value

Press **[RESET]** to select the digit of the parameter value you would like to change.

Modify the parameter value using **[^]** and **[V]** and press **[ENTER]** to save the new value.

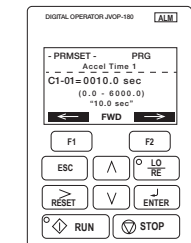

Monitor Motor Frequency and Motor Current

With the drive running, press **[^]** until reaching the Monitor Menu. This will display output frequency and amperage of the motor.

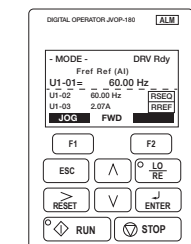

Grease Trapper Filtered v1.00 Modbus / BACnet® Points List

Type	BACnet Device Instance: 77000 (default) Analog = AV, Integer = AV, Digital = BV				Modbus - RTU/TCP Address: 1 (default)	Read Write	Description
	Instance	Name	Units				
Analog	1	BMS_Exhaust_Speed	percent		40001	R	BMS Exhaust Fan Speed Percentage
Analog	1	Exhaust_Speed	percent		40002	R/W	Exhaust Fan Speed Percentage
			Inactive Text	Active Text			
Digital	1	Remote_Enable	Off	On	10102	R/W	Remote Fan Enable (0: Off; 1: On)
Digital	2	Fire_Status	Off	On	10103	R	Fire System Status (0: Ok; 1: Fire)
Digital	3	Exhaust_Fan_Fault	Off	On	10106	R	Exhaust Fan Fault
Digital	4	Filter_mod_fault_1	Off	On	10107	R	Filter Module 1 Status (0: Ok, 1: Dirty)
Digital	5	Filter_mod_fault_2	Off	On	10108	R	Filter Module 1 Status (0: Ok, 2: Dirty)
Digital	6	Filter_mod_fault_3	Off	On	10109	R	Filter Module 1 Status (0: Ok, 3: Dirty)
Digital	7	Filter_mod_fault_4	Off	On	10132	R	Filter Module 1 Status (0: Ok, 4: Dirty)
Digital	8	Filter_mod_fault_5	Off	On	10133	R	Filter Module 1 Status (0: Ok, 5: Dirty)
Digital	9	Exhaust_relay_1	Off	On	10134	R	Exhaust Fan Status (0: Off, 1: On)
Digital	10	GLOBAL_ALARM	Off	Alarm	10138	R	Global Alarm

Maintenance

Regular Scheduled Maintenance

1. Replace filter(s) immediately after the Remote Filter Status Indicator lights up.
2. Replace carbon trays at the first sign of odor breakthrough.
3. Remove all filters and carbon trays and pressure wash/clean the housing interior as needed or as dictated by local code. Only use degreasers that are compatible with stainless steel surfaces. Use caution so as to not damage static pressure tips, tubing or fire system nozzles and detectors. Verify drain connections on are not clogged. Dry the housing interior and replace Stage 1 thru 4 filters, close and secure access doors.
4. Remove/open fan scroll access door and pressure wash/clean all internal surfaces of the fan every 6 months. Check sheave-belt alignment and belt tightness.
5. If provided with a fan, refer to the utility set or inline fan Installation, Operation and Maintenance (IOM) manual provided with unit for maintenance requirements.

Replacement Filter - Parts Ordering

Replacement filters and carbon panels can be obtained through the Greenheck Parts 800-371-6858 or your local authorized Greenheck Sales Representative.

Description	Part Number
MERV 2 Metal mesh frame filter	479981
MERV 8 Standard pleated filter	1009615
MERV 15 High efficiency pleated filter	479980
Pre-Filled Carbon Trays	484411

Unit Layout - Elevation Views

NOTE

Unit layout views are typical. Filter pass quantity and type vary based on the unit configuration. Reference actual unit drawings for unit specific details.

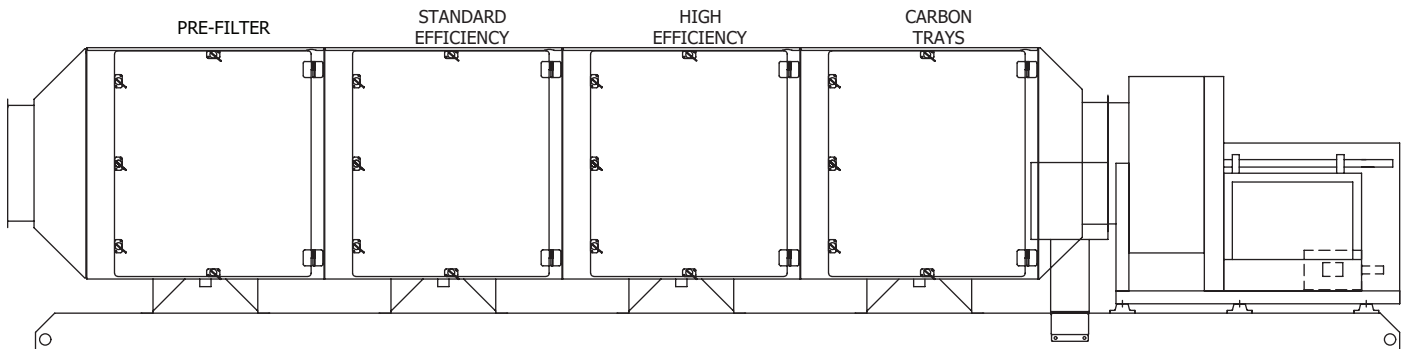

FIGURE #1: ACCESS DOOR SIDE

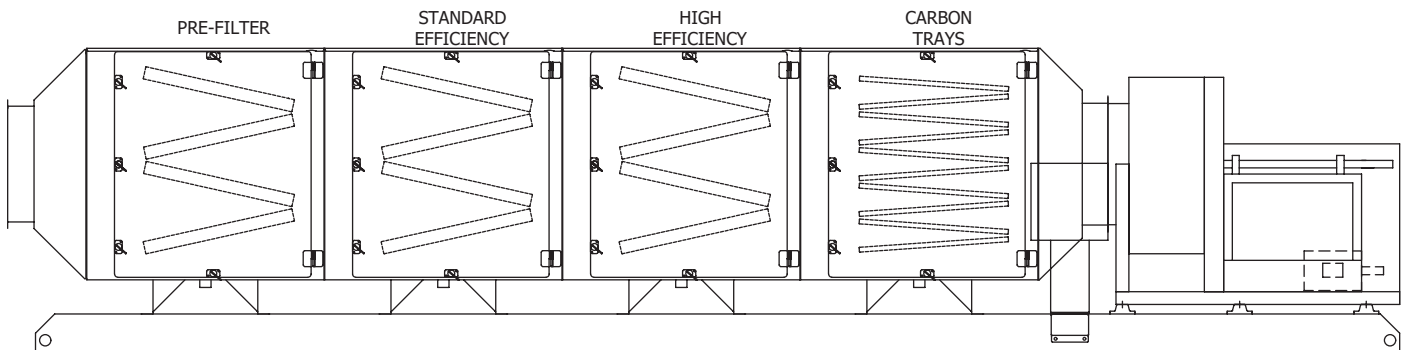

FIGURE #2: ACCESS DOORS REMOVED

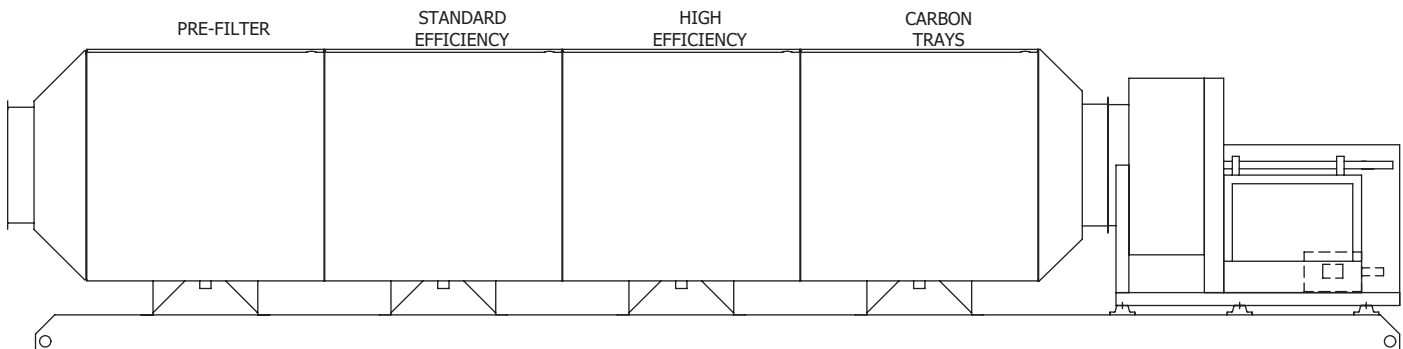
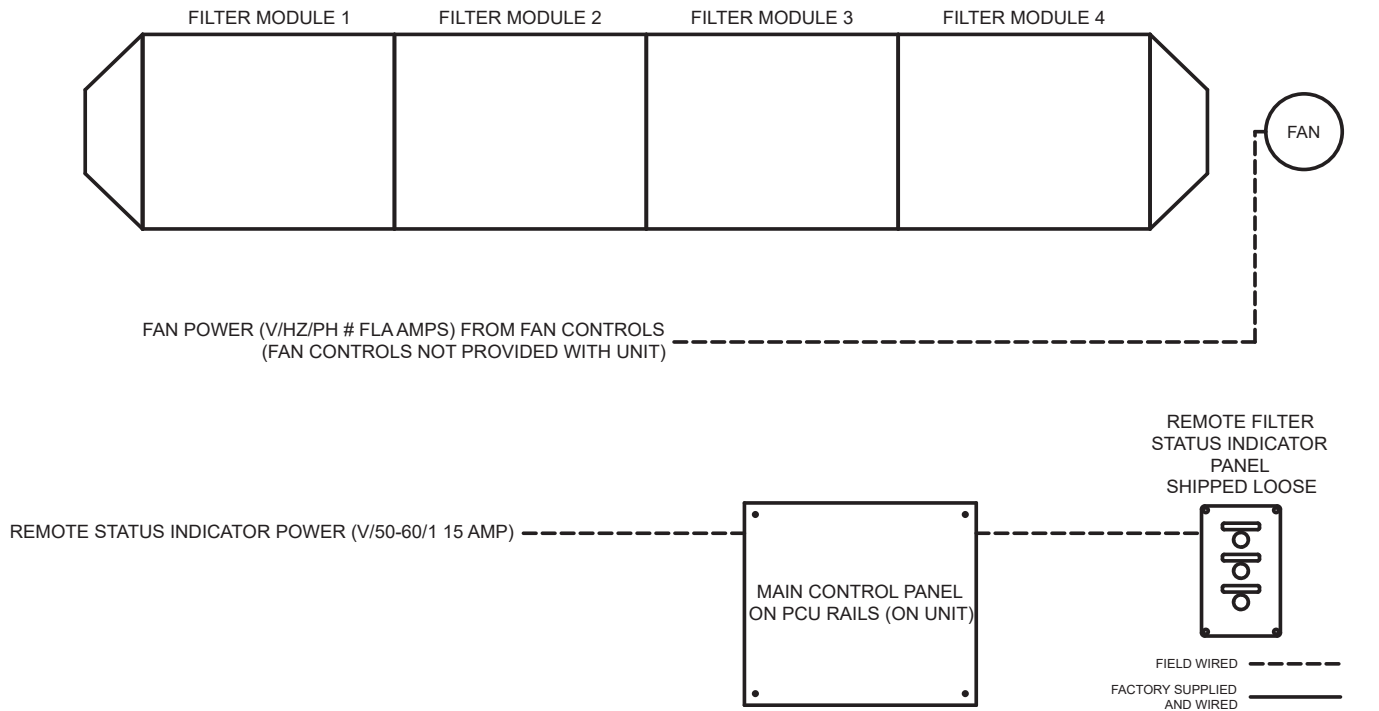

FIGURE #3: VIEW OF A NON ACCESS DOOR SIDE

Field Wiring Diagrams

Field diagrams are provided as general drawings. For unit specific drawings, consult wiring diagrams found on the unit control panel.

Unit with Remote Filter Status Indicator



Unit with System Control w/ VFD

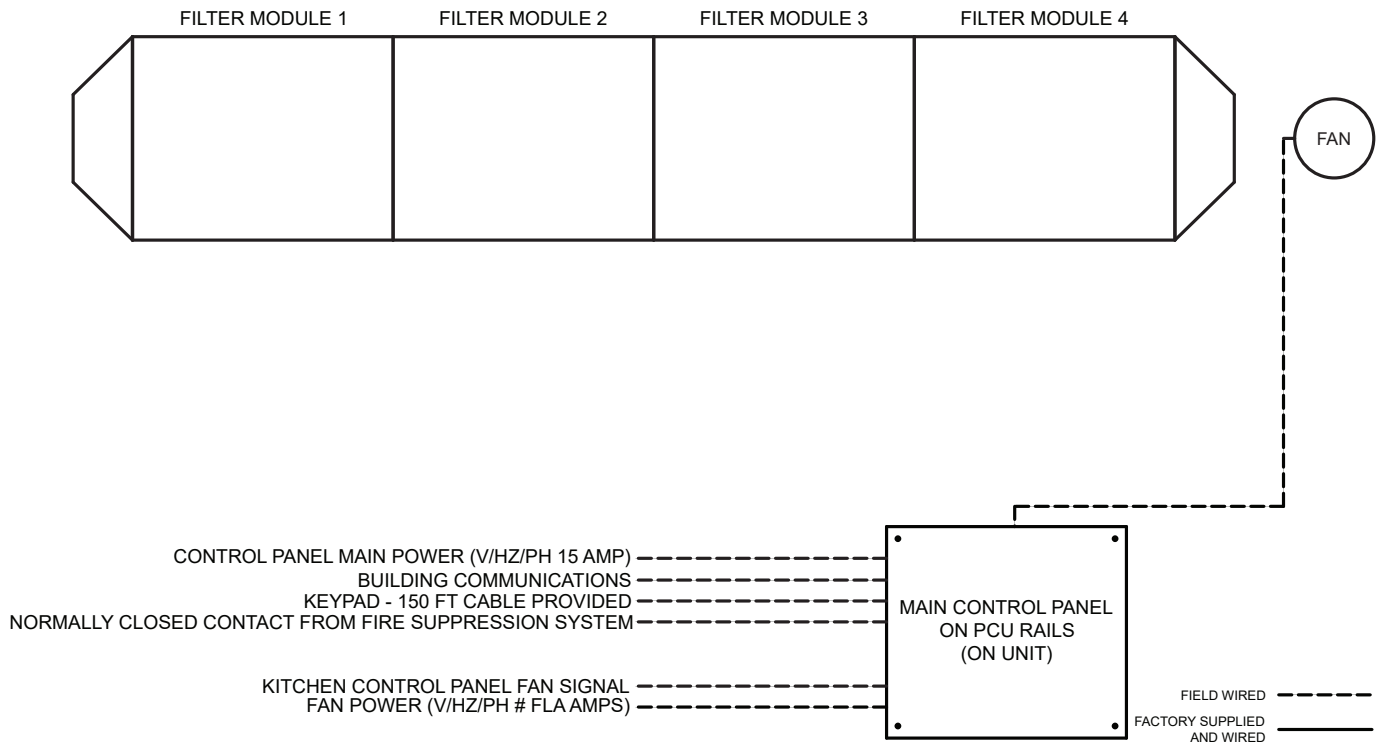

Field Wiring Diagrams

Fire Cabinet Heater Wiring Detail (Dwyer Controller)

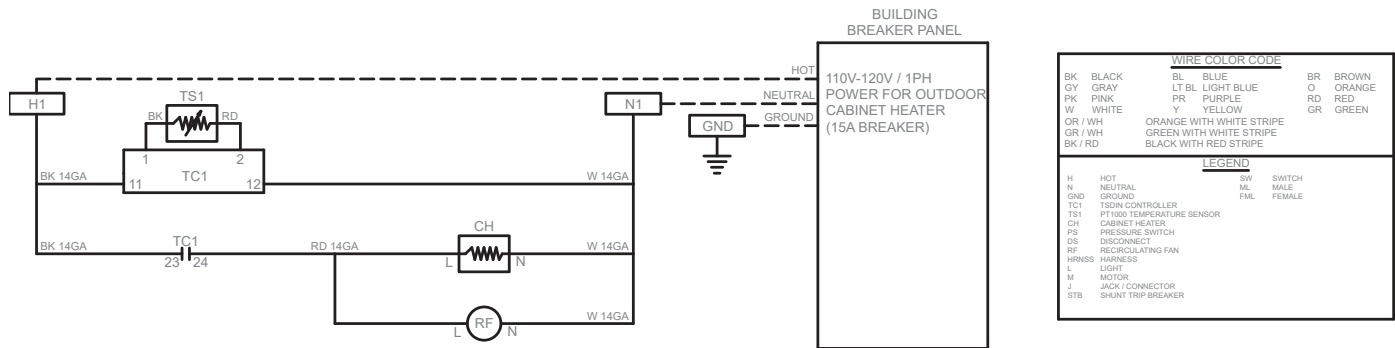

Dwyer Digital Controller Settings (for Cabinet Heater)

PARAMETER	SETTING	DESCRIPTION
St1	40.0	Setpoint Value Probe 1
St2	3.0	Setpoint Value Probe 2
St3	3.0	Setpoint Value Probe 3
r01	5.0	Differential Probe 1
r02	1.0	Differential Probe 2
r03	1.0	Differential Probe 3
r4	-50.0	Minimum Setpoint Value
r5	150.0	Maximum Setpoint Value
c01	inu	Mode Probe 1
c02	inu	Mode Probe 2
c03	inu	Mode Probe 3
c11	0.0	Minimum Output 1 Stop Time
c12	0.0	Minimum Output 2 Stop Time
c13	0.0	Minimum Output 3 Stop Time
c21	5.0	Minimum Output 1 On Time
c22	0.0	Minimum Output 2 On Time
c23	0.0	Minimum Output 3 On Time
c31	10.0	On Time Fault Probe 1 Cycle
c32	0.0	On Time Fault Probe 2 Cycle
c33	0.0	On Time Fault Probe 3 Cycle
c41	0.0	Off Time Fault Probe 1 Cycle
c42	0.0	Off Time Fault Probe 2 Cycle
c43	0.0	Off Time Fault Probe 3 Cycle
PO	F	Temp Scale
P11	0.0	Probe 1 Calibration
P12	0.0	Probe 2 Calibration
P13	0.0	Probe 3 Calibration
P2	YES	Decimal Point
P31	YES	Probe 1 Present
P32	NO	Probe 2 Present
P33	NO	Probe 3 Present
H2	NO	Keypad Protection
H4	0	Serial Communications Address
H5	0	Keypad Code
H6	Pt1	Type of Probe

PARAMETER PROGRAMMING

- Press and hold Set for 30 seconds or until 00 appears blinking
- Press Set key to enter parameter list
- With ▲ and ▼ go to the desired parameter on the list of parameters
- Press Set to see the current set value
- Press either ▲ or ▼ to set the desired new value
- Press Set to confirm it and exit to the parameter list
- Press Set plus ▼ to quit programming or wait 1 minute (keyboard timeout).

Field Wiring Diagrams

Fire Cabinet Heater Wiring Detail (Carel Controller)

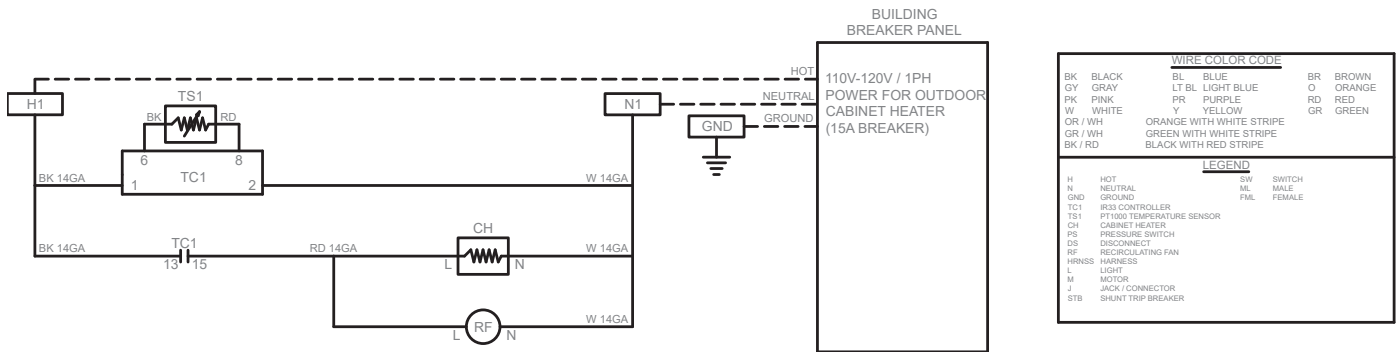

Carel Digital Controller Settings (for Cabinet Heater)

THERMOSTAT PROGRAMMING INSTRUCTIONS	
IR33 PARAMETER	SETTING
c0	2
P1	5.0
P3	0
c9	5
c10	1
c11	4
c13	3
P14	0
c18	1
c19	0
S11	40

THERMOSTAT SETPOINT ADJUSTMENT

- PRESS THE SET BUTTON TO SEE THE SETPOINT (S11).
- PRESS THE UP/DOWN ARROW BUTTON TO CHANGE THE SET POINT.
- PRESS THE SET BUTTON TO VIEW THE CURRENT TEMPERATURE.

Fire System Wiring - Ansul Electric Release

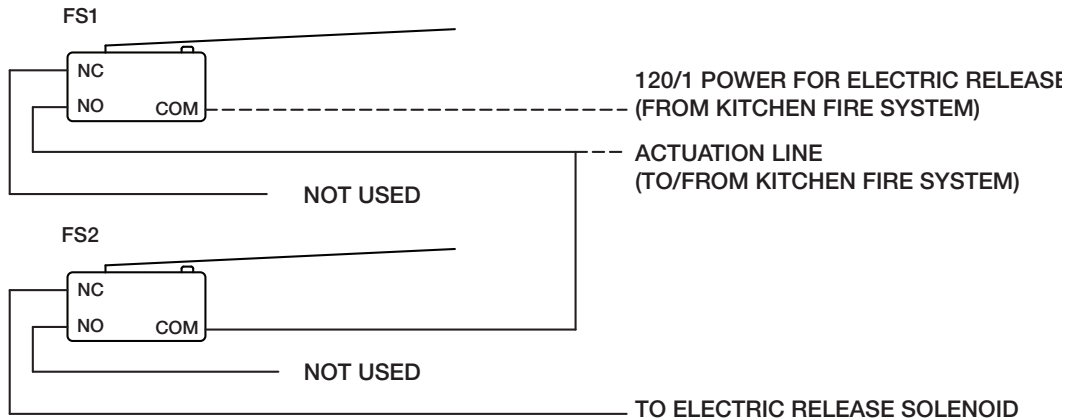

Remote Filter Status Indicator Wiring (if provided)

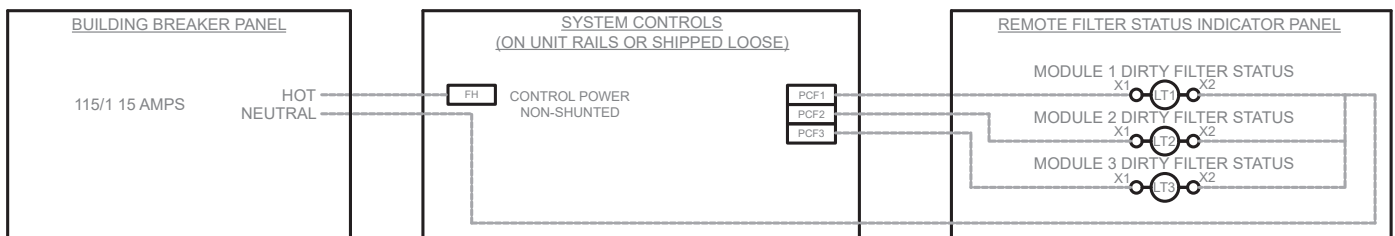

Our Commitment

As a result of our commitment to continuous improvement, Greenheck reserves the right to change specifications without notice.

Product warranties can be found online at Greenheck.com, either on the specific product page or in the literature section of the website at Greenheck.com/Resources/Library/Literature.

Greenheck Grease Trapper catalog provides additional information describing the equipment, fan performance, available accessories, and specification data.

AMCA Publication 410-96, Safety Practices for Users and Installers of Industrial and Commercial Fans, provides additional safety information. This publication can be obtained from AMCA International, Inc. at www.amca.org.

