

Refer to:

'Installation Instructions for Curtain Fire Dampers'
(Part #481324)

or

'Installation, Operation and Maintenance Instructions for
Multi-blade Fire & Combination Fire Smoke Dampers'
(Part #481318) for additional details.



Instructions

These instructions apply to 1½ hour rated Greenheck combination fire smoke dampers and fire dampers mounted horizontally in design I503 as detailed in the UL Fire Resistance Directory. UL design I503 is a 2 hour rated non-load bearing horizontal barrier constructed from steel studs and gypsum board. Specific requirements in these instructions are mandatory. These instructions meet the requirements of NFPA 90A (Standard for the Installation of Air Conditioning and Ventilating Systems).

Horizontal mount dampers up to a maximum size of 48 in. W x 48 in. H (1219 mm W x 1219 mm H) may be installed as described below.

1. Clearance Requirements

There are no minimum clearance requirements between the floor opening and the damper sleeve. However, to facilitate installation clearances between the floor opening and damper sleeve are recommended.

2. Securing the Damper/Sleeve Assembly to the Floor

Retaining angles are required above the floor and are optional below the floor. Retaining angles must be a minimum of 20 ga. (1 mm). The leg of the retaining angle on the damper sleeve shall be a minimum of 1¼ in. (32 mm). The leg of the retaining angle on the floor shall be long enough to cover any annular space and overlap the floor by at least 1 in. (25mm).

• Retaining angles must be attached to the sleeve using one of the following methods:

- Tack or spot welds
- #10 sheet metal screws
- ¼ in. (6 mm) nuts and bolts

A minimum of two connections are required on each side. Connections shall be no more than 2 in. (51 mm) from the corners and no more than 6 in. (152 mm) on center.

• Retaining angles must be attached to the floor using a minimum of 2 screws per side no more than 6 in. (152 mm) from the corners. Fasteners shall be 6 x 1⅞ in. (152 mm x 48 mm) (minimum) self-drilling screws.

3. Framing Requirements

- The sides of the damper parallel to the floor studs shall be framed by 2 – steel studs positioned back to back with a steel track overlapping the stud facing the damper sleeve. See **Figure 1**.
- The sides of the damper perpendicular to the floor studs shall be framed by a steel track.

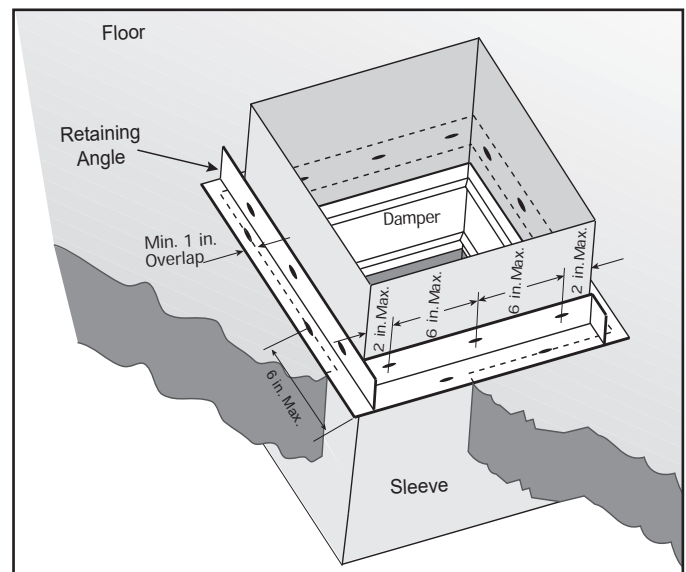
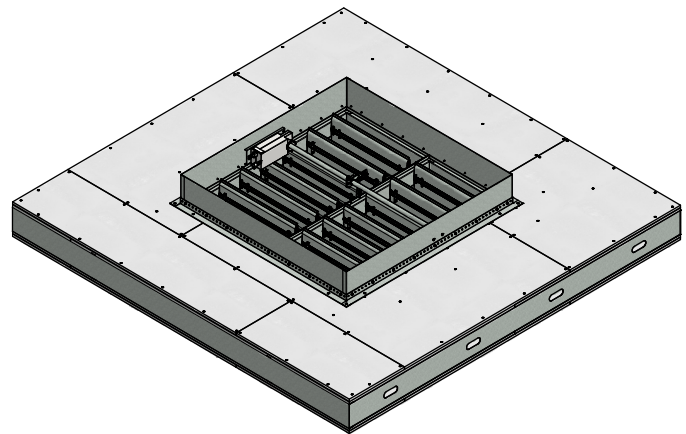

- The opening shall be lined with 5/8 in. (16 mm) thick USG type C gypsum board as shown in **Sec A-A**.
- The gypsum board shall be screwed to the studs and track that frame out the damper opening on no more than 12 inch (305 mm) on center.

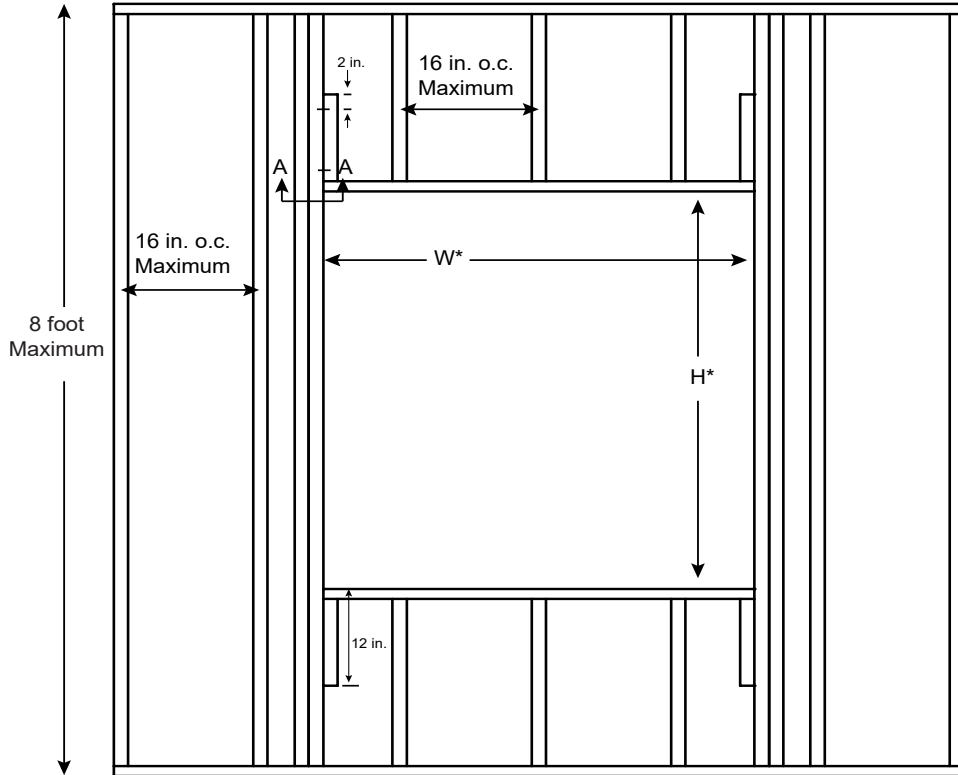

*Framed out opening for the damper shall be large enough to account for the opening to be lined with 5/8 in. thick gypsum board plus any desired annular space.

Figure 1: Framing Detail

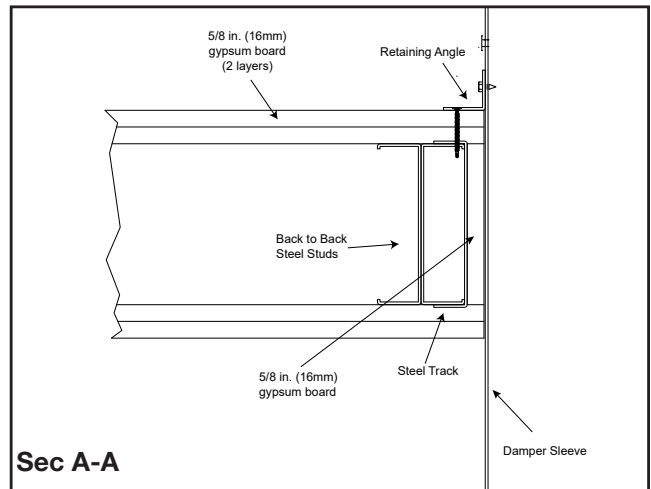

Our Commitment

As a result of our commitment to continuous improvement, Greenheck reserves the right to change specifications without notice.

Product warranties can be found online at Greenheck.com, either on the specific product page or in the literature section of the website at Greenheck.com/Resources/Library/Literature.

