

Installation, Operation and Maintenance Manual

Please read and save these instructions for future reference. Read carefully before attempting to assemble, install, operate or maintain the product described. Protect yourself and others by observing all safety information. Failure to comply with these instructions will result in voiding of the product warranty and may result in personal injury and/or property damage.

Maximum Wind-load: +/-150 PSF

Channel Installation

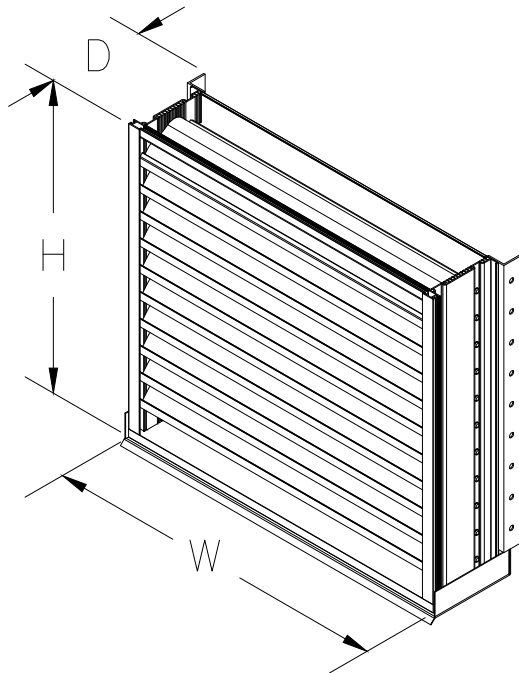

Flange/Sleeve Installation

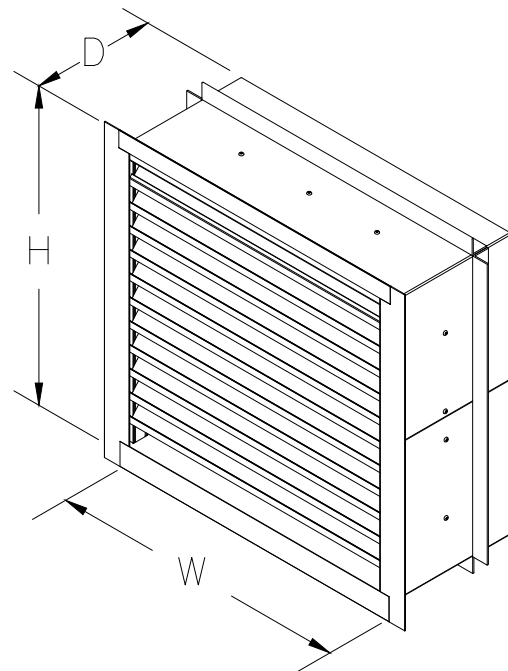

Channel Installation

Maximum Size and Installation Information

Model ESD-635DE is a Miami-Dade Approved and Florida Product Approved louver and must be installed in accordance with the installation instructions shown herein. Model ESD-635DE is qualified for installation within concrete/masonry, steel stud, structural steel or wood framed building conditions. Model ESD-635DE is structurally calculated to withstand positive and negative wind-loads up to +/-150 PSF. The maximum typical rough opening height is limited to 48.50 in. and the typical rough opening width is limited to 48.75 in.

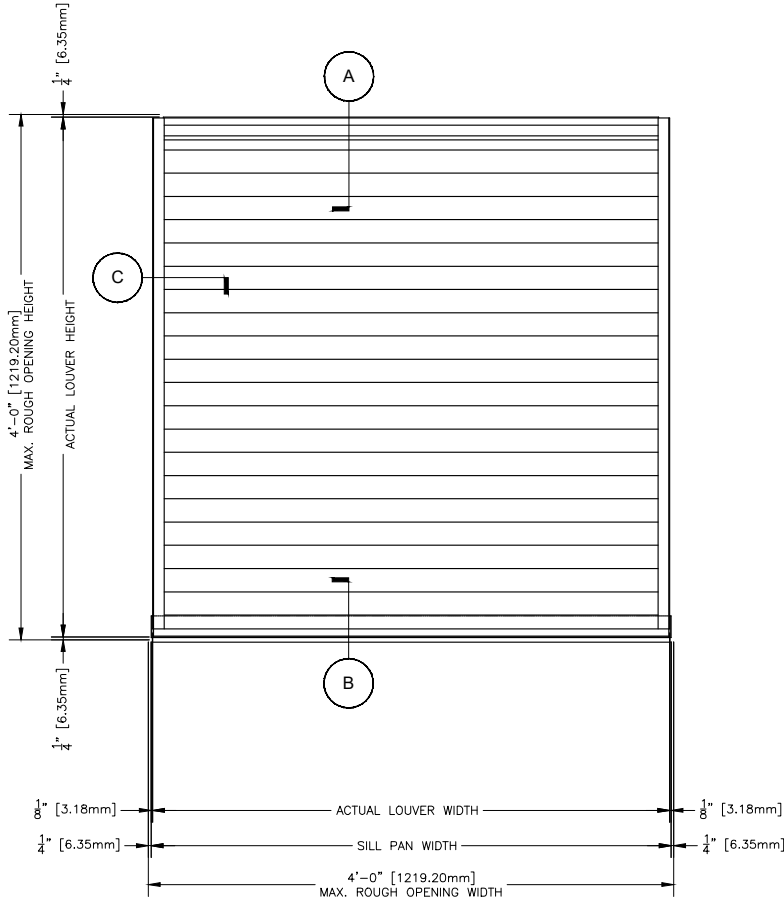

Minimum Typical Rough Opening Size
 12 in. W x 7 in. H

Maximum Typical Rough Opening Size
 48.75 in. W x 48.50 in. H

Building Condition/Substrate Limitations

Channel Installation

- All steel substrate should be min. 16 Ga. FY= 33 KSI
- All concrete substrate shall be min. 2000 PSI
- All concrete masonry shall be ASTM C90, Type II, grout-filled
- All wood substrate shall be G= 0.42 density or better
- All aluminum substrate shall be min 0.125 in. thick FY=16 KSI



Channel Installation

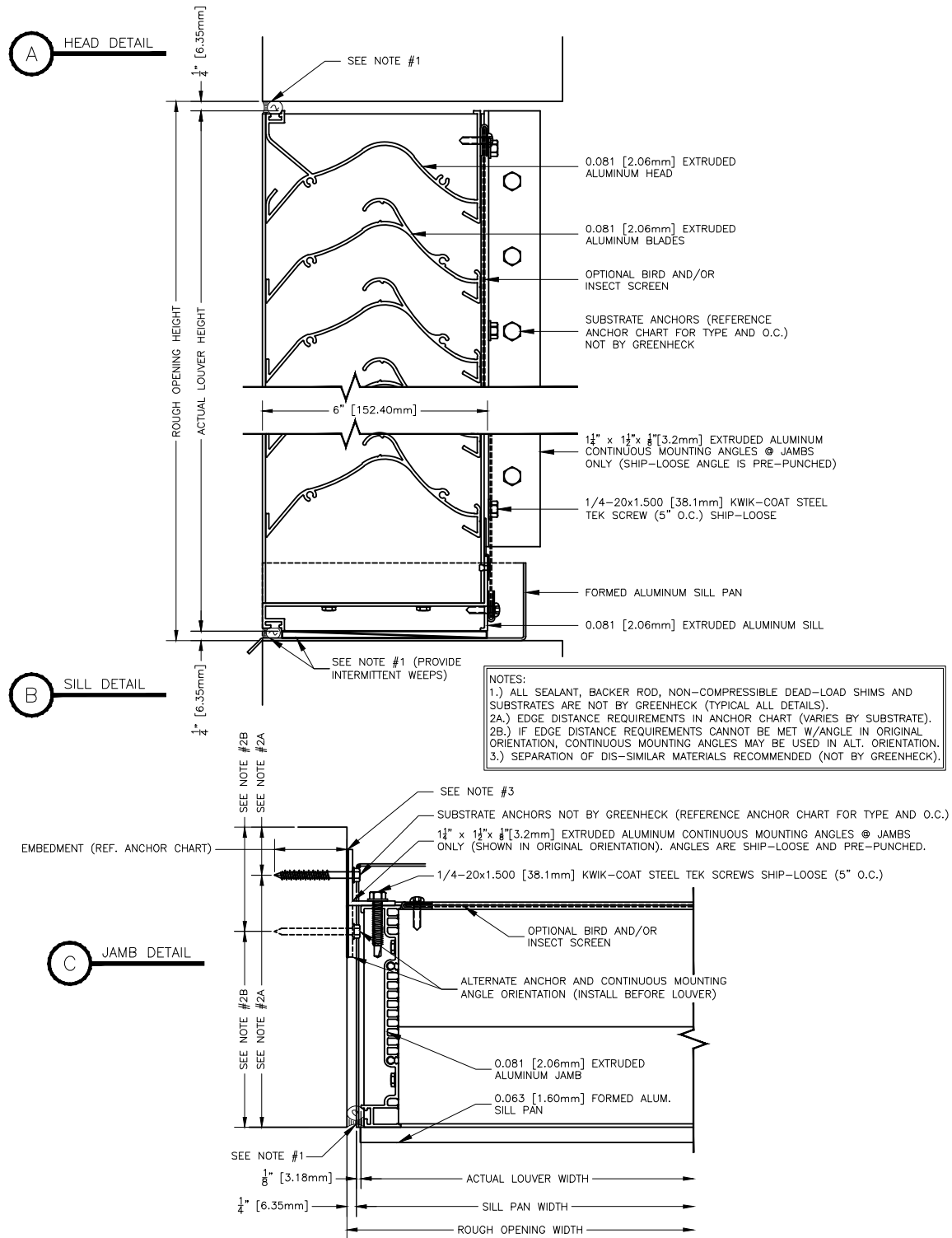

Channel Installation

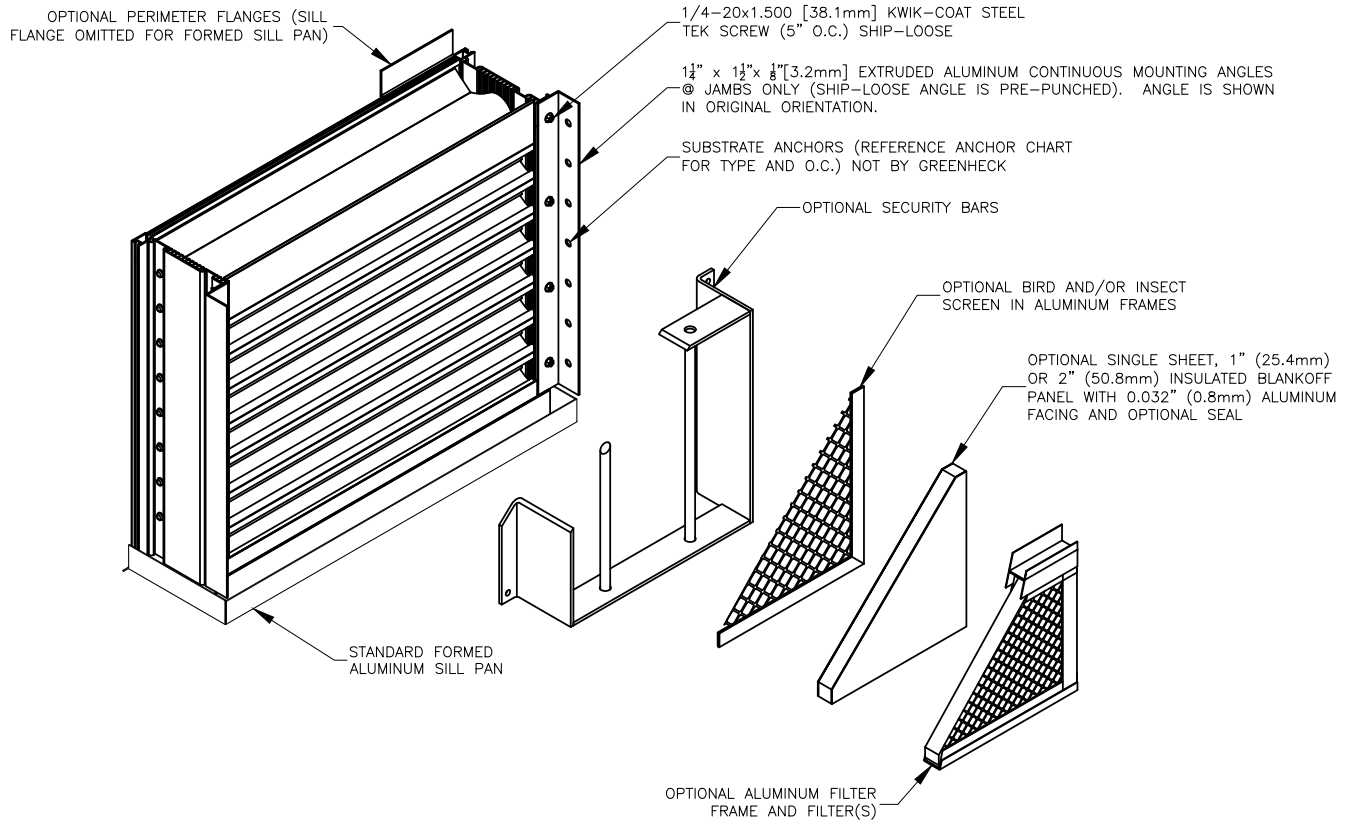

Channel Installation

SUBSTRATE AND FASTENER TABLE															
ITEM 31, SUBSTRATE			ITEM 30, SUBSTRATE FASTENER												
TYPE	THICKNESS MIN	MATERIAL MIN	TYPE (ALL FASTENERS ARE HEX HEAD STYLE)	MAT'L	DIA.	EDGE MIN	EMBED. MIN	ANCHOR SPACING	HEAD DIA. MIN	ANGLE HOLE ITEM 5, MAX	SUBSTRATE HOLE, MAX				
WOOD	3	G OF 0.42	LAG SCREW, 3 INCH MIN LENGTH	*	1/4	1 1/2	23/32	4	1/2	5/16	SEE FASTENER MANUFACTURER INSTRUCTIONS				
					3/8	1 1/2	23/32	6	5/8	7/16					
STEEL	16 GA (0.056)	Fy 33 KSI Fu 45 KSI	BOLT W/ NUT	*	1/4-20	5/8	0.056	8	1/2 HEAD 9/16 NUT	5/16	SEE FASTENER MANUFACTURER INSTRUCTIONS				
	14 GA (0.070)		4												
	12 GA (0.099)		6												
			THREAD CUTTING/TAPPING SCREW				0.070	8							
							0.099	8							
ALUMINUM	1/8	6063-T5	BOLT W/ NUT	*	1/4-20	1/2	1/8	8	1/2 HEAD 9/16 NUT	5/16	1/4				
			THREAD CUTTING/TAPPING SCREW					8	1/2			SEE FASTENER MANUFACTURER INSTRUCTIONS			
CONCRETE	VARIES WITH SIZE OF FASTENER USED, SEE FASTENER MANUFACTURER INSTRUCTIONS	2 KSI	BUILDEX TAPCON (BLUE, WHITE, OR 410 SS)	VARIES	1/4	1 1/2	1 1/2	4	AS MANUFACTURED	1/4	SEE FASTENER MANUFACTURER INSTRUCTIONS				
						2 1/4		6							
						2 1/2		6							
						3	6	1 1/4	4						
						1 1/2	4								
						2	6								
						3	6	1 3/4	6						
						1 1/2	6								
						3	6								
						2.3 KSI	ELCO AGGRE-GATDR	300 SS	1/4	1 1/2		1 3/8	6	AS MANUFACTURED	1/4
												1 3/4	6		
						2.9 KSI	ELCO ULTRACON SS4	410 SS	1/4	1		1 3/4	4	AS MANUFACTURED	1/4
												2 1/2	8		
						3.4 KSI	ELCO CRETE-FLEX SS4, SMALL HEAD	410 SS	1/4	1		1 3/4	6	AS MANUFACTURED	1/4
							ELCO CRETE-FLEX SS4, FLANGED HEAD						8		
2.5 KSI	POWERS 316 STAINLESS STEEL WEDGE-BOLT	316 SS	1/4	1 1/2	1 7/8	4	AS MANUFACTURED	5/16							
						2	6								
					2 3/4	6									
3/8					2 3/8	4	AS MANUFACTURED	7/16							
						2	6								
					2 1/2	8									
					1 1/8	1 1/2	4	AS MANUFACTURED	5/16						
2 KSI	POWERS WEDGE-BOLT PLUS	STEEL	1/4	2	8										
4 KSI				1 1/8	4										
				1 5/8	8										
2 KSI					1 1/8	2	AS MANUFACTURED	7/16							
4 KSI					2 1/8	8									
					1 1/8	4									
					1 3/4	8									
GROUT FILLED CMU	NOTE 1	ELCO AGGRE-GATDR	300 SS		2	2	8	AS MANUFACTURED	1/4	SEE FASTENER MANUFACTURER INSTRUCTIONS					
	NOTE 2	ELCO ULTRACON SS4	410 SS	1/4	2	1	2								
	NOTE 3	POWERS WEDGE-BOLT PLUS	STEEL	3/8	2	2 1/2	6								
							8		7/16						

NOTE *: LAG SCREWS SHALL HAVE STRENGTHS OF MINIMUM GRADE 1 STEEL, OTHER BOLT AND SCREWS SHALL HAVE STRENGTHS OF MINIMUM GRADE 2 STEEL.
 NOTE 1: CONCRETE MASONRY (CMU) SHALL BE > THE FOLLOWING: 6" WIDE, CMU CONFORMING TO ASTM C-90 FILLED WITH 4,747 KSI GROUT.
 NOTE 2: CONCRETE MASONRY (CMU) SHALL BE > THE FOLLOWING: 6" WIDE, 2 KSI CMU CONFORMING TO ASTM C-90 WITH 1624 KSI GROUT.
 NOTE 3: CONCRETE MASONRY (CMU) SHALL BE > THE FOLLOWING: 6" WIDE, GRADE N, TYPE II, LIGHT-WEIGHT/MEDIUM-WEIGHT/NORMAL-WEIGHT CMU CONFORMING TO ASTM C-90. MORTAR MUST BE TYPE N.

Flange/Sleeve Installation

Maximum Size and Installation Information

Model ESD-635DE is a Miami-Dade Approved and Florida Product Approved louver and must be installed in accordance with the installation instructions shown herein. Model ESD-635DE is qualified for installation within concrete/masonry, steel stud, structural steel or wood framed building conditions. Model ESD-635DE is structurally calculated to withstand positive and negative wind-loads up to +/-150 PSF. The maximum typical rough opening height is limited to 48.50 in. and the typical rough opening width is limited to 48.5 in.

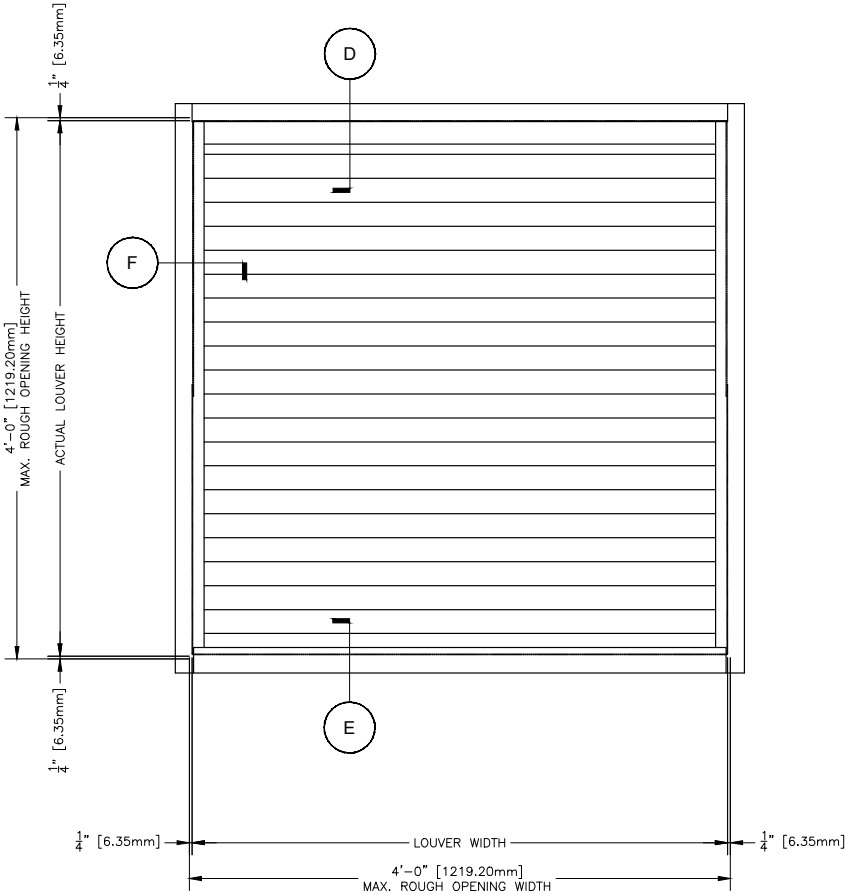

Minimum Typical Rough Opening Size
 12 in. W x 7 in. H

Maximum Typical Rough Opening Size
 48.50 in. W x 48.50 in. H

Building Condition/Substrate Limitations

Flange/Sleeve Installation

- Any substrate acceptable that is capable of withstanding imposed loads.



Flange/Sleeve Installation

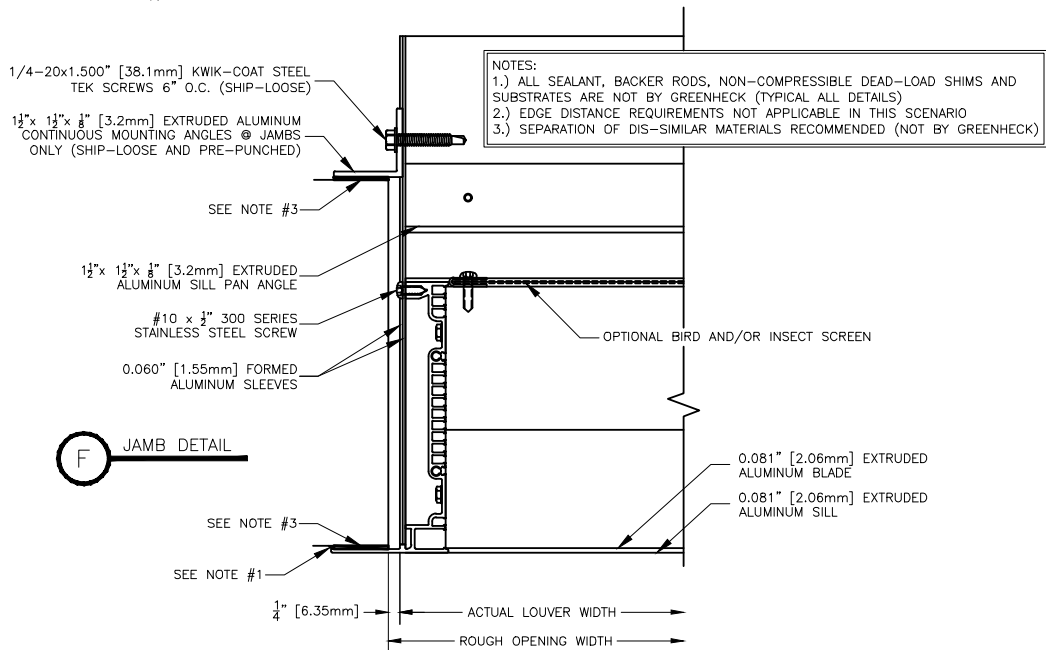
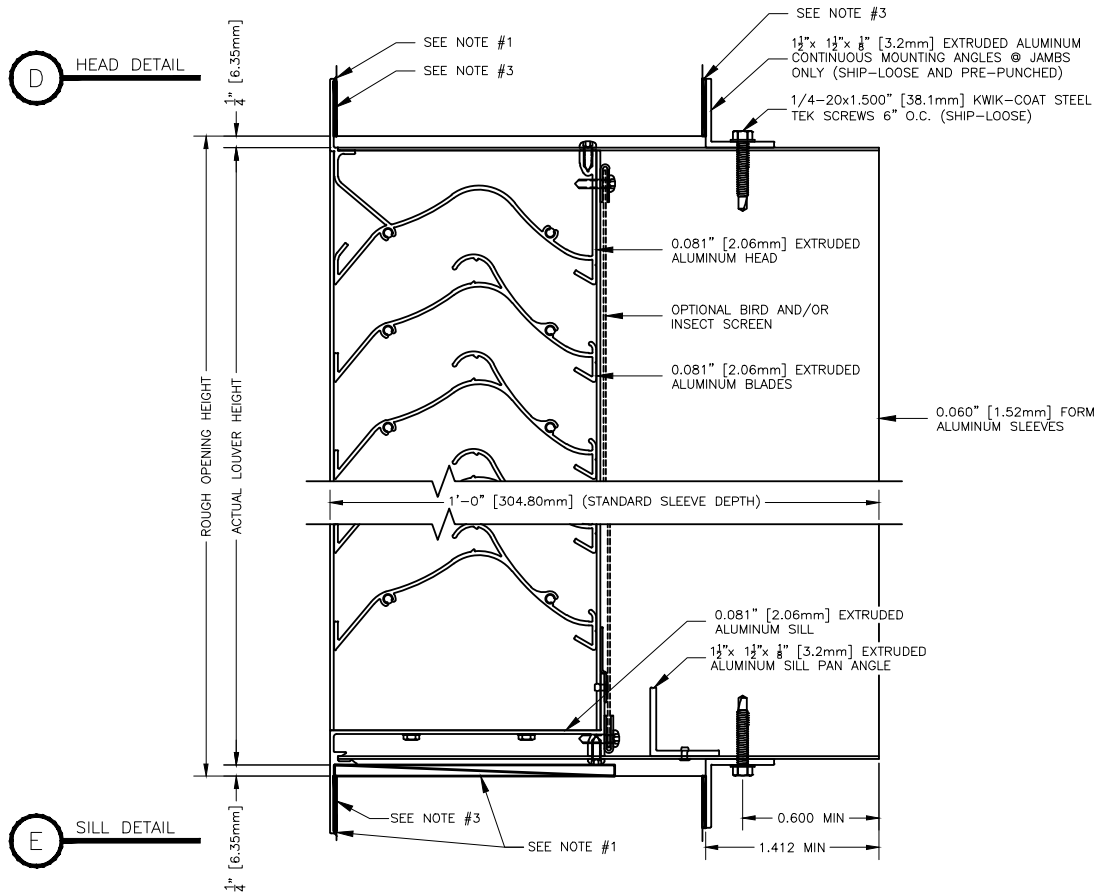

Flange/Sleeve Installation

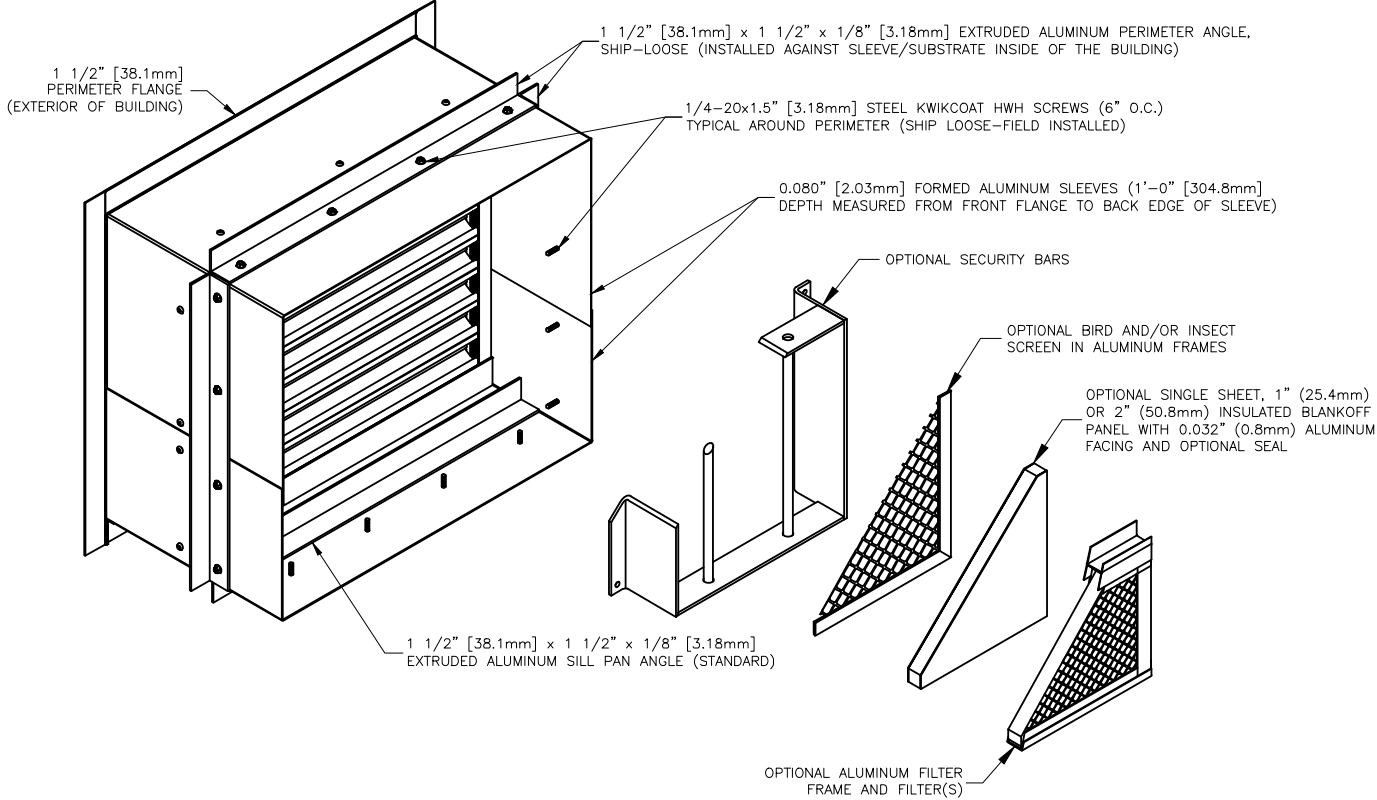

Our Commitment

As a result of our commitment to continuous improvement, Greenheck reserves the right to change specifications without notice.

Product warranties can be found online at Greenheck.com, either on the specific product page or in the literature section of the website at Greenheck.com/Resources/Library/Literature.

