

These instructions address how to mount a jumpover bracket when you want to join two damper sections.

Applicable to Models

VCD-20, VCD-23, VCD-33, VCD-34, VCD-42, and VCD-43

Kit Number 879586: VCD-20 and VCD-23

The jumpover bracket can be used on dampers 10 inches or higher (under 10 inches the blades are too small to support the bracket).

1. To determine which blade to attach the jumpover bracket to the damper blade, always attach to the same drive blade that contains the actuator or manual quadrant.
2. Drill the jumpover bracket into the drive blade. Attach jumpover bracket to the blade with TEK screws.
3. A support bracket will need to be attached to the drive blade. The support bracket will arrive with the holes pre-drilled. This bracket will need to be cut to length depending on the size of the damper. Drill support bracket into the blade as shown (You may use duct tape, clamp, etc. to keep bracket in place while drilling).

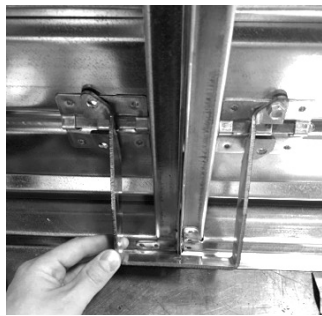

Figure 1: Mounting Jumpover Bracket



Figure 2: Mounting Support Bracket

ITEM	QTY	PART NO.	DESCRIPTION
1	1	755265	BRKT, JUMP-OVER GALV
2	4	415264	TCS 23 1/4-20X1/2 HWH MZP
3	1	REF	DAMPER SV JUMP-OVER, G2
4	1	755268	REINF. 18.00IN GALV SV BLADE
5	VARIES	415586	TEK SCR.HWH#14-14X.75.CLIM.SL.#3

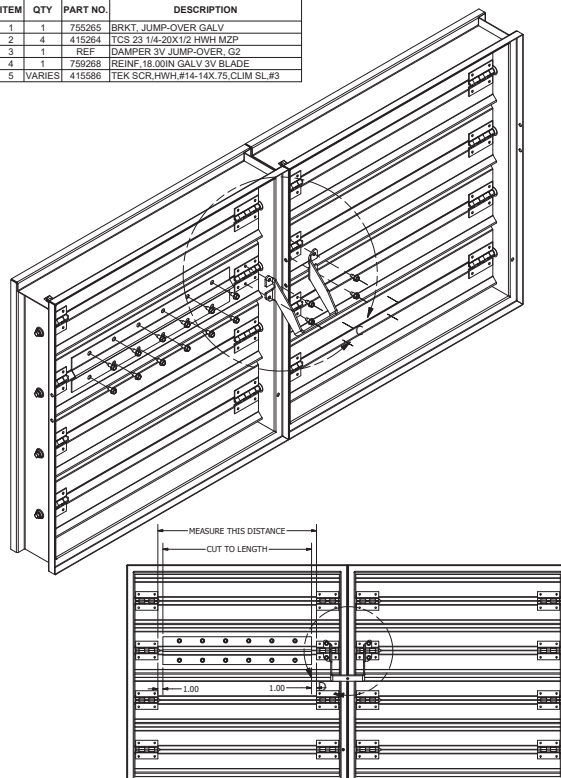
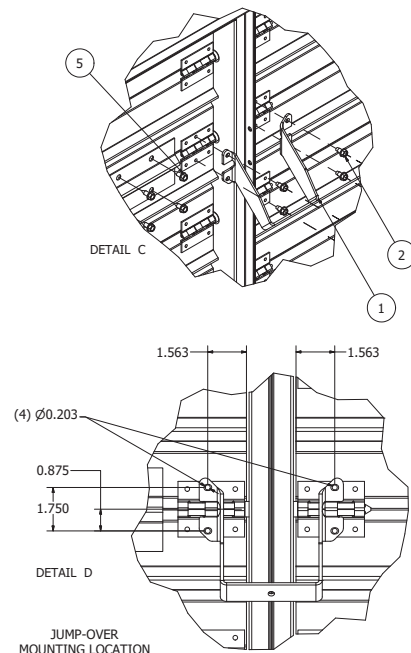

Figure 3: Jumpover Bracket



Kit Number 879587: VCD-33 and VCD-34

The jumpover bracket can be used on dampers 10 inches or higher (under 10 inches the blades are too small to support the bracket).

1. To determine which blade to attach the jumpover bracket to the damper blade, always attach to the same drive blade that contains the actuator or manual quadrant.
2. Drill the jumpover bracket into the drive blade. Attach jumpover bracket to the blade with TEK screws.

ITEM	QTY	PART NO.	DESCRIPTION
1	1	755265	BRKT, JUMP-OVER GALV
2	4	415490	CS, 1/4-20x1.25 HH,ZP
3	4	415516	NUT, 1/4-20 HEX ZP NYLOCK
4	1	REF	DAMPER, AF, G2

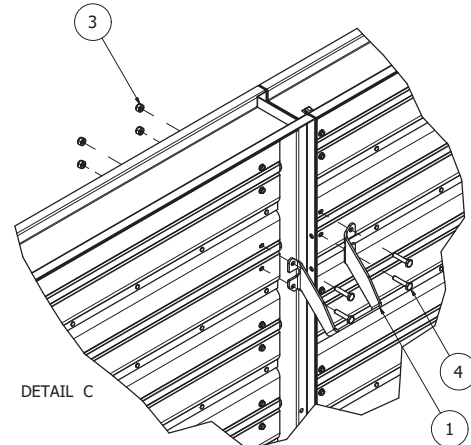
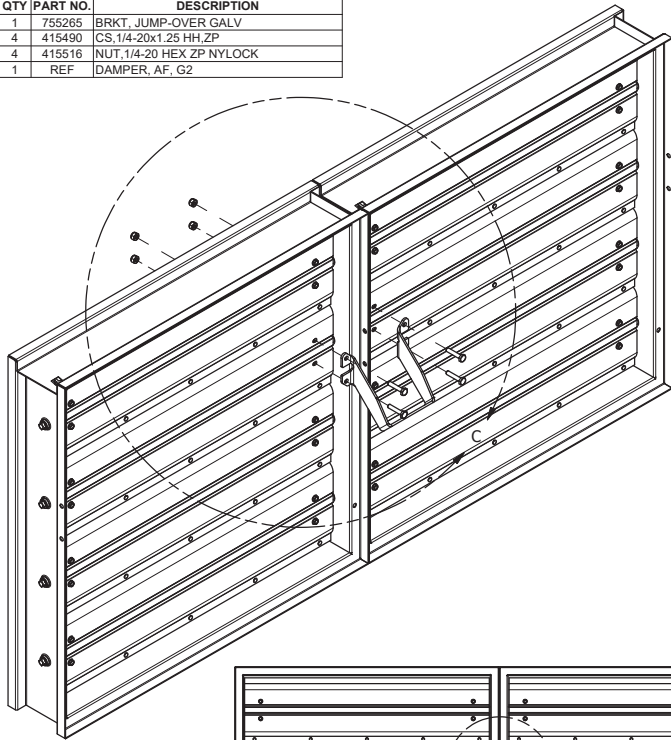

(4) $\varnothing 0.266$
 DRILL 17/64" HOLE
 THROUGH ENTIRE BLADE
 THICKNESS TO ALLOW
 CLEARANCE FOR FASTENERS.

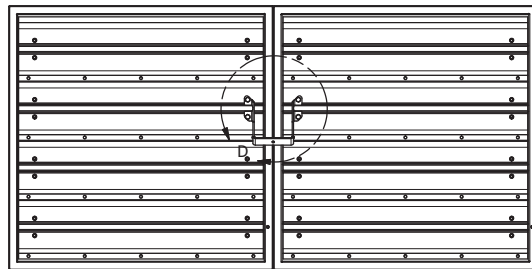
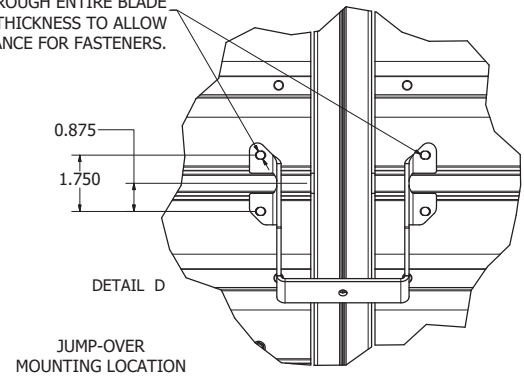

NOTE:

1. TIGHTEN NUTS AND BOLTS WITHOUT DEFORMING THE BLADE SKINS



Kit Number 879587: VCD-42 and VCD-43

The jumpover bracket can be used on dampers 10 inches or higher (under 10 inches the blades are too small to support the bracket).

1. To determine which blade to attach the jumpover bracket to the damper blade, always attach to the same drive blade that contains the actuator or manual quadrant.
2. Drill the jumpover bracket into the drive blade. Attach jumpover bracket to the blade with TEK screws.

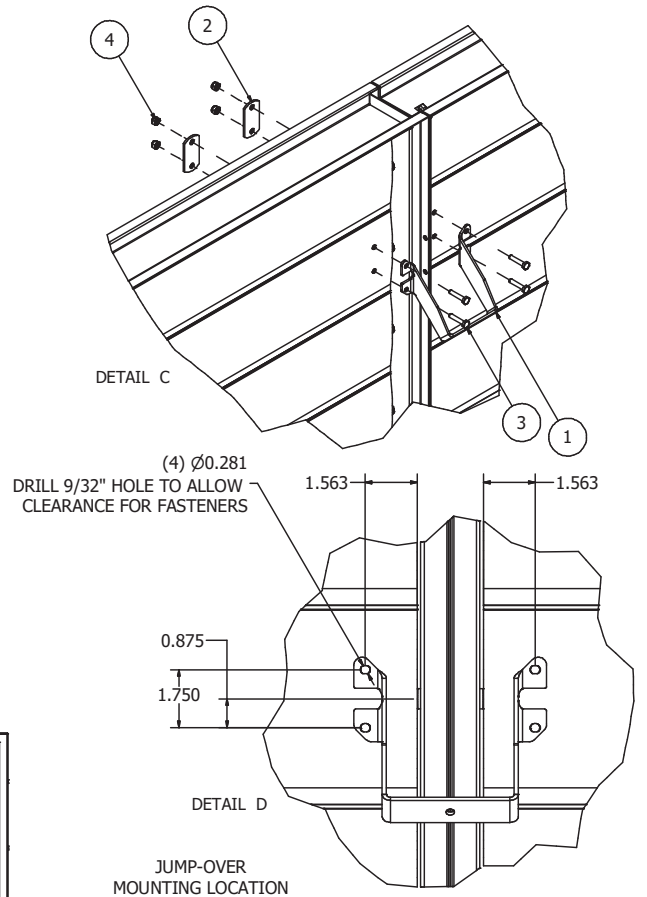
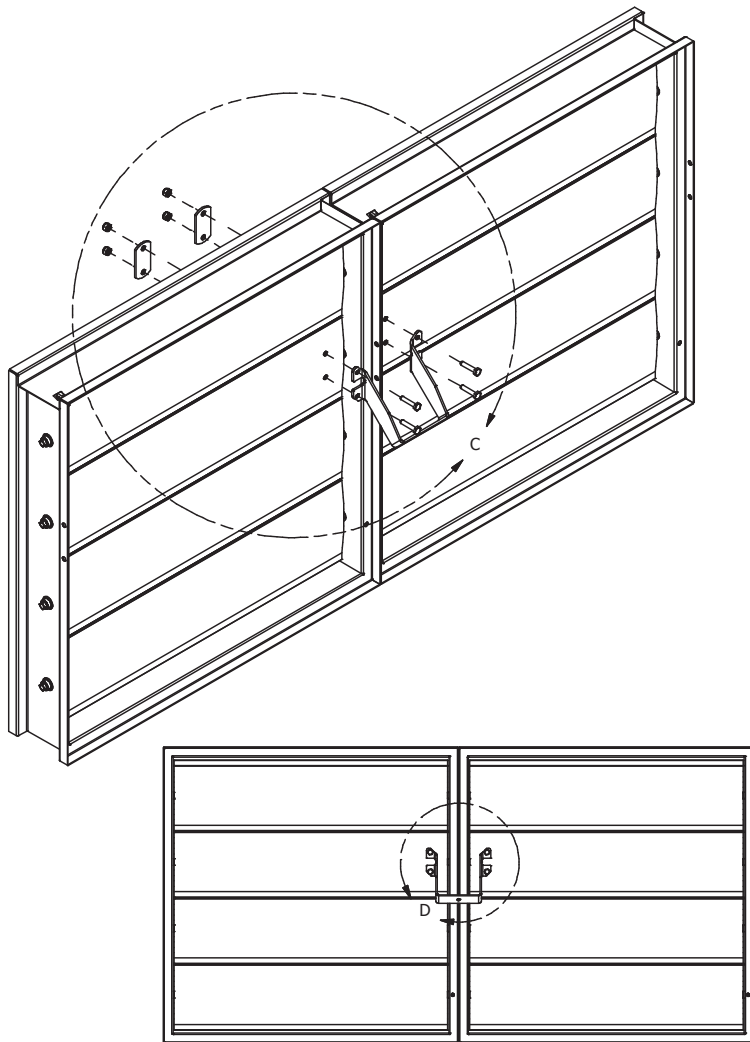

ITEM	QTY	PART NO.	DESCRIPTION
1	1	755265	BRKT, JUMP-OVER GALV
2	2	507532	REINFORCING STRAP
3	4	415490	CS, 1/4-20x1.25 HH.ZP
4	4	415516	NUT, 1/4-20 HEX ZP NYLOCK
5	1	REF	ASM, EXTD AF, GALV, G2

