

Application

The AMD-23-TD combines the functionality of a highly accurate thermal dispersion airflow measuring station and a low leakage control damper into one compact assembly that both measures and regulates airflow volumes to a target set-point.

Ratings

Velocity

100 - 2000 fpm (0.5 - 10.2 m/s)

Leakage

6 cfm/ft² @ 4 in. wg (110 cmh/m² @ 1 kPa)
3 cfm/ft² @ 1 in. wg (55 cmh/m² @ 0.25 kPa)

Temperature

-20°F to 140°F (-29°C to 60°C). Consult factory for temperature lower than -20°F (-29°C)

Monitor Accuracy

2-3% of reading

Construction

	Standard	Optional
Frame Material	Galvanized Steel	-
Frame Material Thickness	16 ga. (1.5 mm)	12 ga. (2.7 mm)*
Frame Type	5 in. x 1 in. hat channel	-
Blade Material	Galvanized steel	-
Blade Type	3V	-
Blade Action	Parallel	-
Linkage	Plated steel out of airstream, concealed in jamb	316SS
Axle Bearings	Synthetic (acetal) sleeve type	316SS
Axle Material	Plated steel	316SS
Blade Seals	TPE	Silicone
Jamb Seals	Stainless Steel	-
Sleeve	15 in. (381 mm)	15 in. - 48 in. (381 mm - 1219 mm)
Sleeve Gauge	20 ga.	14 ga. or 16 ga.
Flange	None	1½ in. (38mm); Upstream side, Downstream side, Both Sides
Air Straightener	None	Polycarbonate Honeycomb
Actuator	24 VAC 50/60 Hz modulating, spring return	24 VDC modulating, Manual quadrant

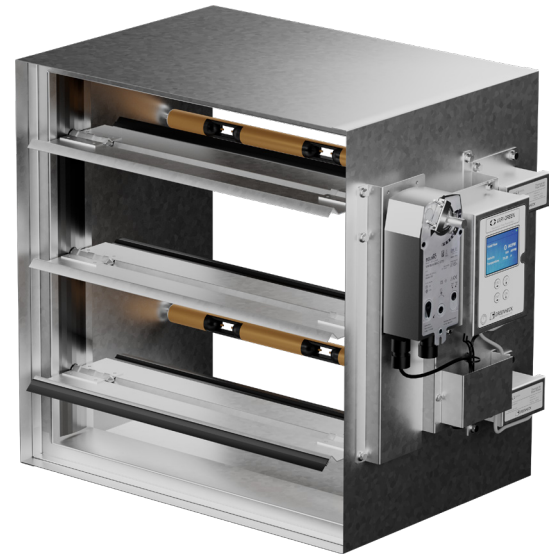

W & H dimension furnished approximately ¼ in. (6mm) undersize.

W x H	Minimum Size	Maximum Size	
	External	Single Section	Multiple Section
Inches	12 x 612	48 x 74	118 x 74
mm	305 x 305	1219 x 1880	2997 x 1880

Features and Options

- 24 VAC modulating actuator mounted externally or internally (NEMA 2)
- Optional factory supplied controller
 - Analog
 - BACnet MS/TP
- Clean wrap
- Retaining angle
- Flow straightener

*When 12 ga. frame is selected and the damper height is less than 17 inches, low profile top and bottom frame members are utilized. These low profile frame members will be made from 16 ga. material.

Document Links

[Installation Instructions](#)



[AMD-TD Transmitter Instructions](#)



[Air Measuring Products Catalog](#)



[Damper Selection Guide](#)



[Specifications](#)



[Warranty](#)

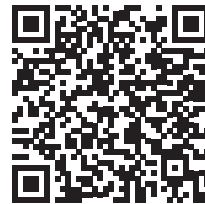

Vari-Green Thermal Dispersion Technology

Design

The AMD-23-TD comes standard with Vari-Green thermal dispersion probes factory installed in the damper sleeve, a modulating actuator and a Vari-Green airflow measurement transmitter that outputs a signal proportional to the cfm going through the unit.

The transmitter and actuator are factory wired to a terminal block for easy single-point wiring. The optional factory supplied controller makes the AMD-23-TD a turn-key solution for the measurement and control of airflow. Factory supplied controllers configured for analog operation accept a 0-10 VDC setpoint signal proportional to the required cfm and output a 0-10 VDC signal proportional to the real-time cfm going through the unit. Factory supplied controllers can also be ordered with BACnet MS/TP communication capabilities. See the installation and operation manual for a list of the BACnet data-points.

Vari-Green airflow measurement probes and transmitters utilize thermal dispersion technology to accurately measure airflow down to 0 fpm. Each probe comes with one or more airflow measuring nodes that contain precision matched thermistors. In each node one thermistor measures the ambient air temperature and the other is heated to a preset temperature differential above ambient. The air velocity is measured at each node by using the known relationship between heat transfer and air velocity and by measuring the power consumption necessary to maintain the fixed temperature difference between the thermistors. The Vari-Green transmitter then averages the velocities at each node to determine the overall cfm going through the AMD-23-TD.



The nodes in Vari-Green probes utilize a highly engineered injection molded aperture that straightens the airflow as it passes over the thermistors to produce an accurate measurement.

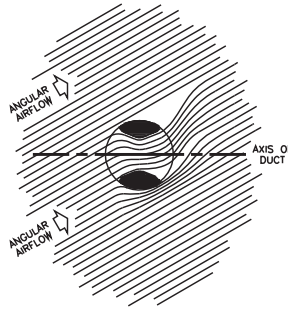

Each Vari-Green airflow transmitter has multi-line, back-lit, graphical LCD that provides continuous display of cfm, velocity and ambient air temperature.



Mounting Styles and Leakage Data

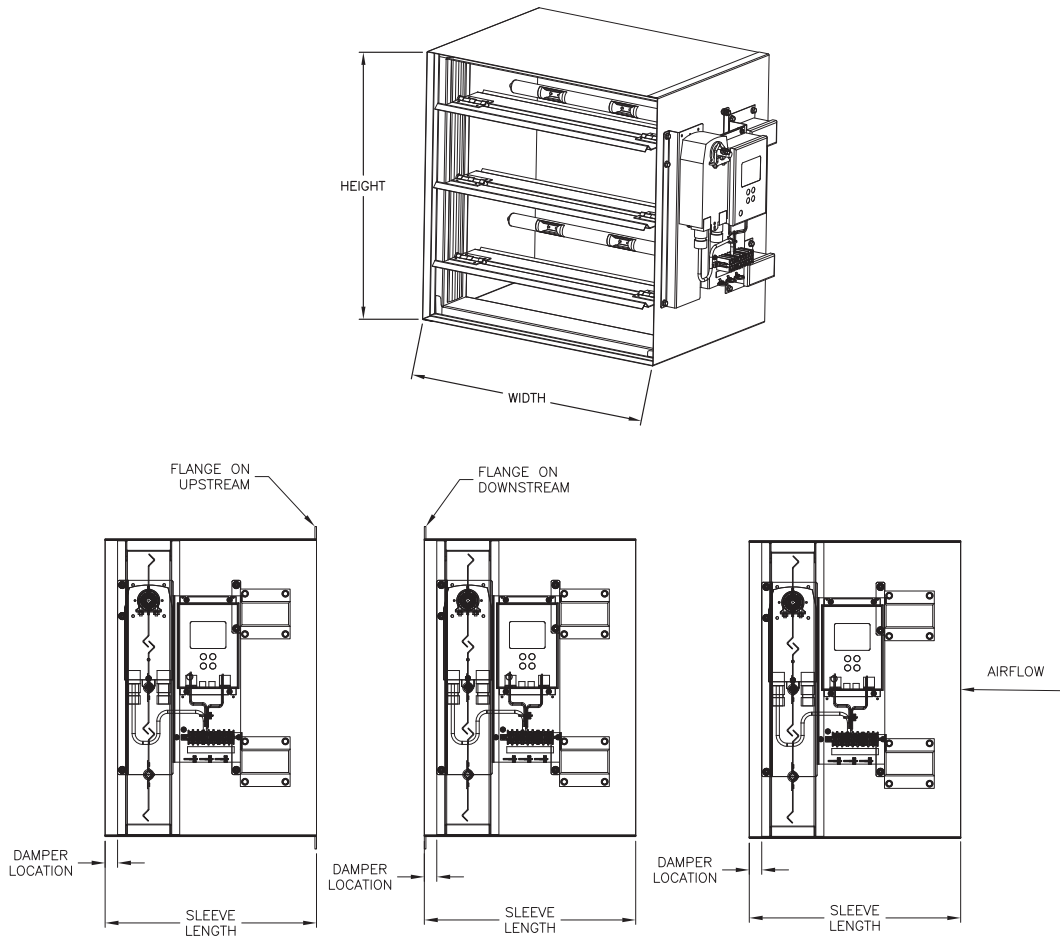

Leakage Data

Air leakage is based on operation between 32°F (0°C) and 120°F (49°C).

Tested for leakage in accordance with ANSI/AMCA Standard 500-D, Figure 5.5.

Tested for air performance in accordance with ANSI/AMCA Standard 500-D, Figures 5.2, 5.3 and 5.5.

Torque

Data are based on a torque of 5.0 in.lb./ft² (0.56 N·m) applied to close and seat the damper during the test.

AMD-23-TD	Leakage Class*	
Maximum Damper Width	1 in. wg (0.25 kPa)	4 in. wg (1 kPa)
60 in. (1524 mm)	1A	1

*Leakage Class Definitions

The maximum allowable leakage is defined by AMCA as the following:

- Leakage Class 1A - 3 cf_m/ft² @ 1 in. wg (class 1A is only defined at 1 in. wg).
- Leakage Class 1
 - 4 cf_m/ft² @ 1 in. wg
 - 8 cf_m/ft² @ 4 in. wg
 - 11 cf_m/ft² @ 8 in. wg
 - 12.6 cf_m/ft² @ 10 in. wg

Pressure Drop Data

Thermal Dispersion Damper with VCD-23 Control Damper

AMCA 5.2

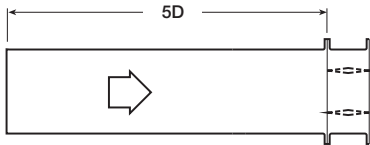

12 in. x 12 in. (305mm x 305mm)

Velocity (fpm)	Pressure Drop (in. wg)
500	0.05
1000	0.15
1500	0.31
2000	0.52
2500	0.80
3000	1.12
3500	1.51
4000	1.92

24 in. x 24 in. (610mm x 610mm)

Velocity (fpm)	Pressure Drop (in. wg)
500	0.03
1000	0.10
1500	0.21
2000	0.36
2500	0.54
3000	0.76
3500	1.01
4000	1.32

36 in. x 36 in. (914mm x 914mm)

Velocity (fpm)	Pressure Drop (in. wg)
500	0.03
1000	0.09
1500	0.18
2000	0.31
2500	0.46
3000	0.64
3500	0.86
4000	1.12

12 in. x 48 in. (305mm x 1219mm)

Velocity (fpm)	Pressure Drop (in. wg)
500	0.04
1000	0.11
1500	0.23
2000	0.39
2500	0.58
3000	0.81
3500	1.10
4000	1.43

48 in. x 12 in. (1219mm x 305mm)

Velocity (fpm)	Pressure Drop (in. wg)
500	0.03
1000	0.11
1500	0.22
2000	0.38
2500	0.57
3000	0.79
3500	1.06
4000	1.38

AMCA 5.3

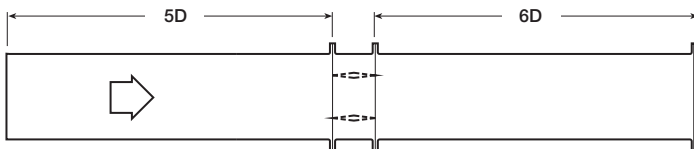

12 in. x 12 in. (305mm x 305mm)

Velocity (fpm)	Pressure Drop (in. wg)
500	0.04
1000	0.12
1500	0.24
2000	0.40
2500	0.60
3000	0.84
3500	1.12
4000	1.44

24 in. x 24 in. (610mm x 610mm)

Velocity (fpm)	Pressure Drop (in. wg)
500	0.03
1000	0.09
1500	0.17
2000	0.28
2500	0.43
3000	0.60
3500	0.80
4000	1.03

36 in. x 36 in. (914mm x 914mm)

Velocity (fpm)	Pressure Drop (in. wg)
500	0.03
1000	0.07
1500	0.14
2000	0.23
2500	0.35
3000	0.48
3500	0.64
4000	0.82

12 in. x 48 in. (305mm x 1219mm)

Velocity (fpm)	Pressure Drop (in. wg)
500	0.03
1000	0.10
1500	0.20
2000	0.34
2500	0.51
3000	0.72
3500	0.97
4000	1.26

48 in. x 12 in. (1219mm x 305mm)

Velocity (fpm)	Pressure Drop (in. wg)
500	0.03
1000	0.09
1500	0.19
2000	0.33
2500	0.50
3000	0.71
3500	0.96
4000	1.24

AMCA 5.5

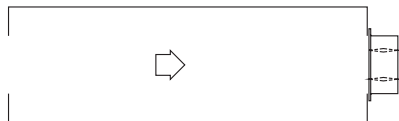

12 in. x 12 in. (305mm x 305mm)

Velocity (fpm)	Pressure Drop (in. wg)
500	0.07
1000	0.25
1500	0.54
2000	0.92
2500	1.41
3000	2.02
3500	2.73
4000	3.53

24 in. x 24 in. (610mm x 610mm)

Velocity (fpm)	Pressure Drop (in. wg)
500	0.05
1000	0.20
1500	0.41
2000	0.71
2500	1.10
3000	1.54
3500	2.09
4000	2.76

36 in. x 36 in. (914mm x 914mm)

Velocity (fpm)	Pressure Drop (in. wg)
500	0.05
1000	0.17
1500	0.36
2000	0.62
2500	0.96
3000	1.36
3500	1.84
4000	2.40

12 in. x 48 in. (305mm x 1219mm)

Velocity (fpm)	Pressure Drop (in. wg)
500	0.06
1000	0.20
1500	0.43
2000	0.74
2500	1.13
3000	1.59
3500	2.14
4000	2.78

48 in. x 12 in. (1219mm x 305mm)

Velocity (fpm)	Pressure Drop (in. wg)
500	0.05
1000	0.20
1500	0.42
2000	0.72
2500	1.11
3000	1.56
3500	2.12
4000	2.77