

All New!

EQB Mixed Flow Inline Fan

- **Lower initial cost** than traditional mixed flow fans
- **Higher efficiency and lower sound levels** than centrifugal and axial fans
- **Available with shorter lead times** than tubular inline fans



Model EQB
(Patent Pending)

Mixed flow fans are hybrid designs that combine the best axial and centrifugal properties into one fan. The new model EQB offers better air and sound performance than axial and centrifugal inline fans and is priced to fill a gap in the current market offering of inline fans.

Relative Cost and Efficiency Comparison

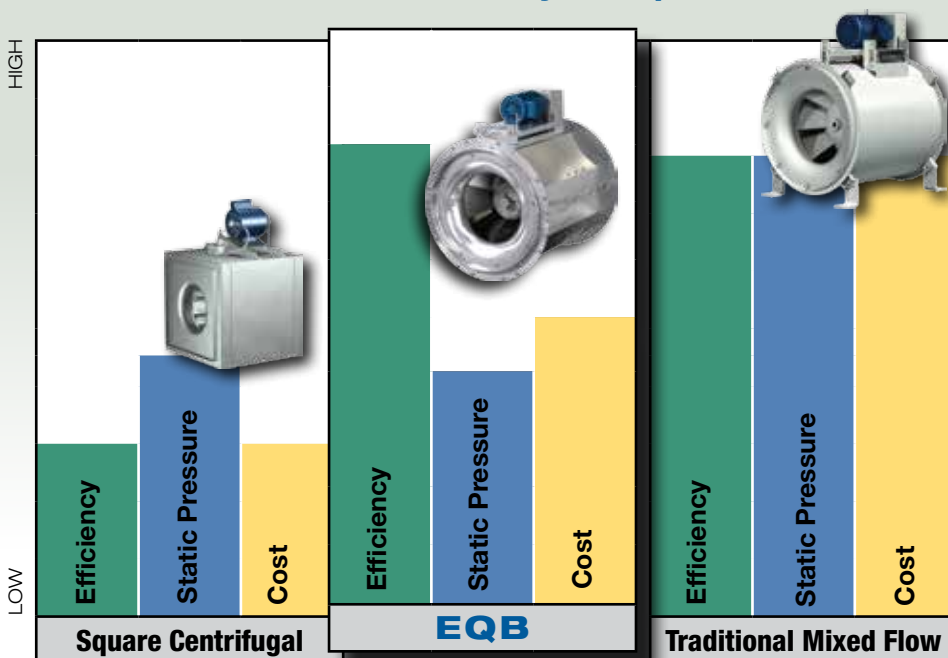

Indoor, commercial clean air applications include:

- Office Buildings
- Educational Facilities
- Libraries
- Hospitals
- Concert Halls
- Parking Garages

EQB Mixed Flow Inline, Belt Drive

Features

6 sizes:

12, 15, 18, 22, 27
and 30

Volume Range:

1,150 - 23,000 cfm

Static Pressure:

Up to 3 inches wg



Model EQB is licensed to bear the AMCA Seal.

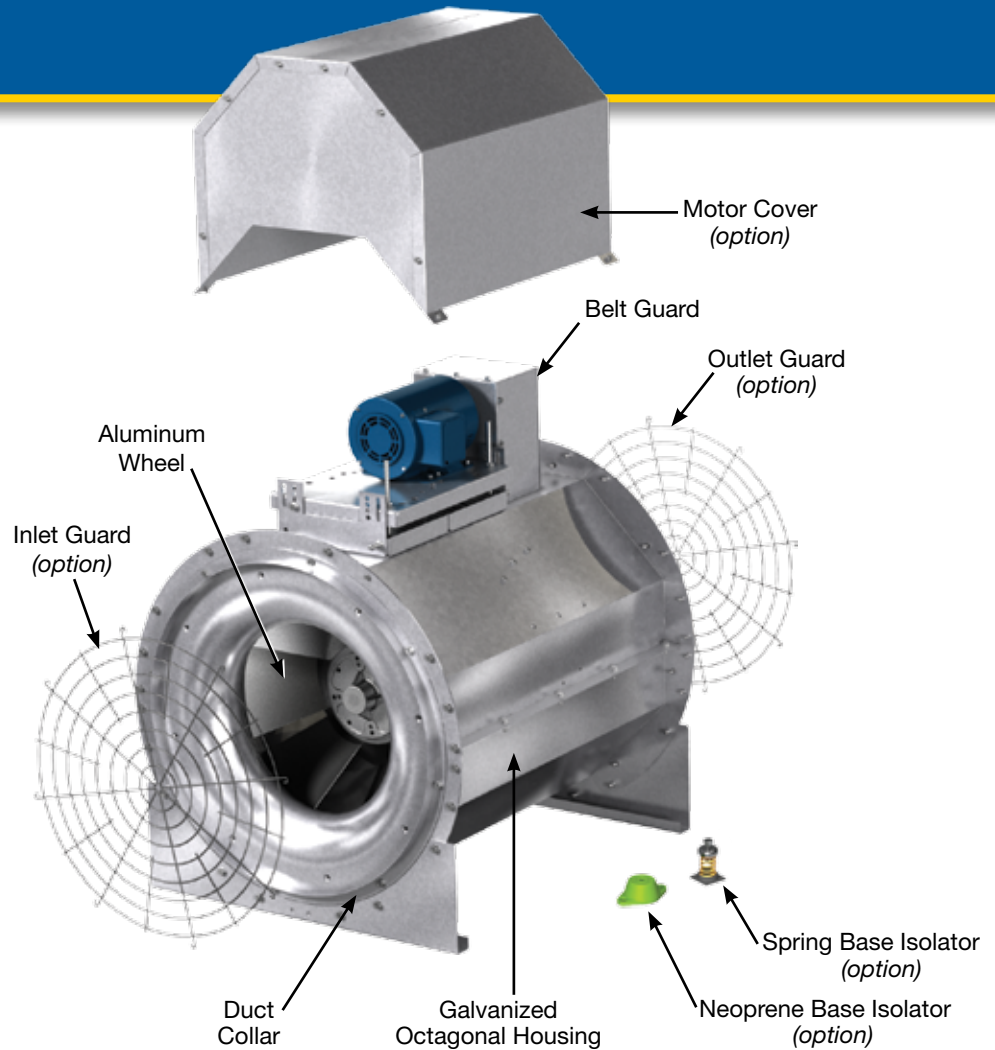

EQB Standard Features	Benefits
Octagonal housing	Better efficiency than traditional square housings at a lower cost than tubular housings, resulting in a fan that is competitive in the market
Galvanized housing	Rugged, lightweight, corrosion-resistant construction for long fan life
Aluminum mixed flow wheel	Quiet operation, lower operating costs, lightweight and durable
Universal mounting system	Field rotatable housing accommodates changes in fan mounting position and motor orientation as needed
Extended lubrication lines	Simplified bearing maintenance for reduced costs
Removable duct collars	Easy, slip-fit connection to ductwork
EZ-Tension System	Allows belt tensioning operations to be performed without external support for the weight of the motor.

