



Model FSDR-512

Combination Fire Smoke Damper

Round Steel Blade

UL 555S Leakage Class II

UL 555 1 1/2 Hour Fire Resistance Rating

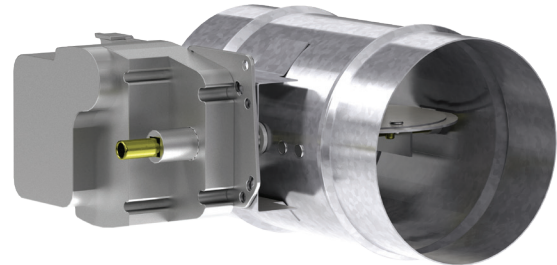

*Dimensions furnished approximately 1/8 in. (3mm) undersize.

Application

Model FSDR-512 is a combination fire smoke damper with round style blades. The FSDR-512 is qualified to 4,000 fpm (20.3 m/s) and 4 in. wg (1kPa) for operation and dynamic closure in emergency fire smoke situations. Model FSDR-512 may be installed vertically (with blades running horizontal) or horizontally and is rated for airflow and leakage in either direction.

Ratings

UL 555 Fire Resistance Rating

Fire Rating: 1 1/2 hour

Dynamic Closure Rating: Actual ratings are size dependent

Velocity: Up to 4,000 fpm (20.3 m/s)

Pressure: Up to 4 in. wg (1 kPa)

UL 555S Leakage Rating

Leakage Class: II

Operational Rating: Actual ratings are actuator dependent

Velocity: Up to 4,000 fpm (20.3 m/s)

Pressure: Up to 4 in. wg

Temperature: 350°F (177°C) - depending on actuator

Construction	Standard	Optional
Frame Material	Galvanized Steel	-
Frame Thickness	20 ga. (1mm)	16 ga. (1.5mm)
Blade Material	Double skin galvanized steel	-
Blade Thickness	14 ga. (2mm) equivalent	-
Blade Seal	Silicone	-
Axle Bearings	Bronze	316SS
Axle Material	1/2 in. (13mm) Plated Steel	-
Closure Device	Fusible Link	RRL, RRL/OCI, PRV, TOR
Closure Temperature	165°F (74°C)	212°F (100°C), 250°F (121°C), 286°F (141°C), 350°F (177°C)

Model FSDR-512 meets the requirements for fire dampers, smoke dampers and combination fire smoke dampers established by:

National Fire Protection Association
NFA Standards 80, 90A, 92, 101 & 105

IBC International Building Codes
CSFM California State Fire Marshal
Fire Damper Listing (#3225-0981:112)
Leakage (Smoke) Damper Listing (#3230-0981:113)

Underwriters Laboratories Standard 555
(Listing R13317)

Features and Options

- Electric or pneumatic actuators to accomplish smoke management and system functions
- One retainer plate required, additional retainer plate available
- OCI (Open Closed Indication switches)
- Momentary switch



See complete marking on product.

UL 555 and UL 555S
Classification R13317

Diameter	Minimum	Maximum
in. (mm)	6 in. (152)	24 in. (610)

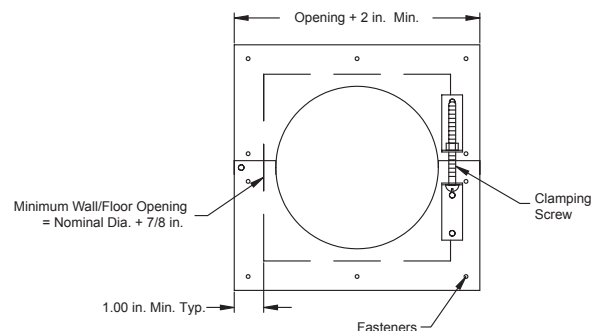

Installation instructions available at www.greenheck.com.

This pressure drop testing was conducted in accordance with AMCA Standard 500-D using the configuration shown. All data has been corrected to represent standard air at a density of .075 lb/ft³(1.201 kg/m³).

Actual pressure drop found in any HVAC system is a combination of many factors. This pressure drop information along with an analysis of other system influences should be used to estimate actual pressure losses for a damper installed in a given HVAC system.

AMCA Test Figures

Figure 5.3 illustrates a fully ducted damper. This configuration has the lowest pressure drop of the three test configurations because entrance and exit losses are minimized by straight duct runs upstream and downstream of the damper.

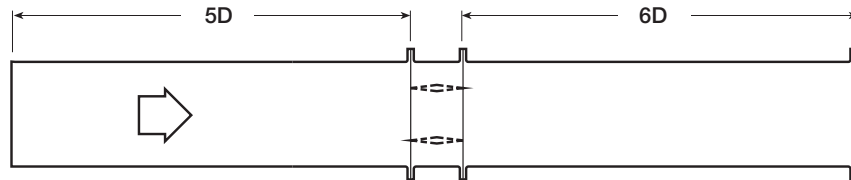
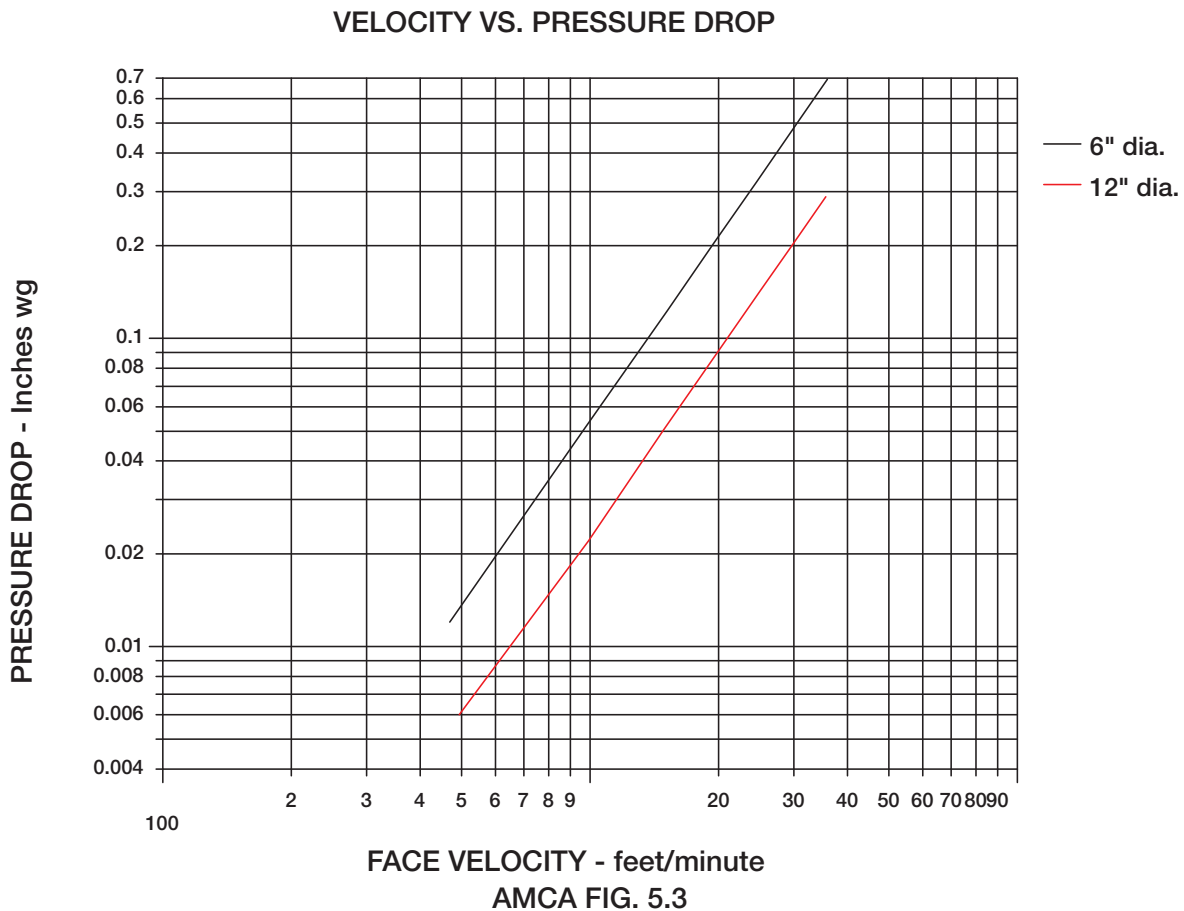
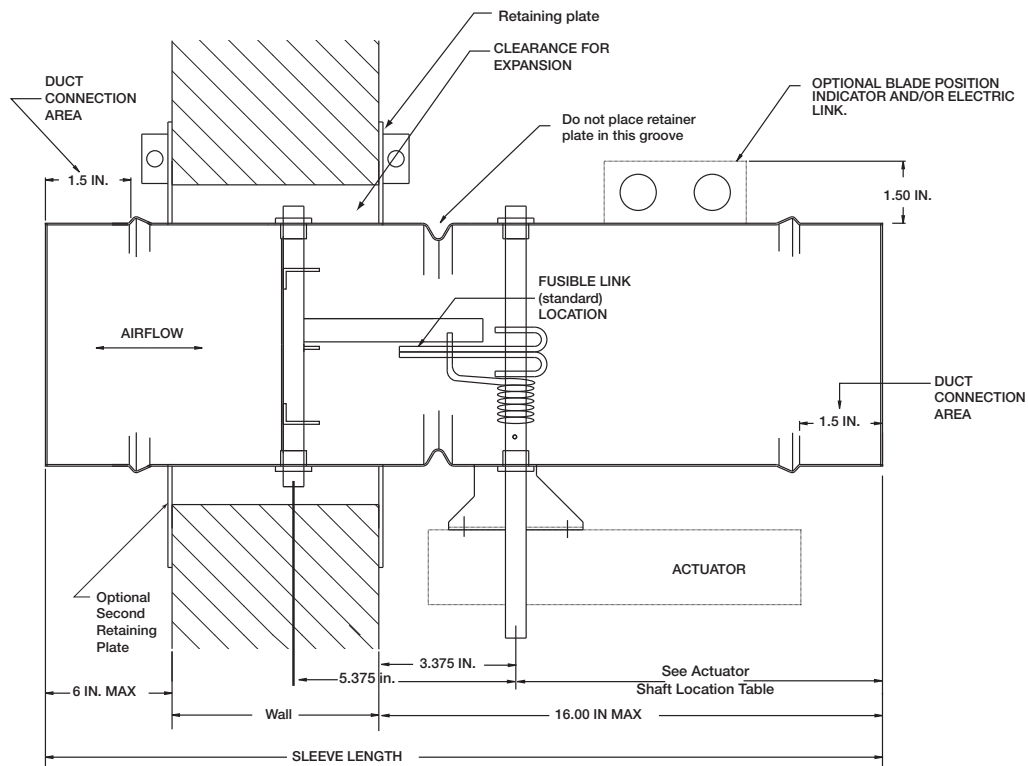

Figure 5.3





Actuator Shaft Location (in inches)				
Control Device	Diameter (in inches)			
	≥ 6 to $\leq 10\frac{1}{8}$	$>10\frac{1}{8}$ to $\leq 11\frac{1}{8}$	$>11\frac{1}{8}$ to $\leq 14\frac{1}{8}$	$>14\frac{1}{8}$
Fusible Link	$3\frac{1}{16}$	$3\frac{1}{16}$	$3\frac{1}{16}$	$3\frac{1}{16}$
RRL	$5\frac{11}{16}$	$4\frac{11}{16}$	$4\frac{11}{16}$	$4\frac{11}{16}$
RRL/OCI	$7\frac{7}{16}$	$7\frac{7}{16}$	$7\frac{7}{16}$	$7\frac{7}{16}$
TOR	$7\frac{7}{16}$	$7\frac{7}{16}$	$7\frac{7}{16}$	$7\frac{7}{16}$

Specifications

True round combination fire smoke dampers meeting the following specifications shall be furnished and installed where shown on plans and/or as described in schedules. Dampers shall meet the requirements of the latest edition of NFPA 80, 90A, 92, 101, and 105 and further shall be tested, rated and labeled in accordance with the latest edition of UL Standards 555 and 555S. Dampers shall have a UL555 fire rating of 1½ hours and be of low leakage design qualified to UL 555S Leakage Class II.

Each damper/actuator combination shall have a UL 555S elevated temperature rating of 250° F (121°C) minimum and shall be operational and dynamic rated to operate at maximum design air flow at its installed location. Each damper shall be supplied with an appropriate actuator installed by the damper manufacturer at the time of damper fabrication. Damper actuator shall be (specifier select one of the following) electric type for 120, 24, or 230 volt operation or pneumatic type for 25 psi minimum (30 psi maximum) operation.

Damper shall be constructed of 20 ga. (1mm) galvanized steel frame/sleeve; blade constructed of double skin galvanized steel round style blade; silicone rubber blade seal; ½ in. plated steel axles; bronze bearing. Damper is provided with one retainer plate.

Damper must be rated for mounting vertically (with blades running horizontal) or horizontally and be UL 555S rated for leakage and airflow in either direction through the damper. Each damper shall be supplied with a 165°F (74°C) fusible link. Testing and ratings to be in accordance with AMCA standard 500-D.

The basis of design is model FSDR-512.

