

Application

The HBTR-451 is an isolation damper designed for isolation and decontamination applications. The damper has bubble tight leakage performance per AMCA 500-D up to 30 in. wg (7.5 kPa). The damper frame is flanged for easy mounting and the blade seal is mechanically fastened to the blade.

Ratings

Velocity

6500 fpm (33 m/s)

Pressure

30 in. wg (7.5 kPa) - differential pressure

Leakage

Bubble tight per AMCA 500-D

Temperature*

-40 to 250°F (-40 to 121°C)

Construction

	Standard	Optional
Frame Depth (C)	See chart on page 2	
Frame Material	Painted steel	304SS, 316SS
Frame Type	Flanged Channel	
Frame Thickness	See chart on page 2	
Flange Width (D)	see chart on page 2	
Blade Material	Painted steel	304SS, 316SS
Blade Seals	Silicone rubber, field removable	
Blade Thickness	see chart on page 2	
Blade Type	Reinforced butterfly, field replaceable	
Blade Stop	Pin stop	
Axle Diameter	see chart on page 2	
Axle Bearings	Relubricable ball, outboard mounting	
Axle Material	Plated steel	303SS, 316SS
Axle Seals	Double gland stuffing box	
Paint Finishes	Hi Pro Polyester	Industrial Epoxy, Mill finish (304SS or 316SS)
Mounting Holes	None	On centerline, Straddle centerline

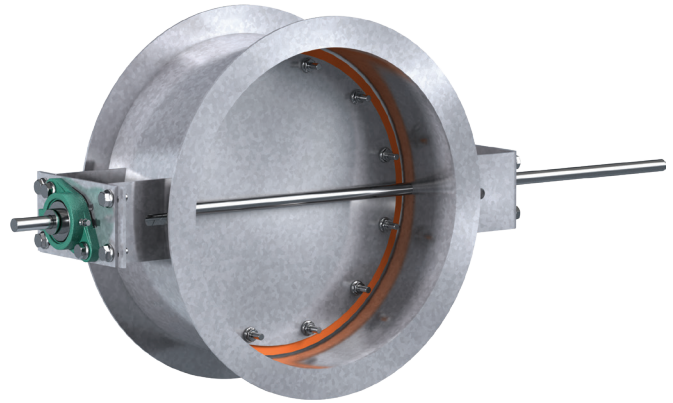

*Actual Inside Dimension

Size Limitations

W x H	Minimum Size	Maximum Size
Inches	6	48
mm	152	1219

Options:

- Mounting holes in flanges
- Actuators
- Limit switches
- Special construction
- Temperatures greater than 250°F (121°C), consult factory.

Dimensions

Diameter (D) Inches (mm)		Frame Depth J Inches (mm)	Frame & Flange gauge (mm)	Flange Width F Inches (mm)	Axle Diameter Inches (mm)	Blade Thickness gauge (mm)
Above	Through					
5.906 (150)	12 (305)	6 (152)	12 (2.7)	1.5 (38)	0.75 (19)	12 (2.7)
12 (305)	18 (457)	8 (203)	10 (3.5)	1.5 (38)	.75 (19)	10 (3.5)
18 (457)	24 (610)	8 (203)	10 (3.5)	1.5 (38)	1 (25)	10 (3.5)
24 (610)	27 (686)	8 (203)	.188 (4.8)	2 (51)	1 (25)	10 (3.5)
27 (686)	35 (889)	8 (203)	.188 (4.8)	2 (51)	1.25 (32)	10 (3.5)
35 (889)	39 (991)	8 (203)	.188 (4.8)	2 (51)	1.25 (32)	10 (3.5)
39 (991)	42 (1067)	8 (203)	.188 (4.8)	2 (51)	1.5 (38)	10 (3.5)
42 (1067)	48 (1219)	8 (203)	.25 (6)	2 (51)	1.5 (38)	.188 (4.8)

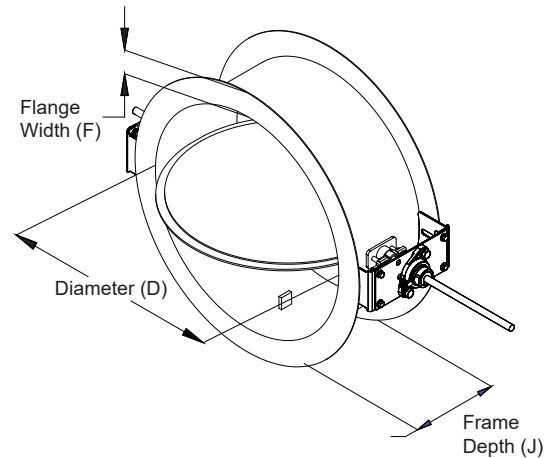

Mounting Holes

Standard - Does not include mounting holes

Optional - Bolt holes in both flanges

Greenheck recommended bolt hole pattern is shown in the table below. Customer must specify bolt holes that are parallel to the axle centerline (P) or that straddle the axle centerline (S) as shown in the diagrams below. Greenheck can also provide bolt hole sizes and patterns other than those shown below.

Greenheck Recommended Bolt Hole Pattern (Bolt Holes Parallel to Axle Centerline)					
Diameter Inches (mm)		Number of Holes	Mounting Hole Diameter in. (mm) N	Bolt Circle Diameter L	Degrees Between Holes
Above	Through				
6 (152)	8 (203)	4	$\frac{3}{8}$ (9.5)	*	90
8.001 (203)	18 (457)	8	$\frac{7}{16}$ (11)	*	45
18.001 (457)	24 (610)	12	$\frac{7}{16}$ (11)	*	30
24.001 (610)	36 (914)	16	$\frac{7}{16}$ (11)	*	22½
36.001 (914)	48 (1219)	24	$\frac{7}{16}$ (11)	*	15

* Bolt Circle Diameter = Damper Diameter + Flange Height + ¼ in. (6mm)

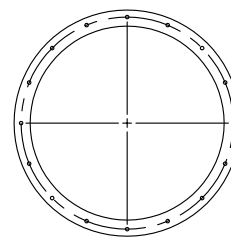
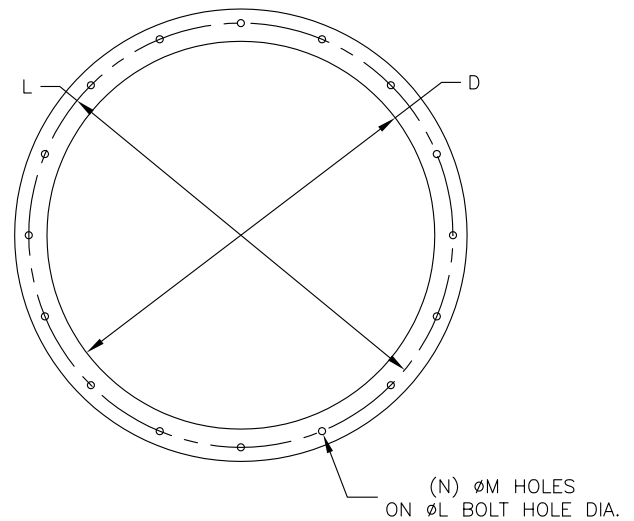

On Centerline

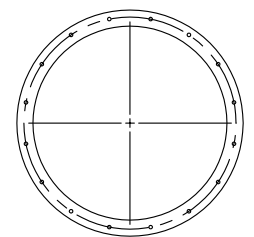

Straddle Centerline

Performance Data

Pressure Drop Data

This pressure drop data was conducted in accordance with AMCA 500-D using Test Figure 5.3. All data has been corrected to represent standard air at a density of 0.075 lb/ft³ (1.2 kg/m³).

Actual pressure drop found in any HVAC system is a combination of many factors. This pressure drop information along with an analysis of other system influences should be used to estimate actual pressure losses for a damper installed in a given HVAC system.

AMCA Test Figure 5.3

Figure 5.3 illustrates a fully ducted damper. This configuration has low pressure drop because entrance and exit losses are minimized by straight duct runs upstream and downstream of the damper.

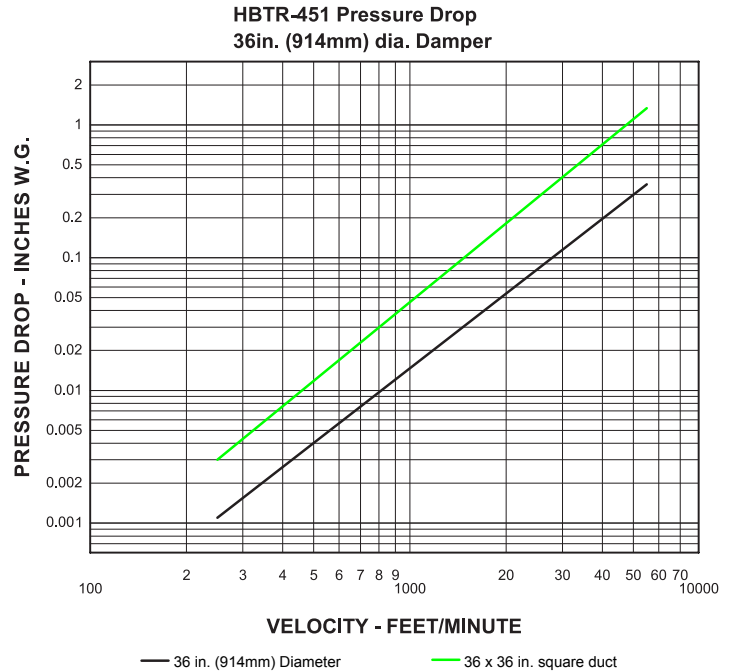
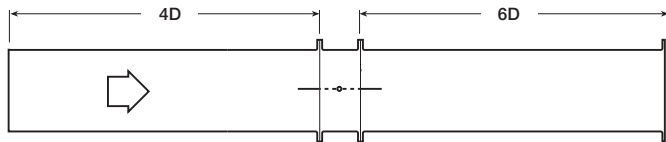

Leakage

Every HBTR-451 is leakage tested at 30 in. wg (7.5 KPa) in accordance with AMCA 500-D before it leaves the factory. Greenheck does not ship a HBTR-451 unless it meets the requirements of the standard.

Axle Seal Detail

The double gland axle seal is mounted externally for easy access and provides bubble tight performance.

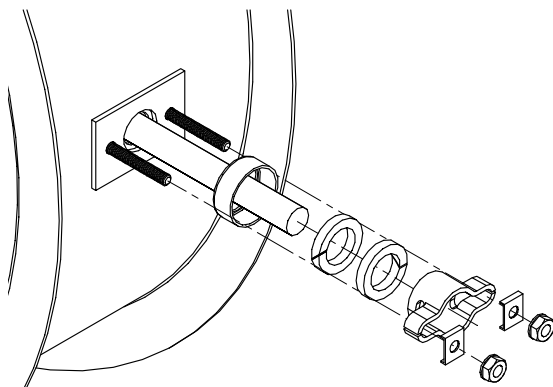

Bearing Detail

The ball bearings are mounted outboard for easy access. The bearing comes with a grease fitting, allowing for easy lubrication (axle seals included but not shown in bearing detail).

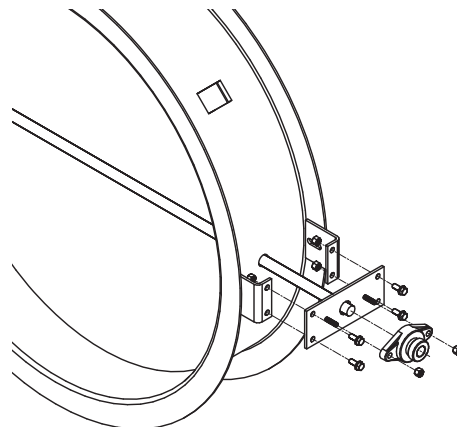



[INSTALLATION](#)



[TRI-FOLD](#)



[SUPPLEMENT
INFORMATION](#)



[CATALOG](#)



[SELECTION GUIDE](#)



[PRODUCT INFO](#)



[DAMPER SELECTION
GUIDE](#)



[SPECIFICATIONS](#)



[WARRANTY](#)