

Application

The IDHB series is a basic lower cost duct heater with limited sizes. The IDHB has the following standard features:

- UL 1996 certified
- 50/60 Hz compatibility
- Zero clearance
- Fan interlock
- Power and control terminal boards
- Automatic reset thermal safety switch for primary over temperature protection
- Manual reset thermal safety switch for secondary over temperature protection
- Heavy gage G60 construction with hinged access cover

Capacity and stages are dependent on voltage/phase and heater dimensions.

Capacity: 39.9 kw maximum

Construction

	Standard	Optional
Airflow Direction	Horizontal bi-directional	Vertical up
Contactors	Magnetic	-
Control Box Offset	Left	Right
Control Voltage	24 Vac	120 Vac
Element Wire	Standard	80/20
Heater Control	Stage	Pneumatic
Heater Type	Slip in	Flange
Heater Voltage/Phase	120/1	208/1, 208/3, 230/1, 230/3, 277/1, 460/1, 460/3, 480/1, 480/3
Material	Galvanized Steel	-
Recess (in.)	None	1, 2
Control Transformer	None	Fused, Unfused
Deration (kW)	None	.060, .045

Size Limitations

W x H	Minimum Size	Maximum Size	
		Slip in Heater	Flange Heater
Inches	8 x 8	36 x 36	35 x 34
mm	203 x 203	914 x 914	889 x 864

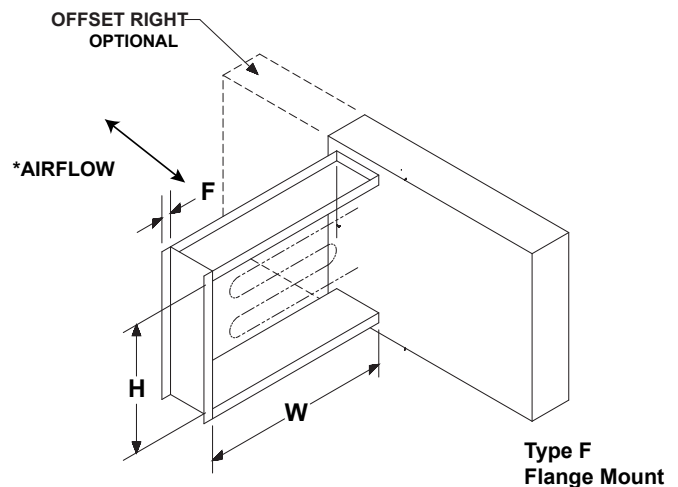
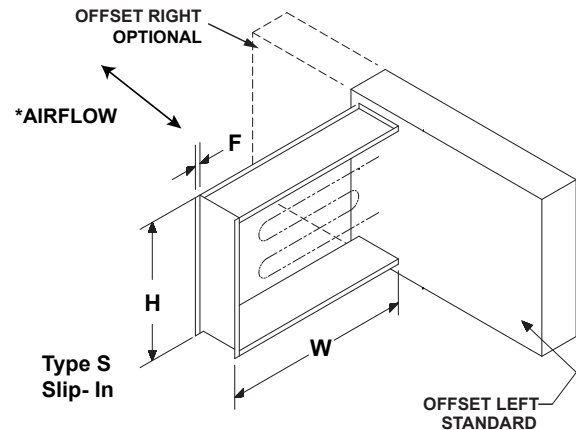

* Greenheck duct heaters are universally configured to allow airflow in either direction in horizontal ducts.

Options available:

- Airflow switch (adjustable/ fixed set point)
- Control transformer (fused/unfused)
- Disconnect switch with door interlock
- Dust tight box with gasketed door
- 80/20 element wire
- Room thermostat
- Vapor barrier
- De-rated coils
- Recess for internally insulated ducts
- Flush mount control cabinet for tight ceiling/floor installations
- Stainless steel hardware
- Right offset control cabinet
- PE (pressure electric) switch
- Pilot light
- Time delay relay - delay heater or delay stages

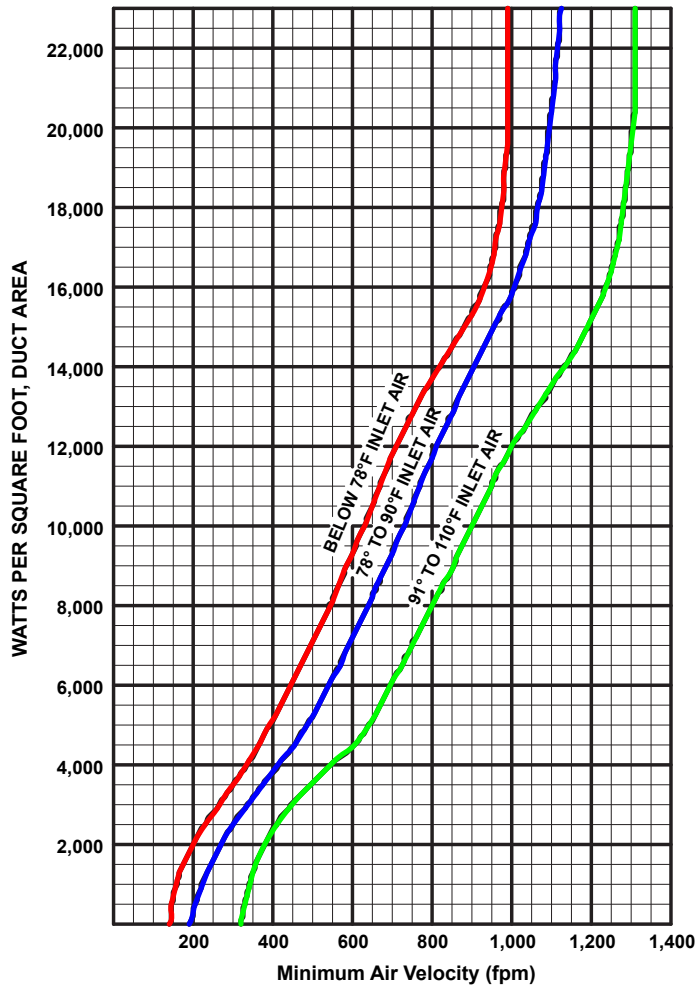

General

- A. The minimum airflow through a duct heater is directly related to the inlet air temperature. Consideration must be given to both airflow across the heater and the inlet temperature.
- B. To calculate the watts per sq. ft. (square foot) of duct area, divide the total watts required by the duct size (Watt density = watts/duct area (ft²)).

Example: Duct size equal 2 ft. x 3 ft., total watts equal 20,000 watts per sq. ft.

$$\frac{20,000}{6} = 3333$$

- C. If airflow in the duct is expressed in FPM, then a direct cross reference can be made by comparing the temperature of the air (as it enters the duct heater) to the kW rating on the table at the rated air velocity.
 1. Draw a line horizontally from the watts per sq. ft required to the inlet air temperature being used.
 2. From this point of intersection on the inlet temperature line, draw a line down vertically to establish the air velocity.
 3. In cases where the velocity is less than that determined from the chart, then the velocity must be increased, the kW required must be reduced, or both must be done.
- D. In cases where the airflow is expressed in CFM, convert to FPM by dividing the CFM by the duct area.

$$\frac{\text{CFM}}{\text{Duct Area(ft}^2\text{)}} = \text{FPM}$$

Document Links

[Duct Heater Trifold](#)



[Installation Instructions](#)



[Specifications](#)

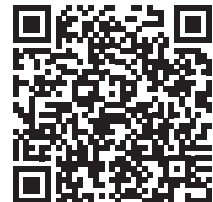

[Warranty](#)



[Damper Selection Guide](#)

