

Application

Model SMD-202 is a leakage rated smoke damper with 3V style blades. Model SMD-202 may be installed vertically (with blades running horizontally) or horizontally and is rated for airflow and leakage in either direction.

Ratings

UL 555S Leakage Rating

Leakage Class: II

Operational Rating: Actual ratings are size dependent

Velocity: Up to 2000 fpm (10.2 m/s)

Pressure: Up to 6 in. wg (1.5 kPa)

Temperature: Up to 350°F (177°C) - depending upon the actuator

Construction

	Standard
Frame Material	Galvanized steel
Frame Material Thickness	16 ga. (1.5mm)
Frame Type	5 in. x 1in. (127mm x 25mm) hat channel
Blade Material	Galvanized steel
Blade Material Thickness	16 ga. (1.5mm)
Blade Type	3V
Blade Action	Parallel
Linkage	Plated steel out of airstream, concealed in jamb
Axle Bearings	316SS
Axle Material	Plated steel
Blade Seals	Silicone
Jamb Seals	Stainless Steel

Note:

The frames are constructed with reinforced corners. Low profile head and sill are used on sizes less than 17 in. (432mm) high for lower pressure drop and improved damper performance.



W&H dimensions furnished approximately 1/4 in. (6mm) undersize. (Add sleeve thickness for overall sleeved damper dimension) Actuator is shown internal left.



See complete marking on product.

UL 555S Classification
R13317

Model SMD-201 meets the requirements for smoke dampers established by:

National Fire Protection Association
NFPA Standards 90A, 92, 101 & 105

IBC International Building Codes

CSFM California State Fire Marshal

Leakage (Smoke) Damper Listing (#3230-0981:104)

W x H	Minimum Size	Maximum Size	
		Single Section	Multiple Section
4 in. wg (1 kPa) pressure			
Inches	6 x 6	32 x 50 or 36 x 48	144 x 100 or 288 x 50
mm	152 x 152	813 x 1270 or 914 x 1219	3658 x 2438 or 7315 x 1270
6 in. wg (1.5 kPa) pressure			
Inches	6 x 6	36 x 48	144 x 48
mm	152 x 152	914 x 1219	3658 x 1219

Options

- [Breakaway connections](#)
- Clean wrap
- [Greenheck test switches \(GTS\)](#)
- [Grille tabs](#)
- [Momentary test switch](#)
- [Retaining angles](#)
- [OCI \(Open closed indication switches\)](#)
- Sealed transitions and sleeves
- [Security bars](#)
- Smoke detectors
- Transitions: C, O, R

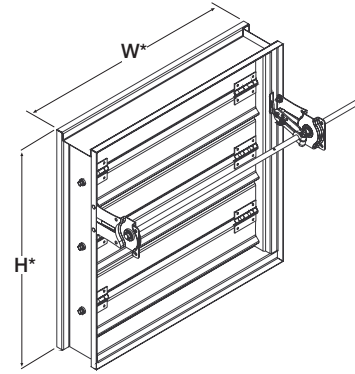

Document Links



[INSTALLATION](#)



[CATALOG](#)



[SELECTION GUIDE](#)



[SPECIFICATIONS](#)



[WARRANTY](#)

Pressure Drop

AMCA Figure 5.2

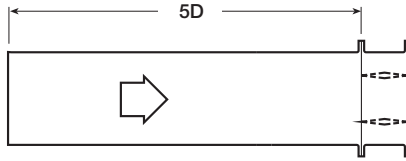

12 in. x 12 in. (305mm x 305mm)

Velocity (fpm)	Pressure Drop (in. wg)
500	0.04
1000	0.14
1500	0.31
2000	0.55
2500	0.86
3000	1.24
3500	1.69
4000	2.20

24 in. x 24 in. (610mm x 610mm)

Velocity (fpm)	Pressure Drop (in. wg)
500	0.02
1000	0.07
1500	0.16
2000	0.29
2500	0.45
3000	0.65
3500	0.89
4000	1.16

36 in. x 36 in. (914mm x 914mm)

Velocity (fpm)	Pressure Drop (in. wg)
500	0.01
1000	0.04
1500	0.09
2000	0.16
2500	0.25
3000	0.36
3500	0.49
4000	0.64

12 in. x 48 in. (305mm x 1219mm)

Velocity (fpm)	Pressure Drop (in. wg)
500	0.01
1000	0.06
1500	0.13
2000	0.23
2500	0.36
3000	0.52
3500	0.70
4000	0.92

48 in. x 12 in. (1219mm x 305mm)

Velocity (fpm)	Pressure Drop (in. wg)
500	0.03
1000	0.10
1500	0.23
2000	0.41
2500	0.63
3000	0.91
3500	1.24
4000	1.62

AMCA Figure 5.3

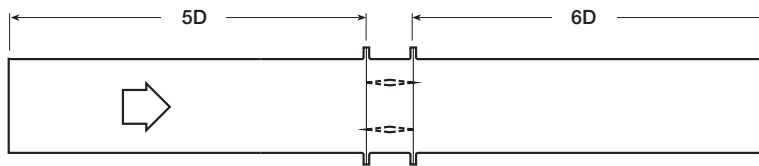

12 in. x 12 in. (305mm x 305mm)

Velocity (fpm)	Pressure Drop (in. wg)
500	0.02
1000	0.09
1500	0.20
2000	0.36
2500	0.56
3000	0.81
3500	1.10
4000	1.44

24 in. x 24 in. (610mm x 610mm)

Velocity (fpm)	Pressure Drop (in. wg)
500	0.01
1000	0.04
1500	0.09
2000	0.16
2500	0.25
3000	0.35
3500	0.48
4000	0.63

36 in. x 36 in. (914mm x 914mm)

Velocity (fpm)	Pressure Drop (in. wg)
500	0.01
1000	0.03
1500	0.06
2000	0.11
2500	0.17
3000	0.24
3500	0.33
4000	0.42

12 in. x 48 in. (305mm x 1219mm)

Velocity (fpm)	Pressure Drop (in. wg)
500	0.01
1000	0.04
1500	0.10
2000	0.17
2500	0.27
3000	0.39
3500	0.53
4000	0.70

48 in. x 12 in. (1219mm x 305mm)

Velocity (fpm)	Pressure Drop (in. wg)
500	0.02
1000	0.07
1500	0.16
2000	0.29
2500	0.45
3000	0.64
3500	0.88
4000	1.14

AMCA Figure 5.5

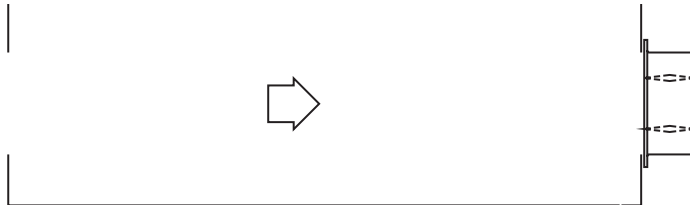

12 in. x 12 in. (305mm x 305mm)

Velocity (fpm)	Pressure Drop (in. wg)
500	0.06
1000	0.22
1500	0.50
2000	0.89
2500	1.39
3000	2.00
3500	2.72
4000	3.55

24 in. x 24 in. (610mm x 610mm)

Velocity (fpm)	Pressure Drop (in. wg)
500	0.03
1000	0.14
1500	0.31
2000	0.54
2500	0.85
3000	1.22
3500	1.66
4000	2.17

36 in. x 36 in. (914mm x 914mm)

Velocity (fpm)	Pressure Drop (in. wg)
500	0.03
1000	0.12
1500	0.26
2000	0.46
2500	0.73
3000	1.05
3500	1.42
4000	1.86

12 in. x 48 in. (305mm x 1219mm)

Velocity (fpm)	Pressure Drop (in. wg)
500	0.03
1000	0.13
1500	0.30
2000	0.53
2500	0.83
3000	1.19
3500	1.62
4000	2.11

48 in. x 12 in. (1219mm x 305mm)

Velocity (fpm)	Pressure Drop (in. wg)
500	0.04
1000	0.17
1500	0.38
2000	0.67
2500	1.04
3000	1.50
3500	2.05
4000	2.67



Greenheck Fan Corporation certifies that the model SMD-202 shown herein is licensed to bear the AMCA Seal. The ratings shown are based on tests and procedures performed in accordance with AMCA Publication 511 and comply with the requirements of the AMCA Certified Ratings Programs. The AMCA Certified Ratings Seal applies to air performance ratings only.

Space Envelopes

Externally mounted actuators always require space outside of the damper sleeve. The “S” dimension illustrates the clearance required for various available actuators.

Worst case space envelopes shown below. Exact dimensions may vary based on specific damper configuration. Consult factory for specific space envelope if necessary.

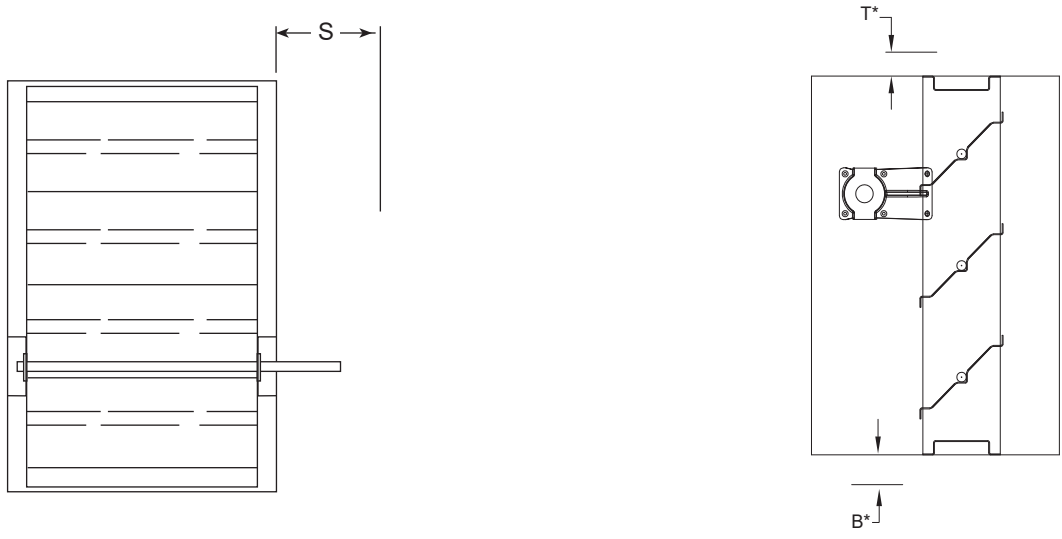

Actuator Type/Model	B*	T*	S	
	With RRL, RRL/OCI, or TOR	With RRL, RRL/OCI, or TOR	Piggyback	
			No	Yes
Belimo				
FSAFB24-SR (-S)	1½ in. (38mm)	9¼ in. (235mm)	6 in. (152mm)	9 in. (229mm)
FSLF series	8 in. (203mm)	1½ in. (38mm)	6½ in. (165mm)	NA
FSNF series	1½ in. (38mm)	9¼ in. (235mm)	6 in. (152mm)	9 in. (229mm)
FSTF Series	8 in. (203mm)	1½ in. (38mm)	6½ in. (165mm)	NA
Siemens				
GJD Series	7 in. (178mm)	1½ in. (38mm)	6½ in. (165mm)	NA
GRD Series	1½ in. (38mm)	7½ in. (191mm)	6½ in. (165mm)	NA
GXVD Series	1½ in. (38mm)	9¼ in. (235mm)	6 in. (152mm)	9 in. (229mm)
Honeywell				
MS4103, MS8103 Series	8¾ in. (222mm)	1½ in. (38mm)	6½ in. (165mm)	NA
MS4104, MS4604, MS8104 Series	1½ in. (38mm)	8½ in. (216mm)	6½ in. (165mm)	NA
MS4109, MS4609, MS8109 Series	1½ in. (38mm)	8½ in. (216mm)	6½ in. (165mm)	NA
MS4120, MS4620, MS8120 Series	1½ in. (38mm)	9½ in. (241mm)	6 in. (152mm)	9 in. (229mm)

* For dampers 18 in. (457mm) or more in height these dimensions are 0 in.

Contained Actuator Option

Dampers can be ordered with a “contained actuator option”. This option will result in the actuator being oriented such that it extends no more than 1½ inches above or below the sleeve. Note that some damper configurations that are 11 inches high or less will have the OCI mounted on the side opposite the actuator when the contained actuator option is selected.

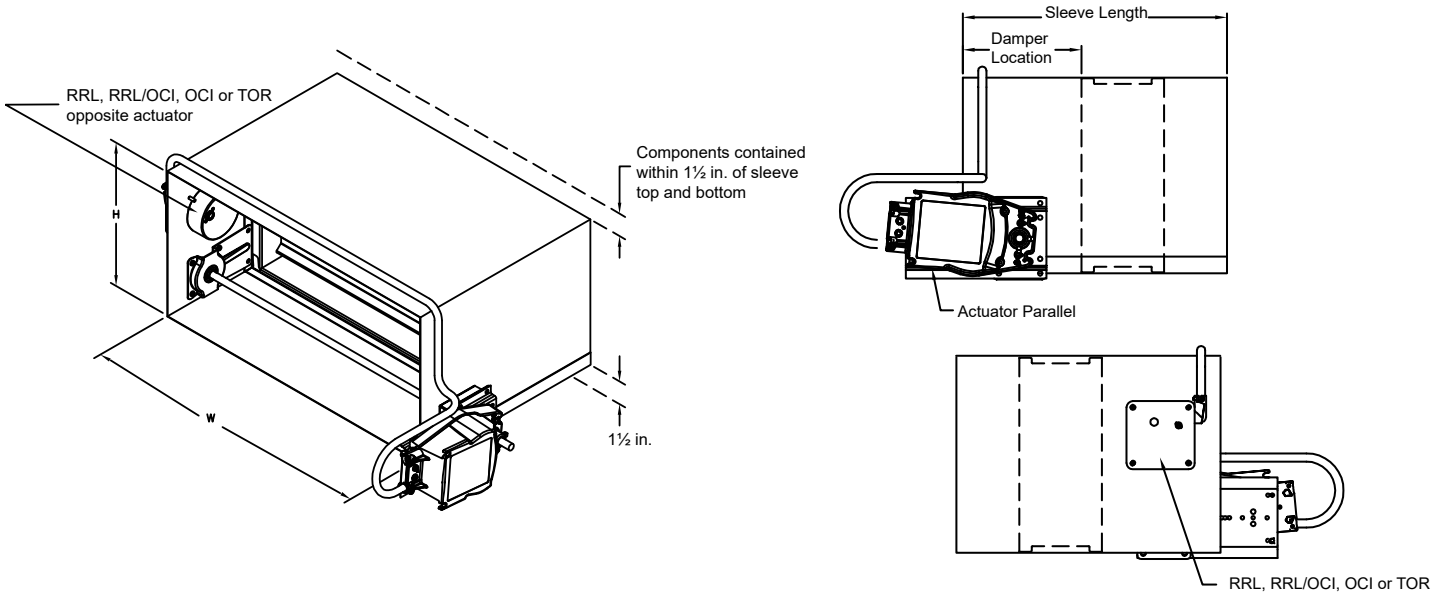

Sleeve and Sideplate Dimensions

The drawings below and corresponding table show the position of the SMD-202 damper when mounted in a factory sleeve ("A" dimension). The standard mounting locations provide enough space for the mounting of actuators, controls and allow space for installation of retaining angles and duct connections. The following options may affect the range of available mounting locations: smoke detector, NEMA 7 enclosure, transitions, security bars, grille tabs.

The standard location of a damper mounted in a factory sleeve ("A" dimension) is shown below. The damper can be positioned at other locations within a range of 6 in. (152mm) to 16 in. (406mm) for the "A" dimension.

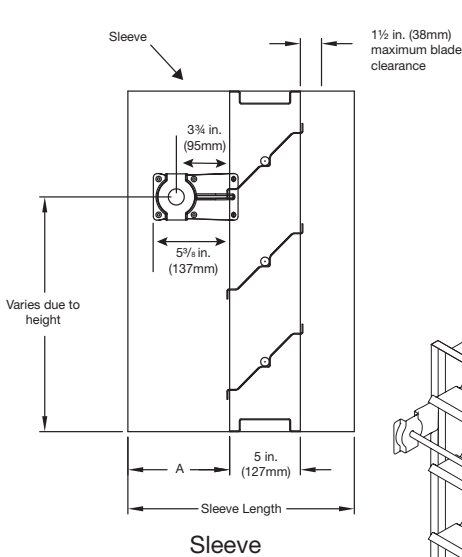

in. (mm)	With Sleeve		Sideplate Damper Location "A"
	Minimum Damper Location "A"	Maximum Damper Location "A"	
Dampers with no OCI	7 3/16 in. (183)	16 (406)	6 3/16 (157)
Height < 12 in. (305) OCI	12 (305)	16 (406)	12 (305)
Height ≥ 12 in. (305) OCI	7 3/16 in. (183)	16 (406)	12 (305)

NOTE: Entire damper frame is not required to be installed within the wall. The damper blades, when closed should be contained within the wall.

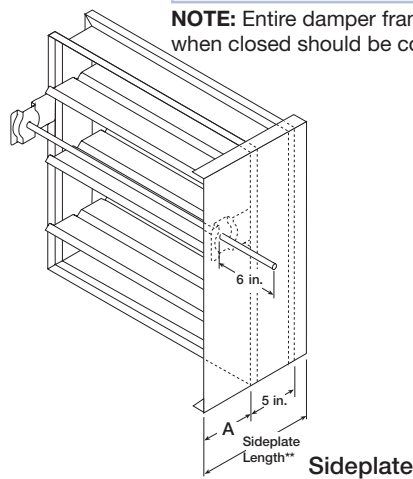

Transitioned Damper Dimensions

When a smoke damper is being used in conjunction with round or oval ductwork, the SMD-202 can be supplied in a factory sleeve with round or oval transitions on both ends of the sleeve. Dampers should be ordered to the duct dimensions. Drawings below show overall damper size.

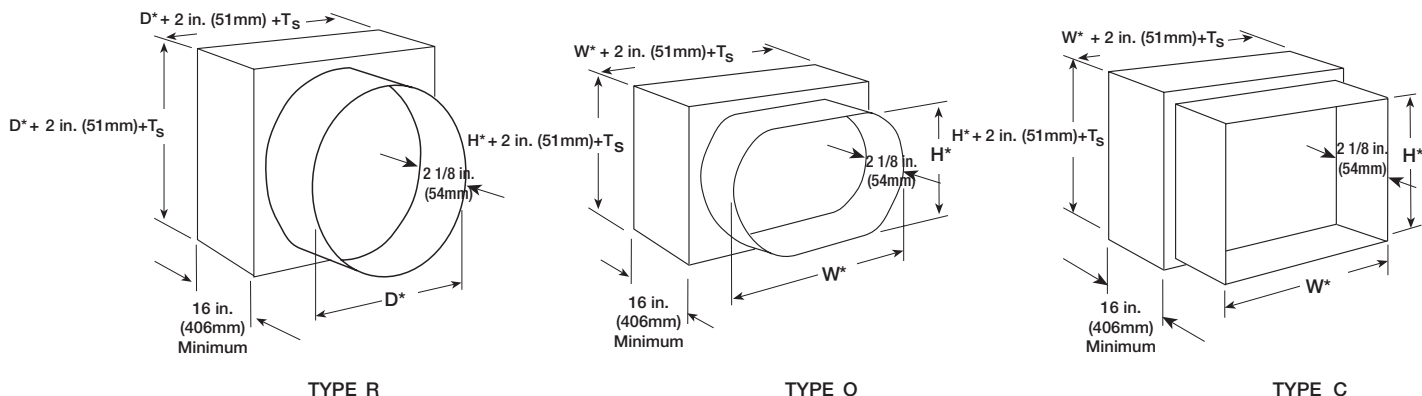

*These dimensions are furnished approximately 1/4 in. (6mm) undersize, except round and oval dimensions which are approximately 1/8 in. (3mm) undersize.

$T_s = (2)(\text{Sleeve Thickness})$

Multiple Section Dampers

Dampers larger than maximum single section size are supplied as a factory assembly of two or more sections of equal size. The following figures show maximum damper section size and assembly configurations for multi-section dampers.

