



MODEL SP-C50 CEILING/WALL VENTILATING FAN

READ AND SAVE THESE INSTRUCTIONS

WARNING

TO REDUCE THE RISK OF FIRE, ELECTRIC SHOCK, OR INJURY TO PERSONS, OBSERVE THE FOLLOWING:

1. Use this unit only in the manner intended by the manufacturer. If you have questions, contact the manufacturer at the address or telephone number listed in the warranty.
2. Before servicing or cleaning unit, switch power off at service panel and lock the service disconnecting means to prevent power from being switched on accidentally. When the service disconnecting means cannot be locked, securely fasten a prominent warning device, such as a tag, to the service panel.
3. Installation work and electrical wiring must be done by a qualified person(s) in accordance with all applicable codes and standards, including fire-rated construction codes and standards.
4. Sufficient air is needed for proper combustion and exhausting of gases through the flue (chimney) of fuel burning equipment to prevent backdrafting. Follow the heating equipment manufacturer's guideline and safety standards such as those published by the National Fire Protection Association (NFPA), and the American Society for Heating, Refrigeration and Air Conditioning Engineers (ASHRAE), and the local code authorities.

WARNING

5. When cutting or drilling into wall or ceiling, do not damage electrical wiring and other hidden utilities.
6. Ducted fans must always be vented to the outdoors.
7. This unit may be used over a tub or shower enclosure when installed in a GFCI protected branch circuit.
8. If this unit is to be installed over a tub or shower, it must be marked as appropriate for the application.
9. Never place a switch where it can be reached from a tub or shower.

CAUTION

1. For general ventilating use only. Do not use to exhaust hazardous or explosive materials and vapors.
2. To avoid motor bearing damage and noisy and/or unbalanced impellers, keep drywall spray, construction dust, etc. off power unit.
3. Please read specification label on product for further information and requirements.

INSTALLATION

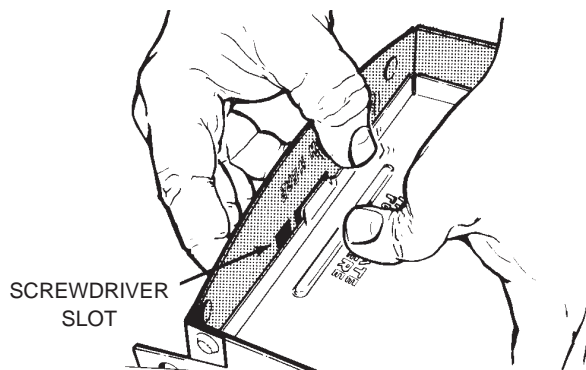

1. Remove motor plate from housing by pushing down on rib in plate while pulling out on side of housing. Motor plate may also be removed by inserting a straight-blade screwdriver into slot in housing and twisting screwdriver.

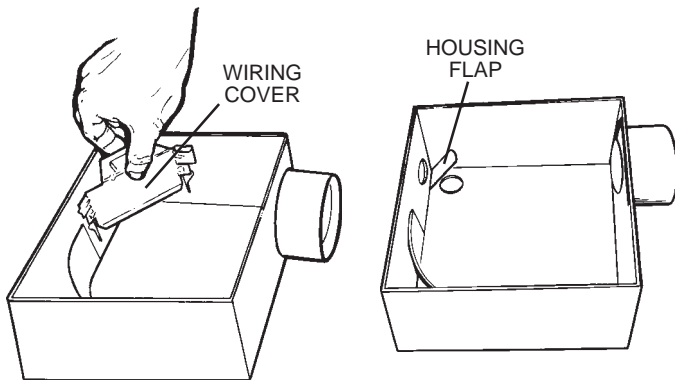

2. Remove wiring cover from housing by pulling straight out. Unit is shipped ready to wire through the top of housing. To wire through the side, bend housing flap to cover top hole and expose side hole. **DO NOT BREAK OFF FLAP.** If flap breaks, plug unused hole using standard electrical hole plug.
3. **Turn off electrical power at service entrance** and connect power cable to housing using appropriate connector. Wire black to black, white to white, and green to green or bare wire.

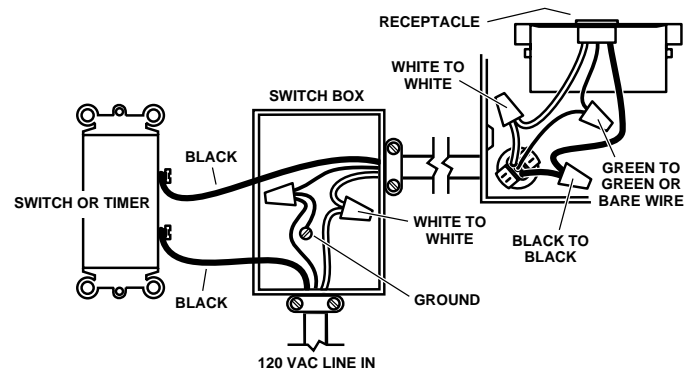

Push all wiring up into corner of unit and replace wiring cover. Make sure cover holds housing flap in place against side or top of housing. **CAUTION: DO NOT ALLOW WIRES TO EXTEND OUTSIDE OF WIRING BOX. Wire left exposed will become pinched or cut when motor plate is installed. Electrical shock may result.**

4. Choose the location for your fan. For best performance, use the shortest possible duct run and a minimum number of elbows. For wall installations: Position unit so damper flap closes when unit is off.

5. New installation prior to finishing the ceiling or wall:

MAKE SURE HOUSING WILL BE FLUSH WITH FINISHED CEILING OR WALL. Slotted tabs are provided to locate housing flush with 1/2" ceiling or wall material. Bend tabs outward 90° (use a screwdriver if desired) and position housing so that tabs rest against bottom edge of joists (or front of stud). Nail housing to joist or stud using four nails to ensure a solid, quiet installation. **Ceiling installations:** Tabs on opposite side of housing can be bent outward to rest on top of 1/2" ceiling material and provide extra stability.

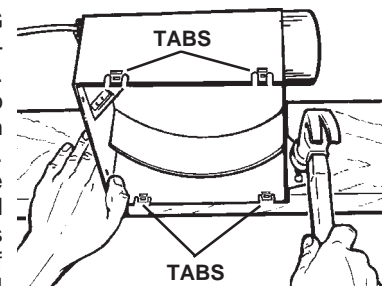

5. Replacement installation:

Position housing so that it is centered in existing opening. **MAKE SURE HOUSING IS FLUSH WITH FINISHED CEILING OR WALL.** After making electrical and ductwork connections (see steps 4, 5 and 6), nail housing in place. Drive nails through the housing where indicated by arrows.

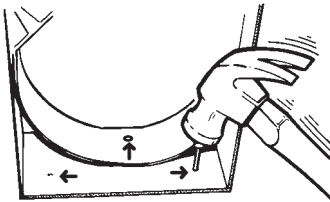

5. New installation in an existing ceiling or wall:

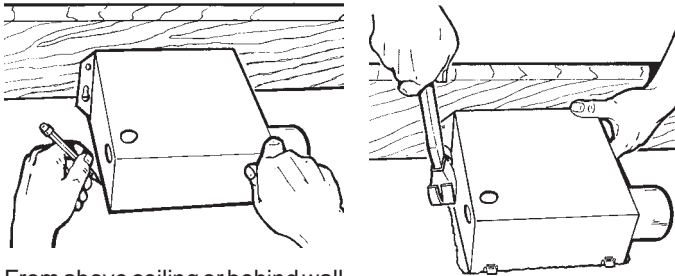

From above ceiling or behind wall, position housing against stud or joist. Trace outline of housing on ceiling or wall material. Set housing aside and cut opening. Place housing in opening such that its **BOTTOM EDGE IS FLUSH WITH FINISHED CEILING OR WALL.** 1/2" ceiling or wall material: Bend tabs outward 90° (use a screwdriver if desired) to rest on top of ceiling or wall material and provide extra stability. Nail in place using four nails to ensure a solid, quiet installation.

6. Install 3" round duct onto damper/duct connector. If rigid ductwork is used, its seam should be positioned at top of damper/duct connector. Tape the joint and extend ducting to a wall cap or roof cap. Make sure the damper operates freely. Ceiling or wall can now be finished.

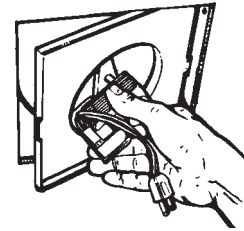

7. Replace the motor plate removed in Step 1. Insert two motor plate tabs into slots in housing and then pivot motor plate up until the third tab on plate snaps into matching slot in housing. Make sure tabs hold motor plate securely in place. Plug in motor.

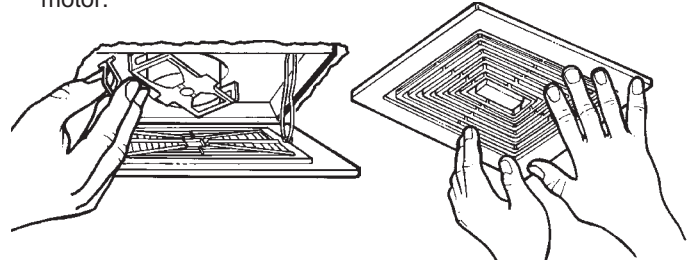

8. Squeeze grille springs together and insert springs into slots in motor plate. Push grille up against ceiling or wall.

SERVICE PARTS

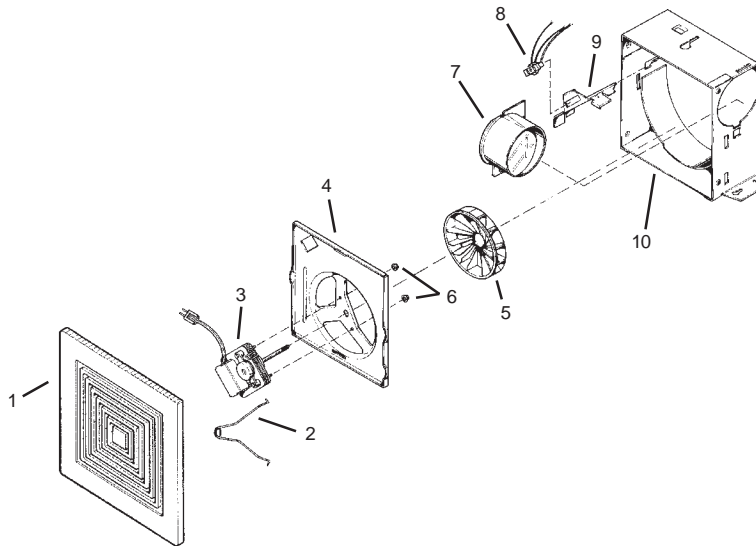

KEY NO.	PART NUMBER	DESCRIPTION
1	97011723	Grille Assembly (Includes Key Nos 1 & 2)
2	99140187	Grille Spring (2 Required)
3	99080254	Motor
4	98006791	Motor Plate
5	99110655	Blower Wheel
6	99260428	Nut #6-32 (2 Required)
7	97008632	Damper/Duct Connector
8	99271252	Receptacle
9	98006773	Wiring Cover
10	97008319	Housing Assembly

Greenheck warrants this equipment to be free from defects in material and workmanship for a period of one year from the purchase date.

Any units or parts which prove to be defective during the warranty period will be repaired or replaced at our option when returned to the factory, transportation prepaid.

Greenheck Fan Corporation will not be responsible for any installation or removal costs.

Greenheck Fan Corporation
 P.O. Box 410
 Schofield, Wisconsin 54476-0410
 (715) 359-6171