

Application and Design

Model HBR-050 is a light duty round industrial backdraft damper with a flanged style frame. It allows air to be drawn into a draft relief application or to prevent backflow in an HVAC or a process application. A variety of optional features makes model HBR-050 extremely versatile.

Ratings

Pressure: Up to 6 in. wg (1.5 kPa) - differential pressure

Velocity: Up to 3000 fpm (15.2 m/s)

Temperature: Up to 250°F (121°C)



*Actual inside dimension

Features

- Wide mounting flanges can be ordered with bolt holes, customized to match your requirements.

	Standard	Optional
Frame Material	Galvanized Steel	Painted, 304SS, or 316SS
Frame Type	Flanged Channel	
Blade Material	Galvanized Steel	Painted, 304SS, or 316SS
Blade Seals	None	-
Blade Stop	Pin Stop	-
Blade Type	Round	
Axle Bearing	Galvanized Steel Ball	-
Axle Material	Plated Steel	316SS
Paint Finishes	Mill Finish	Hi Pro Polyester
Air Flow	Horizontal	Vertical Up, Vertical Down

Diameter	Minimum Size	Maximum Size
Inches	7 1/4	24
mm	184	610

Diameter <i>D</i> Inches (mm)		Frame Depth <i>J</i> Inches (mm)	Frame & Flange Gauge (mm)	Flange Width <i>F</i> Inches (mm)	Square Axle Inches (mm)	Blade Thickness Gauge (mm)
Above	Through					
7 1/4 (184)	12 (305)	6 (152)	14 (2)	1.25 (32)	0.375 (9.5)	16 (1.5)
12 (305)	18 (457)	8 (203)	14 (2)	1.5 (32)	0.375 (9.5)	16 (1.5)
18 (457)	24 (610)	8 (203)	14 (2)	1.5 (32)	0.375 (9.5)	16* (1.5)

* with reinforcements

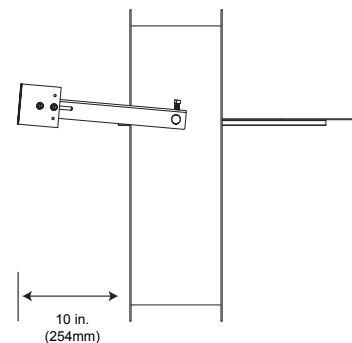

Blade open

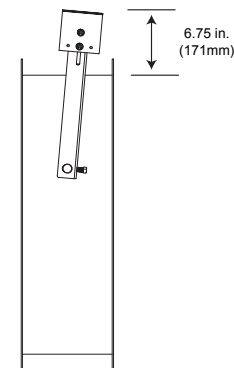

Blade close

Advise air flow direction & counterbalance weight location when ordering

AMCA Test Figure 5.3

Figure 5.3 illustrates a fully ducted damper. This configuration has low pressure drop because entrance and exit losses are minimized by straight duct runs upstream and downstream of the damper.

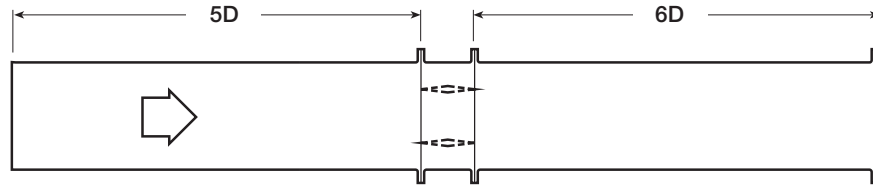

Pressure Drop Data

This pressure drop data was conducted in accordance with AMCA Standard 500-D using Test Figure 5.3. All data has been corrected to represent standard air at a density of 0.075 lb./ft³ (1.2 kg/m³).

Actual pressure drop found in any HVAC system is a combination of many factors. This pressure drop information along with an analysis of other system influences should be used to estimate actual pressure losses for a damper installed in a given HVAC system.

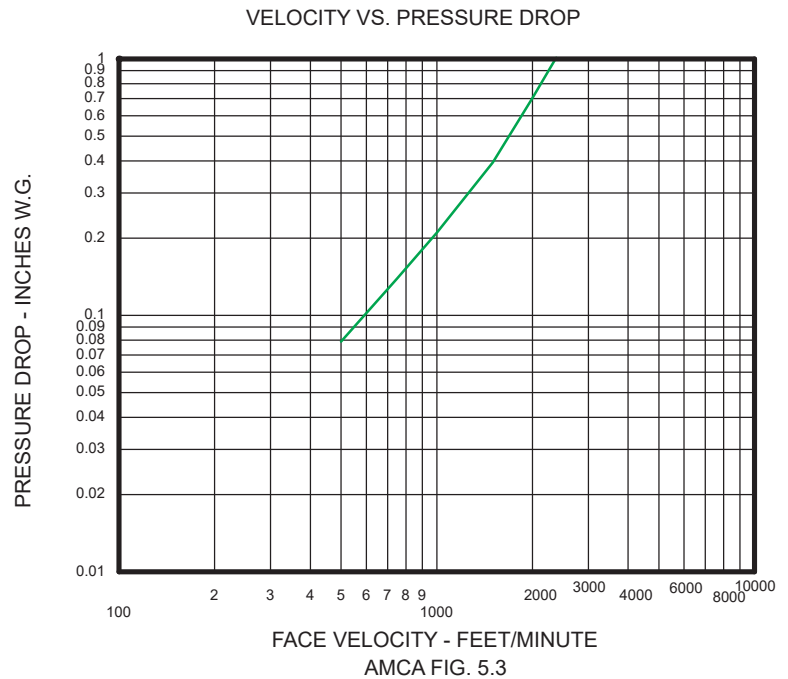

Leakage Data

Damper leakage (with blade fully closed) varies based on the type of blade stops and low leakage seals applied. Model HBR-050 is available with no seals. Leakage testing was conducted in accordance with AMCA Standard 500-D and is expressed as cfm/ft² of damper face area. All data has been corrected to represent standard air at a density of 0.075 lb/ft³ (1.2 kg/m³).

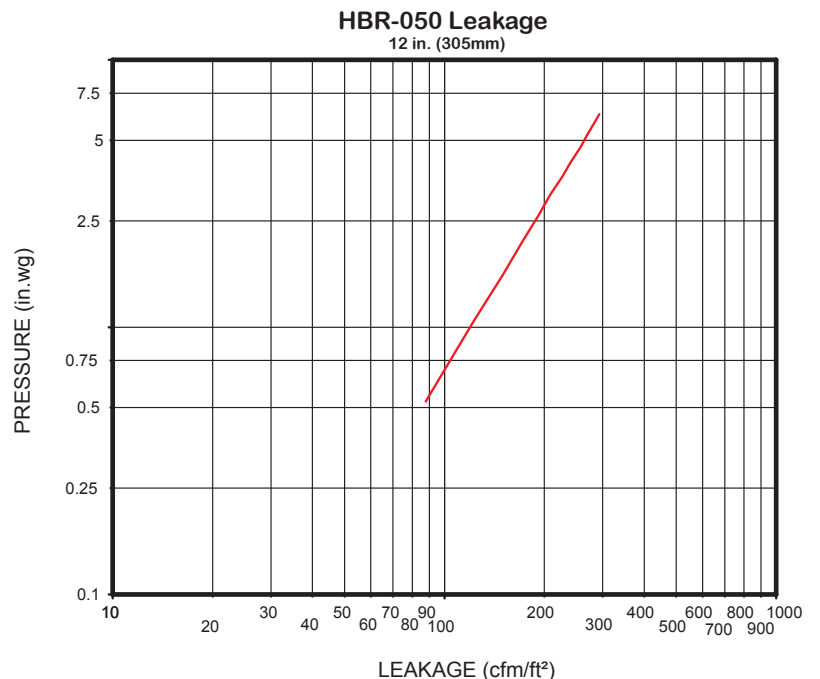

Bolt Holes

The recommended bolt hole pattern is shown in the table below. Customer must specify bolt holes that are parallel to the axle centerline or that straddle the axle centerline as shown in the diagrams below. The factory can also provide bolt hole sizes and patterns other than those shown.

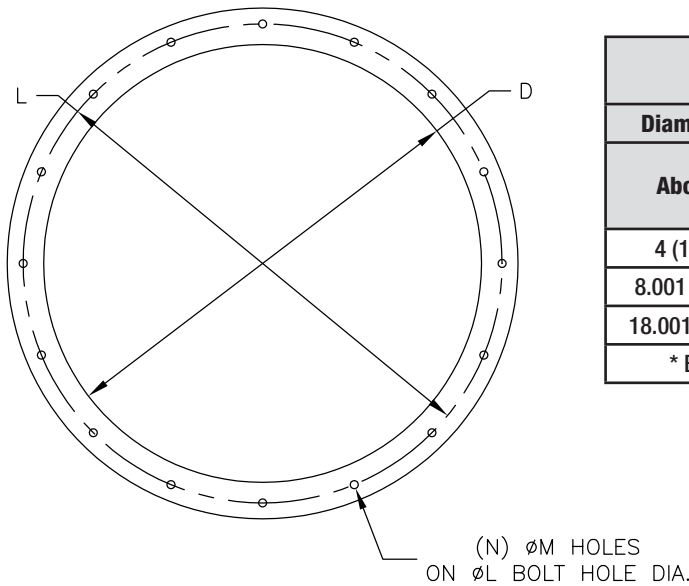

Recommended Bolt Hole Pattern (Bolt Holes Parallel to Axle Centerline)					
Diameter Inches (mm)		Number of Holes	Mounting Hole Diameter in. (mm) N	Bolt Circle Diameter L	Degrees Between Holes
Above	Through				
4 (102)	8 (203)	4	3/8 (9.5)	*	90
8.001 (203)	18 (457)	8	7/16 (11)	*	45
18.001 (457)	24 (610)	12	7/16 (11)	*	30
* Bolt Circle Diameter = Damper Diameter + Flange Height + 1/4 in. (6mm)					

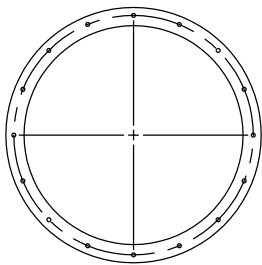

On Centerline

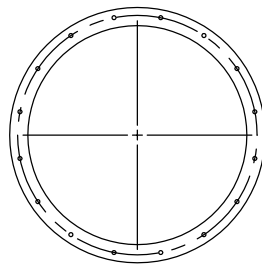

Straddle Centerline

Specifications

Industrial grade backdraft dampers meeting the following specifications shall be furnished and installed where shown on plans and/or as described in schedules.

Dampers shall consist of a round channel frame, single axle, and single circular blade fabricated from steel. Damper axle shall pivot in galvanized steel ball bearing pressed into each side of the damper frame and external (out of the airstream) heavy duty counterbalance weights.

Damper manufacturer's printed application and performance data include pressure, velocity and temperature limitations shall be submitted for approval showing damper suitable for pressures up to 6 in. wg (1.5 kPa), velocities to 3000 fpm (15.2 m/s) and temperature to 250°F (121°C). Testing and ratings to be in accordance with AMCA Standard 500-D.

Basis of design is HBR-050.

