

## Application

Model HCDR-152 is a heavy duty two-blade round industrial control damper with a flanged style frame. This damper provides a more precise control of the airstream through blade modulation. A variety of optional features makes the model HCDR-152 extremely versatile, allowing its capabilities to be tailored to your application.

## Ratings

<b>Pressure</b>
Up to 6 in. wg (1.5 kPa) differential pressure
<b>Velocity</b>
Up to 4000 fpm (20.3 m/s)
<b>Temperature</b>
-40° to 400°F (-40 to 205°C) maximum

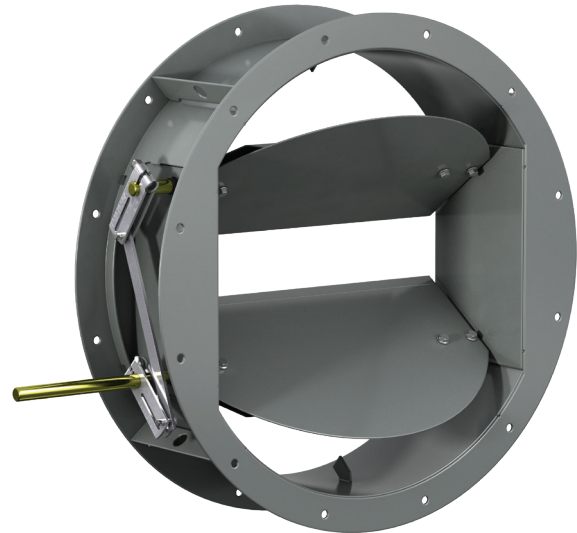

\* actual inside dimension

## Construction

	Standard	Optional
<b>Frame Material</b>	Painted	304SS or 316SS
<b>Frame Type</b>	Flanged Channel	
<b>Blade Action</b>	Opposed	-
<b>Blade Material</b>	Painted	304SS or 316SS
<b>Blade Seals</b>	None	EPDM, Silicone
<b>Blade Stop</b>	Pin Stop	Rolled Bar
<b>Blade Type</b>	Single Thickness	
<b>Axle Bearing</b>	Stainless steel sleeve	External Bronze
<b>Axle Material</b>	Plated Steel	303SS or 316SS
<b>Linkage</b>	Plated Steel	-
<b>Axle Seals</b>	None	O-ring
<b>Linkage</b>	Plated Steel	304SS, 316SS
<b>Paint Finishes</b>	Hi Pro Polyester	Hi Temperature Flame Control, Hi Temperature Silver, Industrial Epoxy, None

Diameter	Minimum Size	Maximum Size
Inches	12	48
mm	305	1219

## Bearing and Shaft Options

---

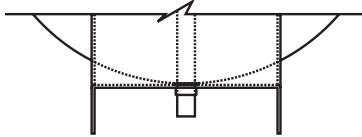

Stainless Steel  
Sleeve Bearing  
(Standard)

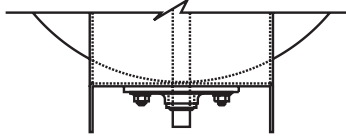

External Mounted  
Bronze Sleeve Bearing  
(Optional)

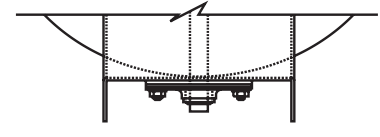

External Mounted  
Bronze Sleeve Bearing  
with O-Ring  
(Optional)

## Document Links

---

[Installation Instructions](#)

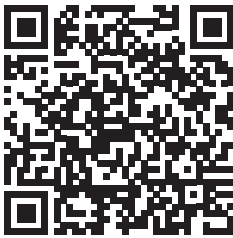

[Heavy Duty Industrial Catalog](#)



[Damper Product Selection Guide](#)



[Heavy Duty Industrial Product Selection](#)



[Damper Warranty](#)



# Dimensions

Diameter D Inches (mm)		Frame Depth J Inches (mm)	Frame & Flange Gauge (mm)	Flange Width F Inches (mm)	Axle Diameter Inches (mm)	Blade Thickness Gauge (mm)
Above	Through					
11.99 (305)	20 (508)	8 (203)	12 (2.7)	1.5 (32)	0.75 (19)	16 (1.5)
20 (508)	24 (610)	8 (203)	10 (3.5)	1.5 (32)	0.75 (19)	14 (2)
24 (610)	36 (914)	8 (203)	10 (3.5)	2.0 (51)	0.75 (19)	14 (2)
36 (914)	48 (1219)	8 (203)	10 (3.5)	2.0 (51)	1.00 (25)	14 (2)

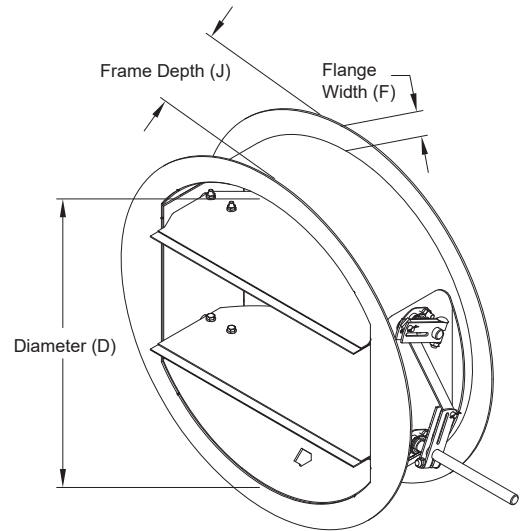

## Bolt Holes

The recommended bolt hole pattern is shown in the table below. Customer must specify bolt holes that are parallel to the axle centerline or that straddle the axle centerline as shown in the diagrams below. The factory can also provide bolt hole sizes and patterns other than those shown.

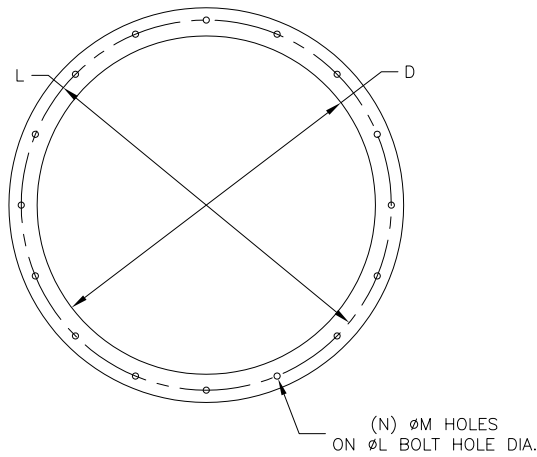

Recommended Bolt Hole Pattern (Bolt Holes Parallel to Axle Centerline)					
Diameter Inches (mm)		Number of Holes	Mounting Hole Diameter in. (mm) N	Bolt Circle Diameter L	Degrees Between Holes
Above	Through				
11.99 (305)	18 (457)	8	7/16 (11)	*	45
18.001 (457)	24 (610)	12	7/16 (11)	*	30
24.001 (610)	36 (914)	16	7/16 (11)	*	22 1/2
36.001 (914)	58 (1473)	24	7/16 (11)	*	15
58.001 (1473)	72 (1829)	32	9/16 (14)	*	11 1/4
* Bolt Circle Diameter = Damper Diameter + Flange Height + 1/4 in. (6mm)					

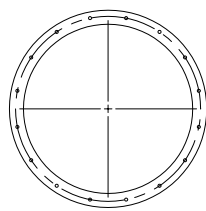
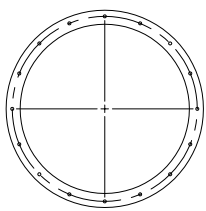

# Pressure Drop Data

## AMCA Test Figure 5.3

Figure 5.3 illustrates a fully ducted damper. This configuration has low pressure drop because entrance and exit losses are minimized by straight duct runs upstream and downstream of the damper.

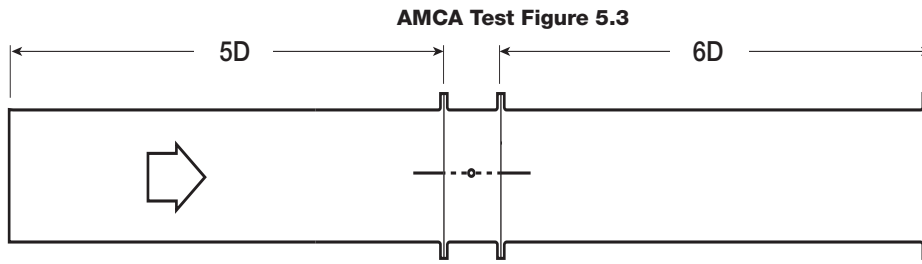

This pressure drop data was conducted in accordance with AMCA Standard 500-D using Test Figure 5.3. All data has been corrected to represent standard air at a density of 0.075 lb/ft<sup>3</sup> (1.2 kg/m<sup>3</sup>).

Actual pressure drop found in any HVAC system is a combination of many factors. This pressure drop information along with an analysis of other system influences should be used to estimate actual pressure losses for a damper installed in a given HVAC system.

## Back to Front with the bar stops upstream

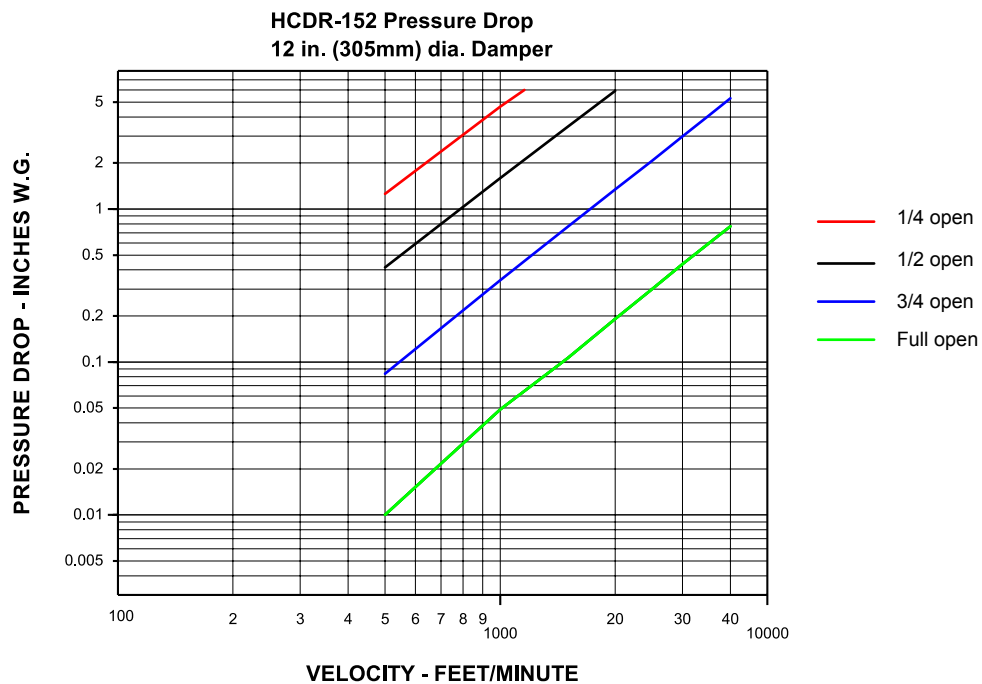

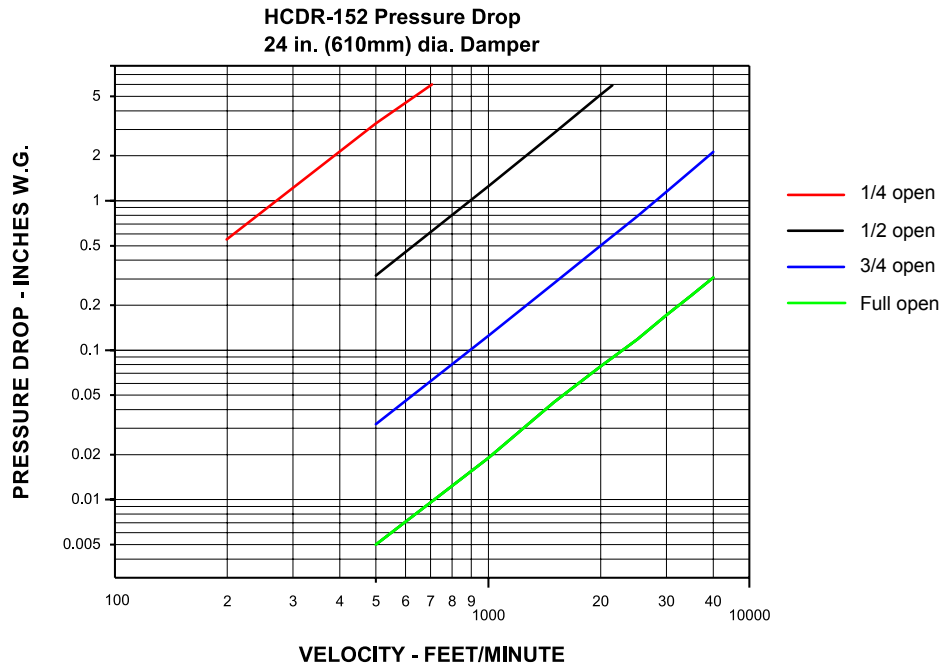

## Leakage Data

Damper leakage (with blades fully closed) varies based on the type of blade stops and low leakage seals applied. Model HCDR-152 is available with no seals (standard) or with EPDM or silicone rubber blade seals. Leakage testing was conducted in accordance with AMCA Standard 500-D and is expressed as cfm/ft<sup>2</sup> of damper face area. All data has been corrected to represent standard air at a density of 0.075 lb/ft<sup>3</sup> (1.2 kg/m<sup>3</sup>).

