

Product Identification

BAPI's "Touch" Pressure Sensor is an accurate, rugged and economical solution for measuring and reporting duct/building static pressure, room-to-room differential pressure or air velocities/volumes. The heart of the unit is a micro-machined silicon pressure sensor with excellent accuracy, repeatability and stability.

The touch interface allows for quick and easy menu driven set up of all parameters including auto zero, pressure ranges, output ranges, W.C. or Pascal operation, and display format of pressure, percent output or "On". You can also use the interface to create custom ranges by adjusting the upper and lower pressure endpoints.

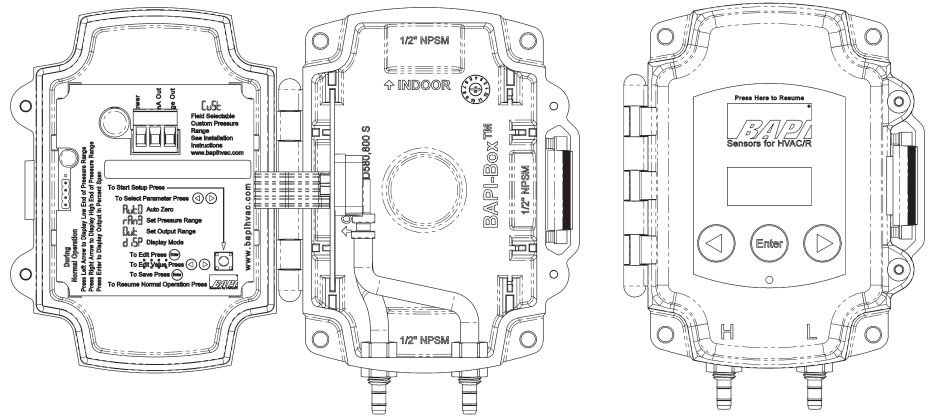

Fig. 1: Zone Pressure Touch (ZPT), Enclosure Open and Closed

Specifications

Power:

7 to 40 VDC (4 to 20 mA Output)
 7 to 40 VDC or 18 to 32 VAC (0 to 5 or 1 to 5 VDC Output)
 13 to 40 VDC or 18 to 32 VAC (0 to 10 or 2 to 10 VDC Output)

Power Consumption:

20 mA max, DC only at 4 to 20 mA Output
 4.9 mA max DC at 0 or 1 to 5 VDC or 0 or 2 to 10 VDC Output
 0.12 VA max AC at 0 or 1 to 5 VDC or 0 or 2 to 10 VDC Output

Load Resistance:

4 to 20 mA Output 850 Ω Maximum @ 24 VDC
 0 to 5 VDC or 0 to 10 VDC output 1KΩ minimum

Customer Editable Parameters:

Auto-Zero, Pressure Range, Output Range, & Display

Accuracy at 72°F: ±0.25% of range

Stability: ±0.25% F.S. per year

Environmental Operation Range: 32 to 140°F (0 to 60°C)

Storage Temperature: -40 to 203°F (-40 to 95°C)

Temperature Error: 0.01% FS/°F (0.02% FS/°C)
 (±5.0" WC @ -4 to 140°F [-20 to 60°C])

Overpressure: Proof 27.68" WC (1 PSI),
 Burst 41.52" WC (1.5 PSI)

Wiring: 2 wires (4 to 20mA Current loop)
 3 wires (AC or DC powered, Voltage out)

LED: Blue power and Auto-Zero indicator

Connector: Removable 3-terminal plug, 12 to 28 AWG

Humidity: 0 to 95% RH, non-condensing

Port Connection: 1 High Pressure & 1 Low Pressure for
 push-on 1/4" tubing (1/8 to 3/16" I.D.)

Enclosure Material: UV-resistant Polycarb., UL94, V-0

Enclosure Rating: IP66, NEMA 4

Mounting: Four external tabs with holes for #10 screws

Ranges: Imperial or metric units available through setup

Setup Buttons: 3-Waterproof capacitive touch through
 cover; Left Arrow, Enter, Right Arrow

Display: 4-Digit, 0.368 Inch (9.4 mm) tall

Agency: CE, RoHS

Table 1: Pressure Ranges

Inches Unit				Pascal Unit			
Range	Pressure	Range	Pressure	Range	Pressure	Range	Pressure
71	0 to 1.00 in W.C.	76	± 1.00 in W.C.	81	0 to 250 Pa	86	± 250 Pa
72	0 to 2.00 in W.C.	77	± 2.00 in W.C.	82	0 to 300 Pa	87	± 300 Pa
73	0 to 2.50 in W.C.	78	± 2.50 in W.C.	83	0 to 500 Pa	88	± 500 Pa
74	0 to 3.00 in W.C.	79	± 3.00 in W.C.	84	0 to 1,000 Pa	87	± 1,000 Pa
75	0 to 5.00 in W.C.	80	± 5.00 in W.C.	85	0 to 1,250 Pa	90	± 1,250 Pa

Specifications subject to change without notice.

Mounting

Attach the unit to its mounting surface with four #10 screws through the holes in the mounting feet. The preferred mounting orientation is with the pressure ports facing down.

Note: Remove Blue Dust Shields from pressure ports before use. Push tubing onto the port nipple. Avoid kinks and holes in the tubing or accuracy will be affected.

Note: BAPI recommends using #10 screws that require 5/32" pilot holes

Note: Do not mount to a vibrating Surface

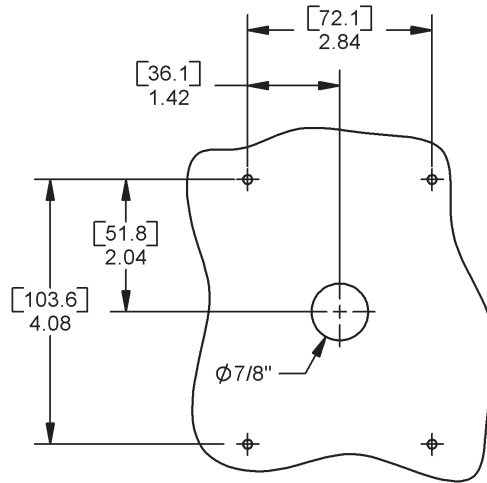

Fig 2: Mounting Hole Pattern

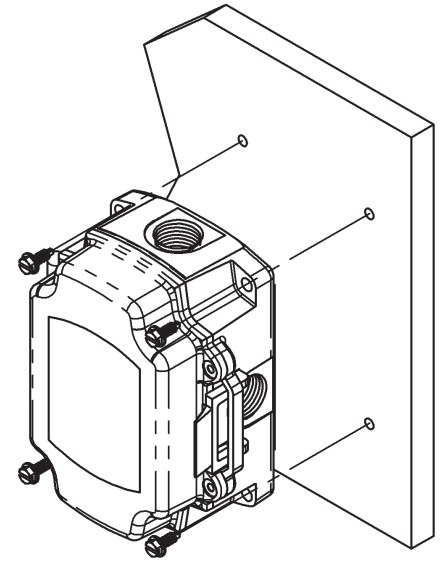

Fig 3: Mounting Screws Location

Wiring Termination

Current Loop Connection

The ZPT unit requires DC voltage for 4 to 20 mA current loop output, which is “two-wire” operation.

Current Loop Output Connection	
Terminal	Function
V+/Power	7 to 40 VDC
GND/4 to 20mA Out	4 to 20 mA Signal Output
Voltage Out	Not used

Voltage Output Connection

The ZPT unit allows AC or DC voltage for voltage output, which is “three-wire” operation.

Voltage Output Connection	
Terminal	Function
V+/Power	7 to 40 VDC or 18 to 32 VAC (for 0 to 5 or 1 to 5 VDC Output) 13 to 40 VDC or 18 to 32 VAC (for 0 to 10 or 2 to 10 VDC Output)
GND/4 to 20mA Out	To controller Ground [GND or Common]
Voltage Out	Voltage Output, Pressure Signal, referenced to GND

Note: Wiring plug removed for clarity. Wiring plug shown in Fig 1.

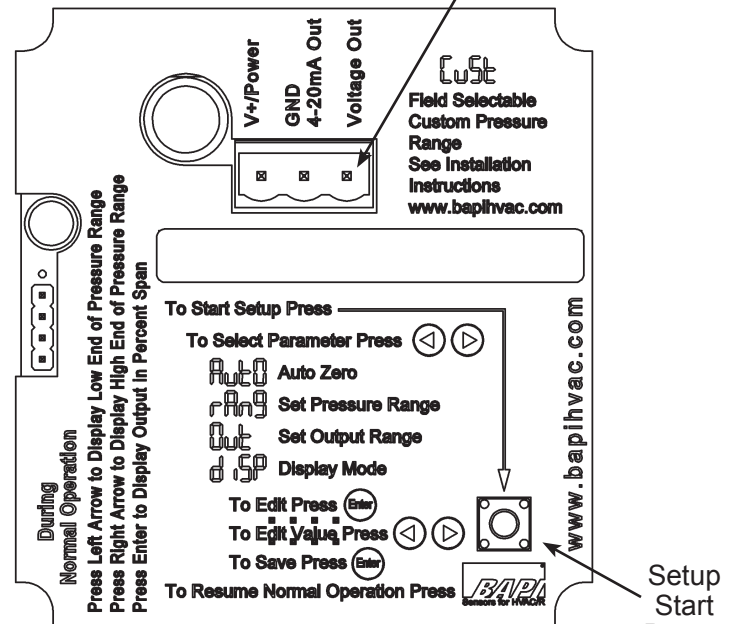

Fig 4: Wiring Terminals Inside Enclosure Cover

NOTE: The connectors use a rising block screw terminal to hold the wires. It is possible for the block to be in a partially up position allowing the wire to be inserted under the block. Be sure that the connector screws are turned fully counterclockwise before inserting the wire. Lightly tug on each wire after tightening to verify proper termination.

Specifications subject to change without notice.



Zone Pressure Touch (ZPT) Sensor - Standard Range

Installation and Operation Instructions

32215_ins_ZPT_SR_NT.pdf

rev. 05/09/2014

Normal Operation

During normal operation, the LCD shows the differential pressure between the high and low pressure ports of the transmitter. The LCD allows enhanced troubleshooting by showing the actual differential pressure over the entire operational pressure range of the sensor regardless of which pressure range is selected. For instance, if the 2.50 inch Water Column range is selected and 3.75 inches Water Column is present, the electrical output of the sensor maxes out. The facility maintenance personnel looking at the sensor output can only tell that the pressure is greater than 2.50 inches Water Column. With the display showing the actual pressure, it is easier for the maintenance personnel to determine what is causing the error.

Additional Features:

- Pressing the left arrow button displays the low end pressure of the currently selected pressure range for 5 seconds.
- Pressing the enter button shows the electrical output in percent span for 5 seconds.
- Pressing the right arrow button displays the high end pressure of the currently selected pressure range for 5 seconds.

Note: If the display is set to OFF (see Parameter Setup below), pressing the enter button shows the current pressure and a second press displays the electrical output in percent of span.

Parameter Setup

ENTERING AND EXITING PARAMETER SETUP MODE

To perform parameter setup (see setup flow chart, Fig 5, on the last page of this document):

- Open the enclosure cover and press the Setup Start Button on the lower right of the circuit board. (See Fig. 4)
- Close the cover, being careful not to touch the buttons or the BAPI logo.
- Press the right or left arrow buttons to select the entry icon of the parameter needing editing.
- Press the Enter button to select the parameter
- Edit the parameter according to the detailed instructions for each parameter below.
- Be sure that you are at the entry icon for each parameter edited to save the edit.
- To resume normal operation, press the BAPI logo.

Note: You may edit more than one parameter per session. All edits will hold through power downs.

AUTO-ZERO

Perform auto-zero after the unit is mounted and powered.

To auto-zero the BAPI ZPT, remove the tubing from the pressure ports (removing the normal pressure source). Make sure that the pressure ports are sheltered from drafts, including the technician's breath. Ideally the two ports should be connected together with a short piece of tubing, making sure that there are no kinks in the tubing.

Entry Icon for Auto-Zero **AUTO**

- Enter the Auto-Zero Mode as described above in the "Entering and Exiting Parameter Setup Mode".
- When the unit is in Auto-Zero Mode, press and release the Enter button. The display will show "OFF."
- Press and release the Right or Left Arrow button until "On" is displayed.
- Press and release the Enter button. The display will show four dashes, "- - - -."
- When the display shows "Auto," auto-zero is complete and stored.
- Either resume normal operation or edit another parameter.

Continued on next page...

Specifications subject to change without notice.



Zone Pressure Touch (ZPT) Sensor - Standard Range

Installation and Operation Instructions

32215_ins_ZPT_SR_NT.pdf

rev. 05/09/2014

Parameter Setup continued...

PRESSURE RANGE SELECTION

Pressure range selection allows a technician to select inches Water Column or Pascals, uni-directional or bi-directional pressure, one of five standard pressure ranges (1.00", 2.00", 2.50", 3.00", 5.00", 250Pa, 300Pa, 500Pa, 1,000Pa, or 1,250Pa) or input a custom range. The endpoints of the custom range must be between -5.00 and 5.00 inches of Water Column or -1,250 and 1,250 Pascals. The custom range endpoints are selected in increments of 0.1 inches of Water Column or 25 Pascals. The custom range "Hi" pressure endpoint may be at a lower pressure than the "LO" pressure endpoint for reverse acting outputs.

Entry Icon

- Enter the Pressure Range Selection Mode as described in the "Entering and Exiting Parameter Setup Mode" on the previous page.
- Press and release the Enter button. The display will show "in" for inches of Water Column or "PA" for Pascals. Using the Left or Right Arrow buttons, select the desired units.
- Press and release the Enter button. The display will show one of the 5 standard ranges or "CuSt" for the custom range. Using the Left or Right Arrow buttons, select the range, then press and release the Enter button.
 - If one of the standard ranges was selected, the display will show "uni" or "-bi." Using the Left or Right Arrow buttons, select uni-directional or bi-directional pressure.
 - Press and release the Enter button. When the display shows "rAng", one of the standard ranges is selected and stored.
 - Either resume normal operation or edit another parameter.
 - If custom range was selected rather than a standard range, the display will show "Hi."
 - Press and release the Enter button. The display will show the current high end of the custom pressure range. Using the Left or Right Arrow buttons, select the high end pressure desired.
 - Press and release the Enter button. The display will show "LO."
 - Press and release the Enter button. The display will show the current low end of the custom pressure range. Using the Left or Right Arrow buttons select the low end pressure desired.
 - Press and release the Enter button. When the display shows "rAng," the custom range is defined and stored.
 - Either resume normal operation or edit another parameter.

OUTPUT RANGE AND OUTPUT DAMPENING SELECTION

Output range selection allows a technician to select one of four voltage outputs (0 to 5 VDC, 0 to 10 VDC, 1 to 5 VDC, or 2 to 10 VDC) or the 4 to 20 mA current output. This area is also used to set the output dampening to fast or slow. Fast dampening has a time constant of 0.5 seconds. Slow dampening has a time constant of 4 seconds.

Entry Icon

- Enter the Output Range Selection Mode as described in the "Entering and Exiting Parameter Setup Mode" on the previous page.
- Press and release the Enter button. The display will show the current output range. Using the Left or Right Arrow buttons, select the output range desired.
- Press and release the Enter button. The display will show the current output dampening. Using the Left or Right Arrow buttons, select "FAST" or "SLO."
- Press and release the Enter button. When the display shows "Out," the output range is selected and stored.
- Either resume normal operation or edit another parameter.

Continued on next page...

Specifications subject to change without notice.



Zone Pressure Touch (ZPT) Sensor - Standard Range

Installation and Operation Instructions

32215_ins_ZPT_SR_NT.pdf

rev. 05/09/2014

Parameter Setup continued...

DISPLAY ON OR OFF

Setting the display to “on” allows the display to show the current pressure reading during normal operation. Setting the display to “OFF” prevents a casual observer from seeing the pressure reading during normal operation. All the observer will see is the word “On,” indicating that the pressure transmitter is functional. A knowledgeable user can display the pressure range endpoints, current pressure reading, and the output percent of span by pressing the arrow or enter buttons as described on page 3 in the Normal Operation “Additional Features” section.

Entry Icon

- Enter the Display On or Off Mode as described in the “Entering and Exiting Parameter Setup Mode” on the page 3.
- Press and release the enter button. The display will show the current display state, “On” or “OFF”. Using the left or right arrow buttons, select the display state needed.
- Press and release the enter button. When the display shows “diSP,” the display mode is set and stored.
- Either resume normal operation or edit another parameter.

Diagnostics

POSSIBLE PROBLEMS:

LED does not light

Output not tracking pressure properly

POSSIBLE SOLUTIONS:

- Check power connections for proper power

- Remove pressure from ports and perform auto-zero procedure

- Check for proper pressure range selection

- Check for proper output range selection

Specifications subject to change without notice.



Zone Pressure Touch (ZPT) Sensor - Standard Range

Installation and Operation Instructions

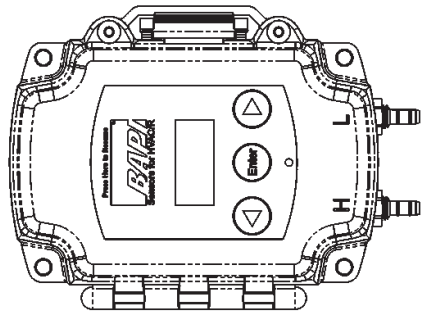
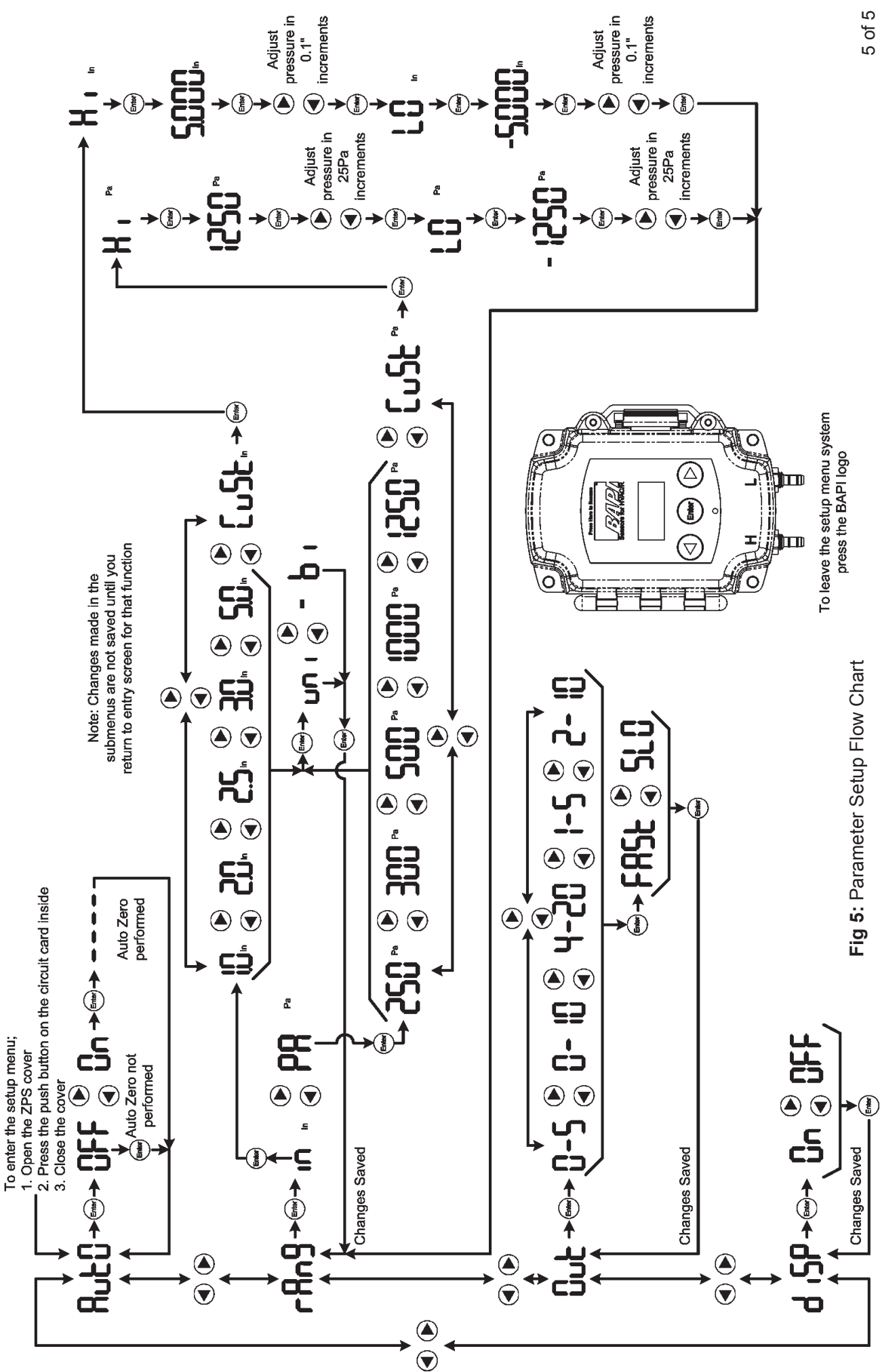

To leave the setup menu system press the BAPI logo

Fig 5: Parameter Setup Flow Chart