



Model SSIMO-311

Combination Fire Smoke Marine Damper for Class A-60 Divisions ABS Approved (PDA)

Application

Model SSIMO-311 is combination fire smoke damper designed for marine application. High strength airfoil blades ensure the lowest resistance to airflow in HVAC systems with velocities to 4,000 fpm (20.3 m/s) and pressures up to 4 in. wg (1 kPa). Model SSIMO-311 may be installed vertically (with blades running horizontal) or horizontally and is rated for airflow and leakage in either direction.

Ratings

- Fire Rating:** A60
- Dynamic Closure Rating:** Actual ratings are size dependent
- Maximum Velocity:** Up to 3,000 fpm (15.2 m/s)
- Maximum Pressure:** 4 in. wg (1kPa)
- Leakage Rating**
 - Leakage Class:** 3 cfm/ft² @ 1 in. wg (35 cmh/m² @ .25 kPa)
6 cfm/ft² @ 4 in. wg (109 cmh/m²@ 1 kPa)
 - Operational Rating:** Actual ratings are size dependent
 - Maximum Velocity:** Up to 4,000 fpm (20.3 m/s), consult factory for higher velocity
 - Maximum Pressure:** 4 in. wg (1kPa)
 - Maximum Temperature:** 212°F (100°C) - depending upon the actuator



Right hand drive is shown. Left hand drive is available upon request. W & H dimension furnished approximately ¼ in. (6mm) undersize.

Model SSIMO-311 meets the requirements for fire dampers, smoke dampers and combination fire smoke dampers established by:

ABS Type Approval Design Assessment (PDA)

Approval Number 16-HS1574429-PDA

Features

- Frames are constructed with reinforced corners. Low profile head and sill are used on sizes less than 17 in. (432mm)
- Blades are a double skin airfoil with full length structural reinforcement

Construction	Standard	Optional
Frame Material	304 stainless steel	-
Frame Material Thickness	16 ga. (1.5mm)	-
Frame Type	5 in. x 1 in. (127mm x 25mm) hat channel	-
Blade Material	304 stainless steel	-
Blade Material Thickness	14 ga. (2mm) equivalent	-
Blade Type	Airfoil	-
Linkage	304SS out of airstream, concealed in jamb	-
Axle Bearings	304SS	-
Axle Material	304SS	-
Blade Seals	Silicone	-
Jamb Seals	304SS	-
Closure Device	RRL	RRL/OCI, PRV, Fusible Link
Closure Temperature	165°F (74°C)	212°F (100°C)
Flanges	Double flange on 304SS sleeve	-
Flange Width	1½ in. (38mm)	2 or 2½ in. (51mm or 64mm)

Size Limitations

W x H	Minimum Size	Maximum Size	
		Single Section	Multiple Section
Inches	8 x 6	32 x 32	64 x 32
mm	203 x 152	813 x 813	1626 x 813

Installation instructions available at www.greenheck.com.

This pressure drop testing was conducted in accordance with AMCA Standard 500-D using the three configurations shown. All data has been corrected to represent standard air at a density of .075 lb/ft³ (1.201 kg/m³).

Actual pressure drop found in any HVAC system is a combination of many factors. This pressure drop information along with an analysis of other system influences should be used to estimate actual pressure losses for a damper installed in a given HVAC system.

AMCA Test Figures

Figure 5.3 Illustrates a fully ducted damper. This configuration has the lowest pressure drop of the three test configurations because entrance and exit losses are minimized by straight duct runs upstream and downstream of the damper.

Figure 5.2 Illustrates a ducted damper exhausting air into an open area. This configuration has a lower pressure drop than Figure 5.5 because entrance losses are minimized by a straight duct run upstream of the damper.

Figure 5.5 Illustrates a plenum mounted damper. This configuration has the highest pressure drop because of extremely high entrance and exit losses due to the sudden changes of area in the system.

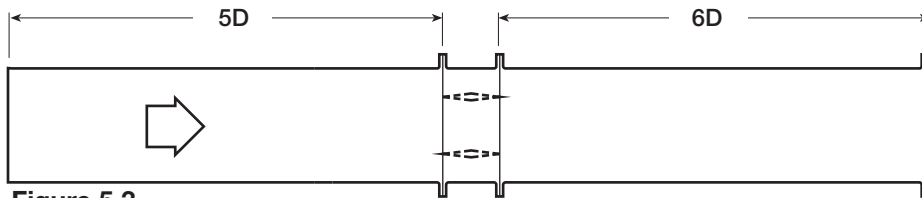

Figure 5.3

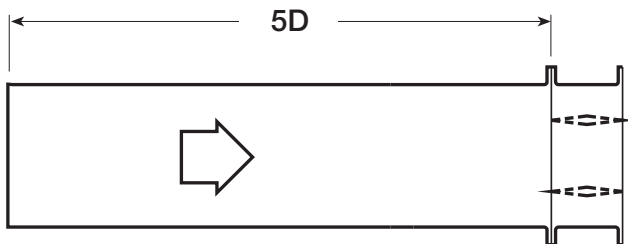

Figure 5.2

$$D = \sqrt{\frac{4(W)(H)}{3.14}}$$

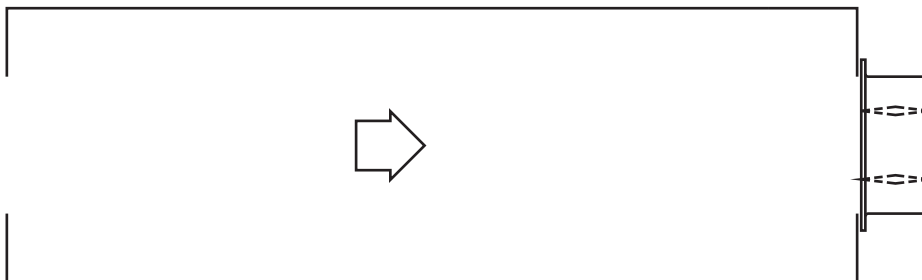
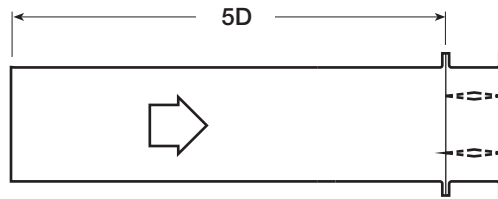

Figure 5.5

AMCA Figure 5.2



12 in. x 12 in. (305mm x 305mm)

Velocity (fpm)	Pressure Drop (in. wg)
500	0.03
1000	0.12
1500	0.26
2000	0.46
2500	0.72
3000	1.04
3500	1.41
4000	1.84

24 in. x 24 in. (610mm x 610mm)

Velocity (fpm)	Pressure Drop (in. wg)
500	0.01
1000	0.06
1500	0.12
2000	0.22
2500	0.34
3000	0.49
3500	0.67
4000	0.87

36 in. x 36 in. (914mm x 914mm)

Velocity (fpm)	Pressure Drop (in. wg)
500	0.01
1000	0.06
1500	0.12
2000	0.22
2500	0.34
3000	0.49
3500	0.67
4000	0.88

12 in. X 48 in. (305mm x 1219mm)

Velocity (fpm)	Pressure Drop (in. wg)
500	0.01
1000	0.05
1500	0.12
2000	0.21
2500	0.33
3000	0.48
3500	0.65
4000	0.85

48 in. x 12 in. (1219mm x 305mm)

Velocity (fpm)	Pressure Drop (in. wg)
500	0.02
1000	0.08
1500	0.18
2000	0.33
2500	0.51
3000	0.74
3500	1.00
4000	1.31

AMCA Figure 5.3

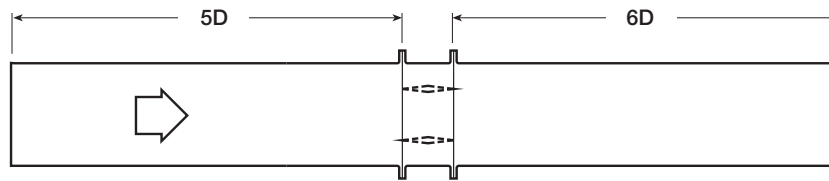

12 in. x 12 in. (305mm x 305mm)

Velocity (fpm)	Pressure Drop (in. wg)
500	0.01
1000	0.06
1500	0.13
2000	0.23
2500	0.37
3000	0.53
3500	0.73
4000	0.95

24 in. x 24 in. (610mm x 610mm)

Velocity (fpm)	Pressure Drop (in. wg)
500	0.01
1000	0.02
1500	0.06
2000	0.10
2500	0.16
3000	0.23
3500	0.32
4000	0.42

36 in. x 36 in. (914mm x 914mm)

Velocity (fpm)	Pressure Drop (in. wg)
500	0.01
1000	0.02
1500	0.05
2000	0.09
2500	0.14
3000	0.21
3500	0.29
4000	0.38

12 in. X 48 in. (305mm x 1219mm)

Velocity (fpm)	Pressure Drop (in. wg)
500	0.01
1000	0.02
1500	0.06
2000	0.10
2500	0.16
3000	0.24
3500	0.33
4000	0.43

48 in. x 12 in. (1219mm x 305mm)

Velocity (fpm)	Pressure Drop (in. wg)
500	0.01
1000	0.04
1500	0.10
2000	0.18
2500	0.29
3000	0.42
3500	0.57
4000	0.74

AMCA Figure 5.5

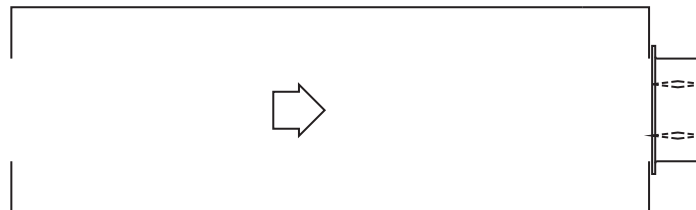

12 in. x 12 in. (305mm x 305mm)

Velocity (fpm)	Pressure Drop (in. wg)
500	0.04
1000	0.18
1500	0.42
2000	0.75
2500	1.17
3000	1.68
3500	2.29
4000	2.99

24 in. x 24 in. (610mm x 610mm)

Velocity (fpm)	Pressure Drop (in. wg)
500	0.03
1000	0.13
1500	0.29
2000	0.52
2500	0.81
3000	1.17
3500	1.60
4000	2.14

36 in. x 36 in. (914mm x 914mm)

Velocity (fpm)	Pressure Drop (in. wg)
500	0.03
1000	0.12
1500	0.27
2000	0.48
2500	0.75
3000	1.08
3500	1.48
4000	1.93

12 in. X 48 in. (305mm x 1219mm)

Velocity (fpm)	Pressure Drop (in. wg)
500	0.03
1000	0.12
1500	0.27
2000	0.49
2500	0.77
3000	1.11
3500	1.51
4000	1.97

48 in. x 12 in. (1219mm x 305mm)

Velocity (fpm)	Pressure Drop (in. wg)
500	0.03
1000	0.14
1500	0.32
2000	0.57
2500	0.89
3000	1.28
3500	1.75
4000	2.29



Greenheck Fan Corporation certifies that the model SSIMO-311 shown herein is licensed to bear the AMCA Seal. The ratings shown are based on tests and procedures performed in accordance with AMCA Publication 511 and comply with the requirements of the AMCA Certified Ratings Programs. The AMCA Certified Ratings Seal applies to air performance ratings only.

Application Data

SSIMO-311

Actuators and Accessories Space Envelopes

Externally mounted actuators always require space outside of the damper sleeve. The "S" dimension illustrates the clearance required for various available actuators.

On dampers less than 18 in. (457mm) high, actuators may also require clearances above and/or below the sleeve. "B" and "T" dimensions are worst case clearance requirements for some dampers less than 18 in. (457mm) high. All damper sizes under 18 in. (457mm) high do not require these worst case clearances. If space availability above or below the damper sleeve is limited, each damper size should be individually evaluated.

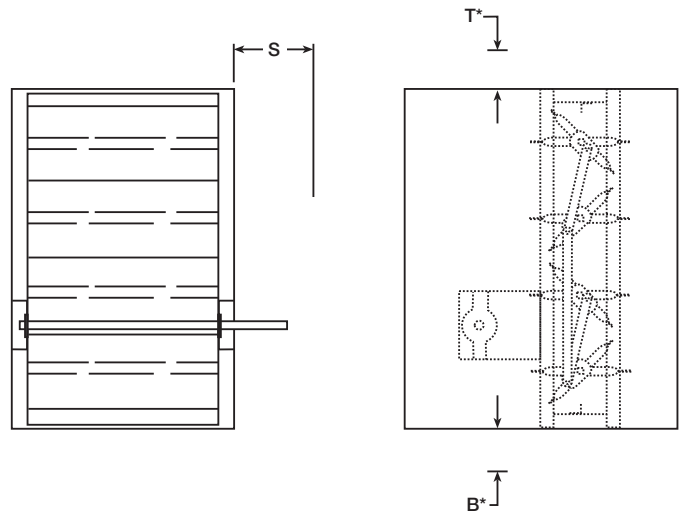

Actuator Type/Model	B*	T*	S	
	With RRL or RRL/OCI	With RRL or RRL/OCI	PiggyBack	
			No	Yes
24 Volt AC				
FSAF24A (-S) Belimo	12¾ in. (324mm)	0	6 in. (152mm)	NA

* For dampers 18 in. (457mm) or more in height these dimensions are 0 in. .

Damper Weights - Weights are approximate. Sizes are in inches (mm).

IMO-311/ SSIMO-311	Actual Size	weight- lb (kg)
	8 x 8 (203x203)	16 (7.3)
	10 x 10 (254x254)	19 (8.6)
	12 x 12 (305x305)	22 (10)
	18 x 18 (457x457)	33 (15)
	20 x 20 (508x508)	36 (16.3)
	24 x 24 (610x610)	44 (20)
	30 x 30 (762x762)	57 (26)
	32 x 32 (813x813)	63 (28.5)
64 x 32 (1626x813)	103 (46.7)	

Damper Sizing Information

Damper larger than the maximum single section size are supplied as a factory assembly of two or more sections of equal size. The following figures show maximum damper section size and assembly configurations for multi-section dampers.

Single Section

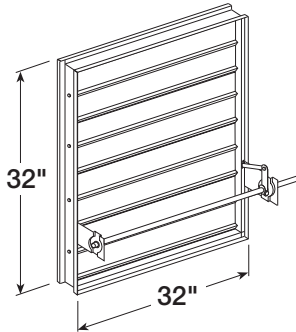

Multi-Section

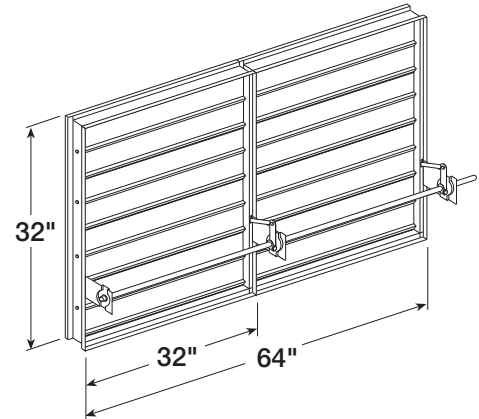

Specifications

Greenheck marine combination fire smoke damper meeting the following specifications shall be furnished and installed where shown on plans and/or as described in schedules.

Dampers shall be tested and rated in accordance with the latest edition of Type A-60 dampers shall consist of: a 16 gauge (1.5mm) 304 stainless steel channel frame with 14 in. (356mm) minimum depth and 1½ in. (38mm) double flanges on 20 ga. (1mm) 304 stainless steel sleeve; ½ in. (13mm) dia. stainless steel axles turning in stainless steel bearings; and external (out of airstream) blade-to-blade linkage.

Damper manufacturer's printed application and performance data including pressure, velocity, and temperature limitations shall be submitted for approval showing damper suitable for pressures up to 4 in. wg (1 kPa), velocities up to 3,000 fpm (15.2 m/s), and temperatures up to 212°F (100°C).

Damper shall be equipped with blade and jamb seals for low leakage performance. Blade seals shall be silicone rubber for 400°F (204°C) maximum temperature. Jamb seals shall be flexible stainless steel.

Basis of design is Greenheck SSIMO-311.

