

Application and Design

The VCD-20V series is a vertical blade general purpose damper for application as an automatic control or manual balancing damper. This model is intended for application in low to medium pressure and velocity systems.



*W&H dimension furnished approximately 1/4 in. (6mm) undersize.

Construction	Standard	Optional
Frame Material	Galvanized steel	304SS
Frame Material Thickness	16 ga. (1.5mm)	12 ga. (2.7mm)*
Frame Type	5 in. x 1 in. (127mm x 25mm) hat channel	Single flange, reversed flange or double flange
Blade Material	Galvanized steel	304SS
Blade Type	3V	-
Blade Action	Opposed	Parallel
Linkage	Plated steel out of airstream, concealed in jamb	316SS
Axle Bearings	Synthetic with thrush washers	316SS with thrush washers
Axle Material	Plated steel	316SS
Paint Finishes	Mill Finish	Baked Enamel, Hi Pro Polyester, Industrial Epoxy

*When 12 ga. frame is selected and the damper height is less than 17 inches, low profile side members are utilized. These low profile frame members will be made from 16 ga. material.

Flange Options

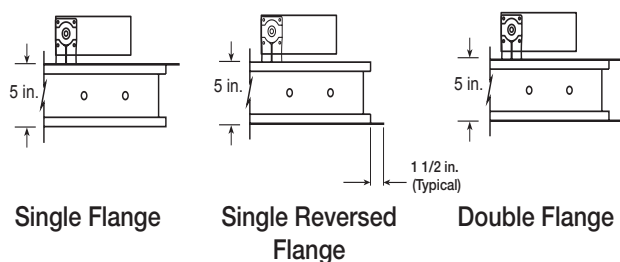

Damper Ratings (See page 4 for specific limitations)

- Pressure:** Up to 5.0 in. wg (1.2 kPa) - pressure differential
- Velocity:** Up to 3000 fpm (15.2 m/s)
- Temperature:** -40°F to 250°F (-40°C to 121°C). Consult factory for higher temperatures.

Features and Options:

- Actuators: electric or manual operators. Actuators (when supplied) are mounted on the top or bottom
- Low profile jambs are used on sizes less than 17 in. (432mm) high.
- Electric actuator and manual quadrant available. Factory supplied actuators are sized for 1500 fpm (7m/s) and fully closed differential pressure of 2 in. wg (.5 kPa). contact factory for actuator sizing on applications exceeding those limits.

Size Limitations

W x H	Minimum Size	Maximum Size	
		Single Section	Multi-Section
Inches	6 x 6	74 x 48	148 x 96
mm	152 x 152	1880 x 1219	3759 x 2438

Blade Operation

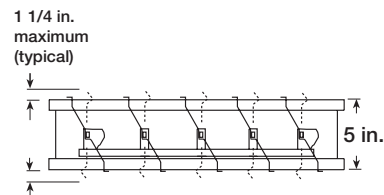

Parallel Blades

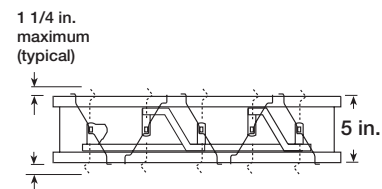

Opposed Blades

This pressure drop testing was conducted in accordance with AMCA Standard 500-D using the three configurations shown. All data has been corrected to represent standard air at a density of .075 lb/ft³(1.2 kg/m³).

Actual pressure drop found in any HVAC system is a combination of many factors. This pressure drop information along with an analysis of other system influences should be used to estimate actual pressure losses for a damper installed in a given HVAC system.

AMCA Test Figures

Figure 5.2 Illustrates a ducted damper exhausting air into an open area. This configuration has a lower pressure drop than Figure 5.5 because entrance losses are minimized by a straight duct run upstream of the damper.

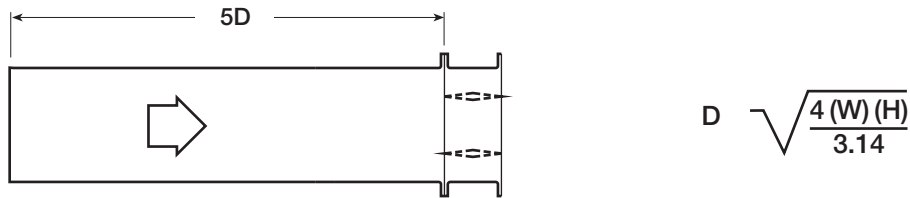

Figure 5.3 Illustrates a fully ducted damper. This configuration has the lowest pressure drop of the three test configurations because entrance and exit losses are minimized by straight duct runs upstream and downstream of the damper.

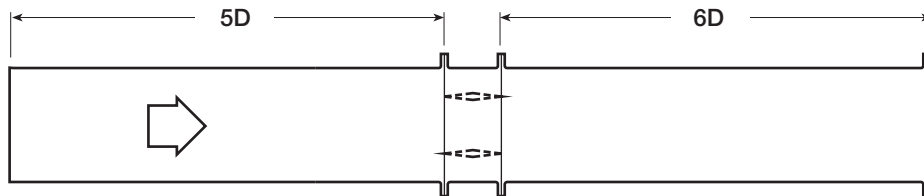
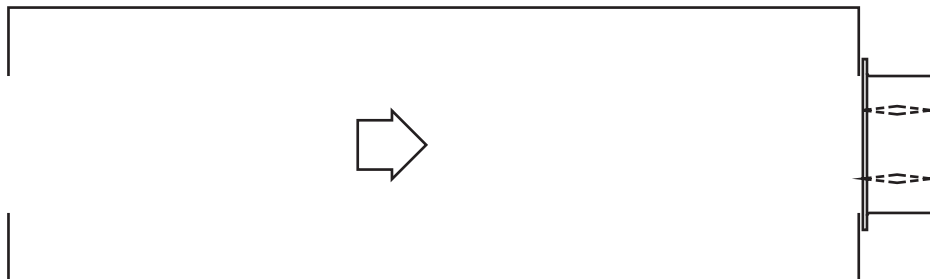

Figure 5.5 Illustrates a plenum mounted damper. This configuration has the highest pressure drop because of extremely high entrance and exit losses due to the sudden changes of area in the system.



Pressure Drop Data

VCD-20V

AMCA 5.2

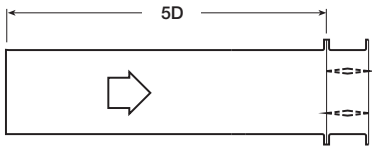

12 in. x 12 in. (305mm x 305mm)

Velocity (fpm)	Pressure Drop (in. wg)
500	0.08
1000	0.31
1500	0.69
2000	1.19
2500	1.84
3000	2.67
3500	3.59
4000	4.64

24 in. x 24 in. (610mm x 610mm)

Velocity (fpm)	Pressure Drop (in. wg)
500	0.01
1000	0.05
1500	0.11
2000	0.19
2500	0.30
3000	0.43
3500	0.58
4000	0.76

36 in. x 36 in. (914mm x 914mm)

Velocity (fpm)	Pressure Drop (in. wg)
500	0.01
1000	0.04
1500	0.09
2000	0.16
2500	0.24
3000	0.35
3500	0.48
4000	0.62

12 in. x 48 in. (305mm x 1219mm)

Velocity (fpm)	Pressure Drop (in. wg)
500	0.01
1000	0.05
1500	0.11
2000	0.20
2500	0.30
3000	0.43
3500	0.59
4000	0.77

48 in. x 12 in. (1219mm x 305mm)

Velocity (fpm)	Pressure Drop (in. wg)
500	0.06
1000	0.23
1500	0.52
2000	0.91
2500	1.43
3000	2.05
3500	2.82
4000	3.69

AMCA 5.3

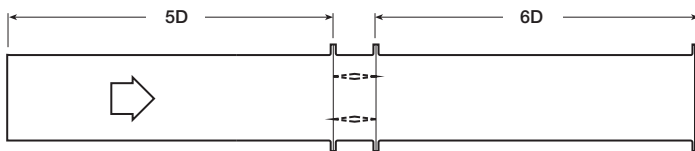

12 in. x 12 in. (305mm x 305mm)

Velocity (fpm)	Pressure Drop (in. wg)
500	0.05
1000	0.20
1500	0.45
2000	0.76
2500	1.19
3000	1.70
3500	2.29
4000	2.97

24 in. x 24 in. (610mm x 610mm)

Velocity (fpm)	Pressure Drop (in. wg)
500	0.01
1000	0.02
1500	0.05
2000	0.10
2500	0.15
3000	0.22
3500	0.30
4000	0.40

36 in. x 36 in. (914mm x 914mm)

Velocity (fpm)	Pressure Drop (in. wg)
500	0.01
1000	0.02
1500	0.04
2000	0.07
2500	0.10
3000	0.15
3500	0.20
4000	0.27

12 in. x 48 in. (305mm x 1219mm)

Velocity (fpm)	Pressure Drop (in. wg)
500	0.01
1000	0.03
1500	0.07
2000	0.12
2500	0.19
3000	0.26
3500	0.36
4000	0.46

48 in. x 12 in. (1219mm x 305mm)

Velocity (fpm)	Pressure Drop (in. wg)
500	0.03
1000	0.13
1500	0.29
2000	0.51
2500	0.81
3000	1.16
3500	1.59
4000	2.09

AMCA 5.5

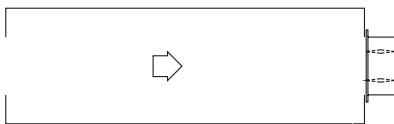

12 in. x 12 in. (305mm x 305mm)

Velocity (fpm)	Pressure Drop (in. wg)
500	0.1
1000	0.40
1500	0.88
2000	1.54
2500	2.41
3000	3.45
3500	4.75
4000	6.09

24 in. x 24 in. (610mm x 610mm)

Velocity (fpm)	Pressure Drop (in. wg)
500	0.03
1000	0.12
1500	0.29
2000	0.52
2500	0.80
3000	1.14
3500	1.60
4000	2.14

36 in. x 36 in. (914mm x 914mm)

Velocity (fpm)	Pressure Drop (in. wg)
500	0.03
1000	0.11
1500	0.26
2000	0.46
2500	0.72
3000	1.04
3500	1.43
4000	1.87

12 in. x 48 in. (305mm x 1219mm)

Velocity (fpm)	Pressure Drop (in. wg)
500	0.03
1000	0.12
1500	0.27
2000	0.49
2500	0.76
3000	1.11
3500	1.53
4000	2.00

48 in. x 12 in. (1219mm x 305mm)

Velocity (fpm)	Pressure Drop (in. wg)
500	0.08
1000	0.29
1500	0.63
2000	1.12
2500	1.76
3000	2.52
3500	3.40
4000	4.52

Space Envelopes

Space Envelopes

On dampers less than 18 in. (457mm) high, actuators may also require clearances above and/or below the damper frame. “B” and “T” dimensions are worst case clearance requirements for some dampers less than 18 in. (457mm) high. All damper sizes under 18 in. (457mm) high do not require these worst case clearances. If space availability above or below the damper is limited, each damper size should be individually evaluated.

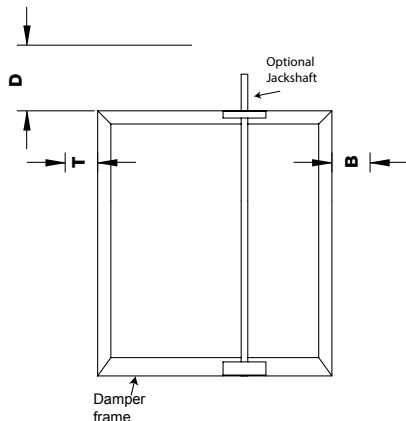

Velocity Limitations

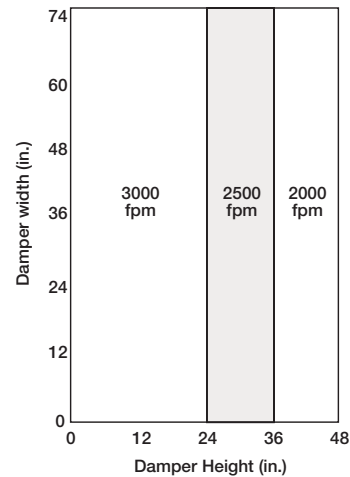

Actuator Type/Model	Width	T	B	D
	Inches (mm)			
AFBUP (-S) and FSNF Series, Belimo MSxx20 Series, Honeywell	≥6 to <10	0	12.75	6
	≥10 to <18	0	2	6
	≥18	0	0	10
FSLF, LF and TFB Series, Belimo	≥6 to <10	0	3.5	6
	≥10	0	0	6
MSxx04 & MSxx09 Series, Honeywell	≥6 to <9	0	4.75	6
	≥9	0	0	6
MS75xx Series, Honeywell	≥6 to <10	0	12.75	6
	≥10 to <18	0	7	6
	≥18	0	0	6

This drawing depicts the worst case clearance requirements for an actuator with a jackshaft.

Internal mount only Actuator model	A	B	C
All except - EFB & EFCX Series	7¼ in (197 mm)	3¾ in (95 mm)	5⅝ in (136.5 mm)
EFB & EFCX Series	8½ in (216 mm)	6 in (152mm)	8½ in (216 mm)

Mounting

- External - includes extension pin (standoff bracket optional)
- External kit - actuator and all mounting hardware
- Internal - blade lever

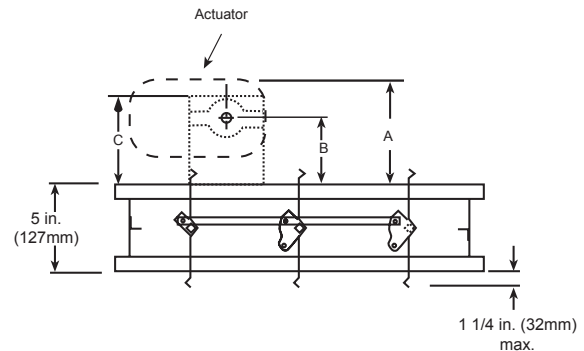

Multi-Section Assembly

Dampers larger than the maximum single section size, will be made up of a multiple of equal size sections. Multiple section dampers can be jackshafted together so that all sections operate together as shown below.

NOTE: Dampers larger than 74 in. x 48 in. (1880mm x 1219mm) are not intended to be structurally self supporting. Additional horizontal bracing is recommended to support the weight of the damper and vertical bracing should be installed as required to hold against system pressure.

Refer to IOM document 463384 for structural support requirements on multi-section assemblies.

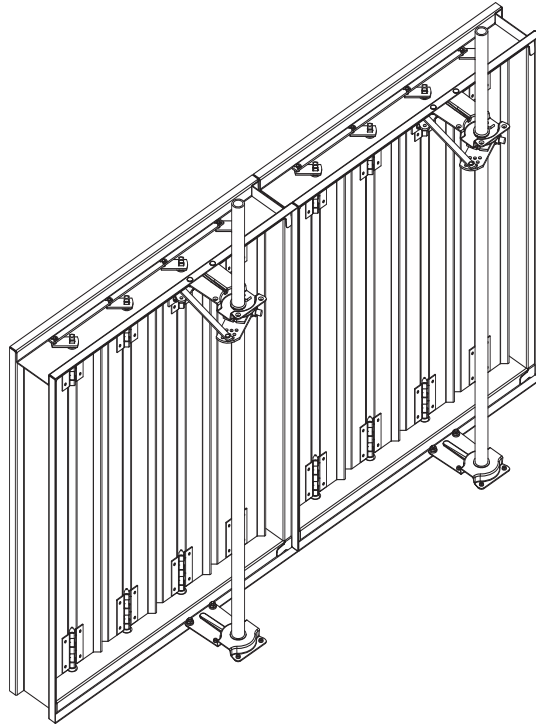

Specifications

Control dampers meeting the following specifications shall be furnished and installed where shown on plans and/or as described in schedules.

Damper blades shall be 16 ga. (1.5mm) galvanized steel 3V type with three longitudinal grooves for reinforcement. Blades shall be symmetrical relative to their axle pivot point, presenting identical resistance to airflow and operation in either direction through the damper (blades that are non-symmetrical relative to their axle pivot point or utilize blade stops larger than 1/2 in. (13mm) are unacceptable). Linkage shall be blade-to-blade concealed in jamb (out of the airstream) to protect linkage and reduce pressure drop and noise.

Damper frame shall be 16 ga. (1.5mm) galvanized steel formed into a structural hat channel shape with reinforced corners to meet 11 ga. (3mm) criteria. Bearings shall be corrosion resistant, permanently lubricated, synthetic (acetal) sleeve type rotating in extruded holes in the damper frame for maximum service. Axles shall be square and positively locked into the damper blade.

Damper manufacturer's printed application and performance data including pressure, velocity and temperature limitations shall be submitted for approval showing damper suitable for pressures to 5 in. wg (1.2 kPa), velocities to 3000 fpm (15.2 m/s) and temperatures to 250°F (121°C).

Basis of design is model VCD-20V.

