

# Isolation & Bypass Dampers and Controls *for Vektor Laboratory Exhaust*



***Greenheck's bypass air dampers and isolation dampers are designed to provide superior airflow control in severe environments.***

System dampers are designed and sized for specified application pressure and flow requirements. Both isolation and and/or bypass air dampers on Vektor systems are available with factory-mounted and wired electric actuators. Each actuator is selected and sized to handle the specific torque requirements of the laboratory application.

## **Greenheck Advantages:**

- Bypass air dampers are custom selected for each system static pressure and flow
- Structurally rigid, airfoil formed steel blades are corrosion-resistant coated steel, formed to operate against high static pressures
- Damper shaft, bearings, and jamb seals are 316 SS
- All non-stainless components have a polyester resin powder coating, electrostatically applied and baked at 400°F. (Standard on isolation dampers, optional on bypass air dampers).
- Damper and drive linkage is factory set and welded to prevent mechanical slippage. Linkage and operators are outside of the hazardous/corrosive exhaust.
- Bypass air dampers use opposed blades for accurate flow control. Isolation dampers maintain plenum containment using tight shut-off parallel blades.
- Industrial isolation and bypass air dampers are manufactured by Greenheck Fan Corporation, Schofield, Wisconsin USA

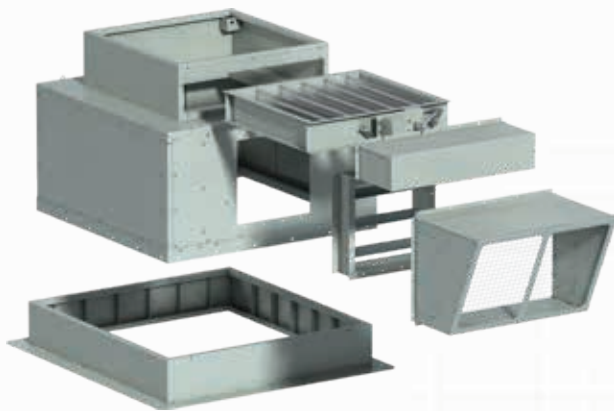

Vektor-M Series Bypass Air Plenum  
and Roof Curb

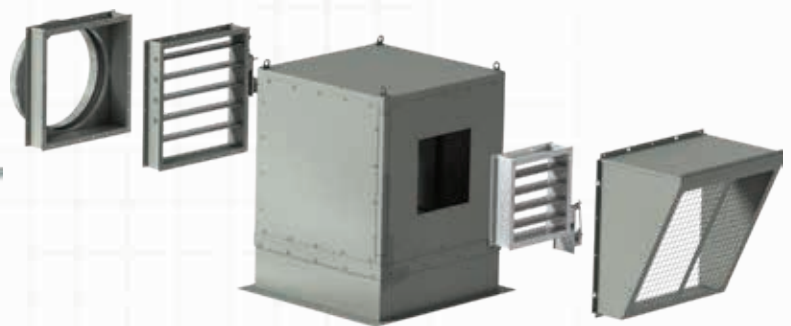

Vektor-C Series Bypass Air Plenum  
and Roof Curb

# Isolation Dampers

Greenheck isolation dampers are designed to prevent air leakage into the system when the fans operate in “stand-by” mode or the system is off. Isolation dampers are two-position actuated as standard (provided with electric actuators as an option), or can be provided as gravity backdraft (please consult the factory).

- 1 Isolation dampers are factory installed and shipped with the bypass air plenum as an assembly; constant volume systems (no bypass air plenum) may have curb mounted isolation dampers
- 2 Standard isolation damper construction includes a polyester resin powder coated and baked, heavy-gauge steel formed casing and airfoil blades. Jamb seals, bearing and blade shafts are stainless steel.
- 3 Isolation dampers can be removed by detaching the cover (Vektor-M) or by removing the compact square-to-round transition (Vektor-C) without accessing the contaminated interior of the bypass air plenum
- 4 Shaft extensions are provided for all actuators. Actuators can be factory-mounted.
- 5 Isolation dampers use parallel airfoil damper blades
- 6 Damper linkage and optional actuator are located outside the exhaust airstream and protected by a weatherproof cover

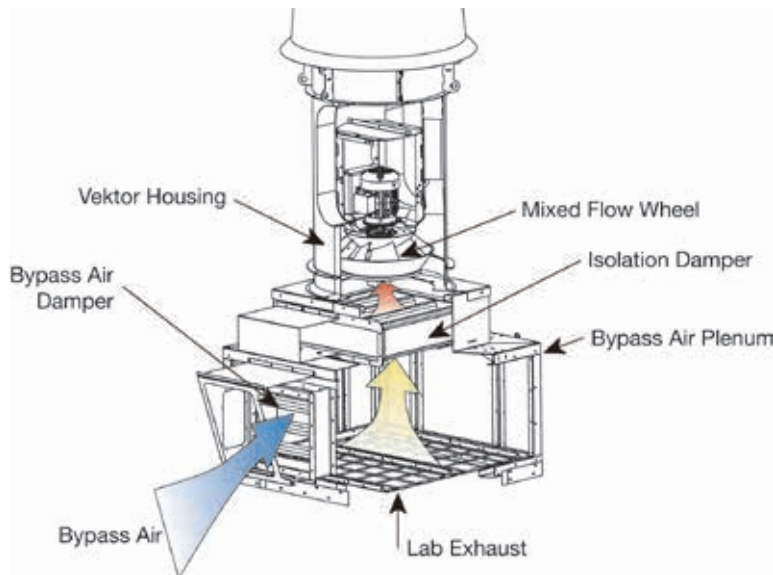
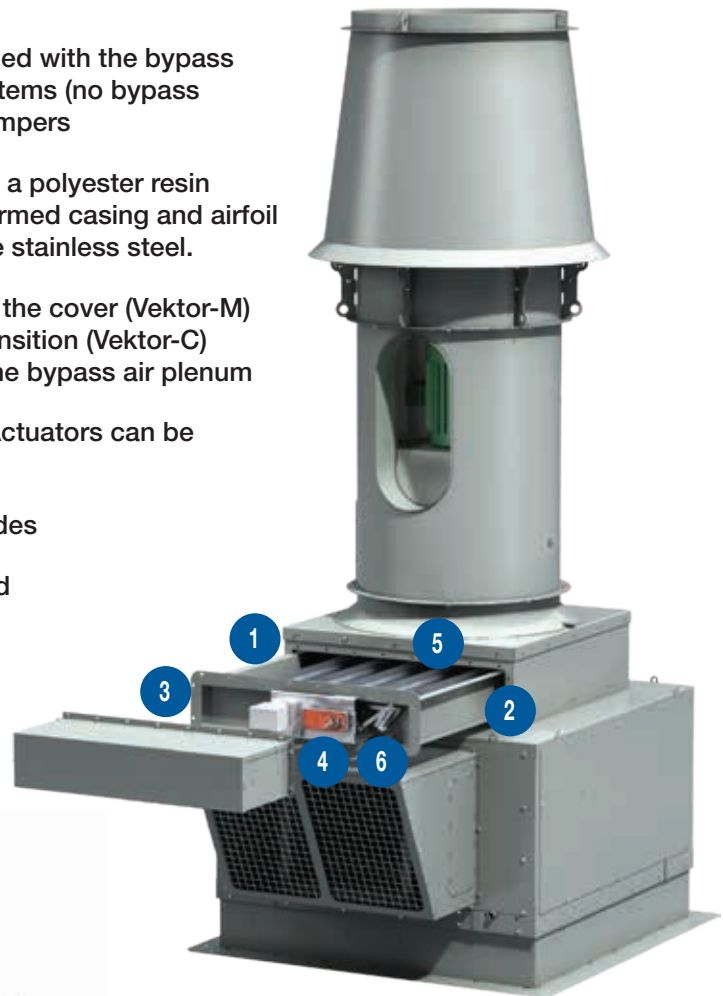

Vektor Isolation Dampers Features and Options	Vektor-M Series	Vektor-C Series
Standard Construction Material (Frame, Blade)	Galv. Steel	Galv. Steel
Stainless Steel Construction Material (Frame, Blade)	Optional	Optional
Hi-Pro Polyester Coating	Yes	Yes
Blade Style	Airfoil	Airfoil
Electric Actuator	Optional	Optional

# Bypass Air Dampers and Weatherhoods

Greenheck's bypass air dampers mix ambient air with exhaust air from the laboratory space. On variable volume lab exhaust systems, bypass air damper modulation allows reduction in lab exhaust flow while maintaining constant fan discharge flow rate, velocity, and plume rise.

- 1 A weatherhood with the stainless steel birdscreen protects the bypass damper, actuator and damper controls from the ambient elements. Damper actuators and controls are mounted outside of the contaminated exhaust allowing servicing without accessing the contaminated plenum interior.
- 2 Bypass dampers utilize opposed blades for flow control and are sized for each unique system application. Construction includes a polyester resin coated and baked, heavy-gauge steel formed casing and airfoil blades. Jamb seals, bearing and blade shafts are stainless steel. Damper blade edge seals are silicone.
- 3 Bypass dampers are available with optional factory-mounted electric modulating or pneumatic actuators.

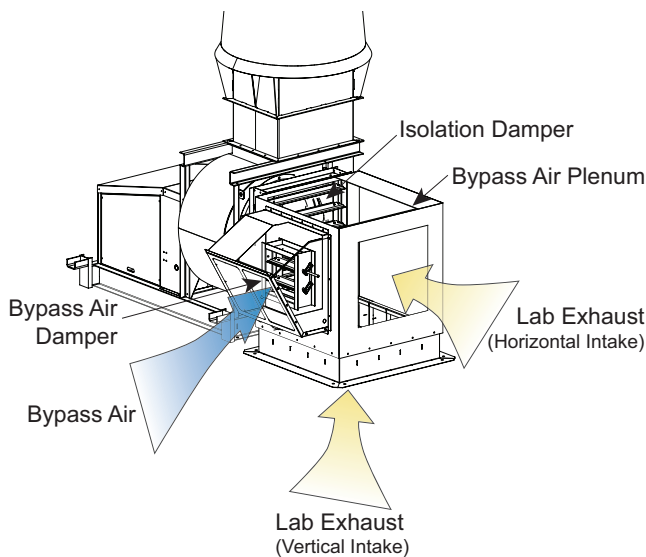
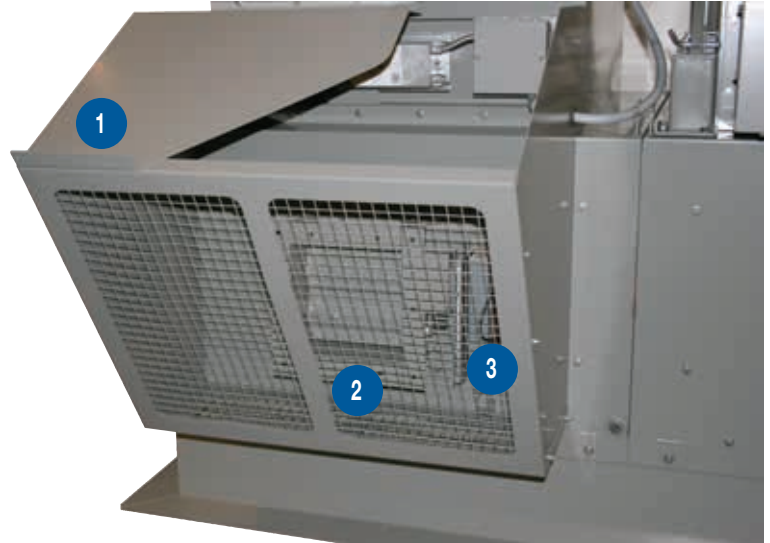

## What Does Bypass Air Do?

As the lab exhaust flow requirement diminishes, the bypass air damper opens, reducing the lab exhaust flow and adding ambient air to the reduced lab exhaust flow. The added bypass air assists in the dispersion of hazardous lab effluent while maintaining constant fan discharge flow, velocity, and plume rise.

When the lab exhaust flow requirement increases, the bypass air damper closes and reduces the amount of added ambient air to the increased lab exhaust.

Bypass air dampers are typically controlled with modulating actuators tied into the laboratory control system.

Vektor Bypass Damper Features and Options	Vektor-M Series	Vektor-C Series
Standard Construction Material (Frame, Blade)	Galv. Steel	Galv. Steel
Stainless Steel Construction Material (Frame, Blade)	Optional	Optional
Hi-Pro Polyester Coating	Optional	Optional
Blade Style	Airfoil	Airfoil
Electric Actuator	Optional	Optional

Vektor lab exhaust isolation and bypass air dampers are available with factory-mounted electric or pneumatic actuators to expedite system installation and to contribute to a safe, operational lab system.



Isolation Damper Actuator and Transformer

### Isolation Damper Actuator Options

- 2-position spring return actuator with end switches
- Electric actuators in 230 VAC, 115 VAC, 24 VAC, or 24 VDC are mounted and wired with transformer
- Single point wiring of the transformer and actuator
- NEMA-1 enclosure (NEMA-4 enclosure optional)



Bypass Damper Actuator

### Bypass Damper Actuator Options

- Modulating operation for bypass airflow control
- Electronic actuators in 230 VAC, 115 VAC, 24 VAC, or 24 VDC (transformers optional)
- NEMA-1 enclosure (NEMA-4 enclosure optional)

## VEKTOR® Family of Lab Exhaust Systems



## Our Commitment

*As a result of our commitment to continuous improvement, Greenheck reserves the right to change specifications without notice.*

Specific Greenheck product warranties are located on [greenheck.com](http://greenheck.com) within the product area tabs and in the Library under Warranties.

P.O. Box 410 • Schofield, WI 54476-0410 • Phone (715) 359-6171 • [greenheck.com](http://greenheck.com)



Prepared to Support  
Green Building Efforts