

Application

Model FSD-312 is a high performance combination fire smoke damper with Class II leakage. High strength airfoil blades ensure the lowest resistance to airflow in HVAC systems with velocities to 4000 fpm (20.3 m/s) and pressures to 8 in. wg (2 kPa). Model FSD-312 may be installed vertically (with blades running horizontal) or horizontally and is rated for airflow and leakage in either direction.

Ratings

UL 555 Fire Resistance Rating

Fire Rating: 1½ hours

Dynamic Closure Rating: Actual ratings are size dependent

Velocity: Up to 4000 fpm (20.3 m/s)

Pressure: Up to 8 in. wg (2 kPa)

UL 555S Leakage Rating

Leakage Class: II

Operational Rating: Actual ratings are size dependent

Velocity: Up to 4000 fpm (20.3 m/s)

Pressure: Up to 8 in. wg (2 kPa)

Temperature: Up to 350°F (177°C) - depending upon the actuator

Construction

	Standard	Optional
Frame Material	Galvanized steel	-
Frame Material Thickness	16 ga. (1.5mm)	-
Frame Type	5 in. x 1 in. (127mm x 25mm) hat channel	-
Blade Material	Galvanized steel	-
Blade Material Thickness	14 ga. (2mm) equivalent	-
Blade Type	Airfoil	-
Blade Action	Opposed	-
Linkage	Plated steel out of airstream, concealed in jamb	316SS
Axle Bearings	316SS	-
Axle Material	Plated steel	316SS
Blade Seals	Silicone	-
Jamb Seals	Stainless Steel	-
Closure Device	RRL	RRL/OCI, TOR, Fusible Link
Closure Temperature	165°F (74°C)	212°F (100°C), 250°F (121°C), 286°F (141°C)*, 350°F (177°C)



Width and Height dimensions furnished approximately ¼ in. (6mm) undersize. Add sleeve thickness for overall sleeved damper dimension. Right hand drive is shown. Left hand drive is available upon request.



See complete marking on product.

UL 555 and UL 555S
Classification R13317

Model FSD-312 meets the requirements for fire dampers, smoke dampers and combination fire smoke dampers established by:

National Fire Protection Association
NFPA Standards 80, 90A, 92, 101 & 105

IBC International Building Codes
CSFM California State Fire Marshal

Fire Damper Listing (#3225-0981:0103)
Leakage (Smoke) Damper Listing (#3230-0981:0104)

W x H	Minimum Size	Maximum Size		
		Single Section	Multiple Section	
			Horizontal	Vertical
Inches	6 x 6	32 x 50	144 x 96	128 x 100
mm	152 x 152	813 x 1270	3658 x 2438	3251 x 2540

*Note: Maximum sizes are dependent on velocities and pressure.

Note:

The frames are constructed with reinforced corners. Low profile head and sill are used on sizes less than 17 in. (432mm) high for lower pressure drop and improved damper performance.

* Only with fusible link

Options and Accessories

- [Breakaway connections](#)
- Clean wrap
- [Greenheck test switches \(GTS\)](#)
- [Grille tabs](#)
- [Momentary switches](#)
- [Retaining angles](#)
- [RRL/OCI](#)
- [Security bars](#)
- Sealed transitions and sleeve
- Smoke detectors
- [TOR](#)
- Transitions: C, O, R

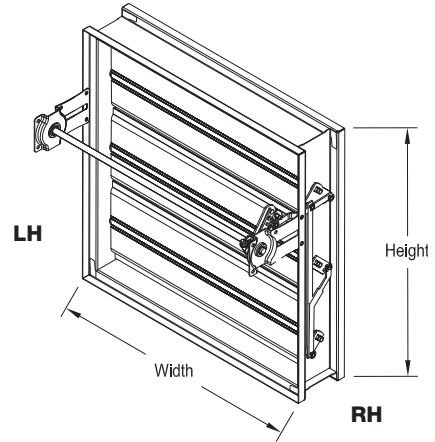

Document Links



[INSTALLATION](#)



[CATALOG](#)



[SELECTION GUIDE](#)



[SPECIFICATIONS](#)



[WARRANTY](#)

Pressure Drop

AMCA Figure 5.2

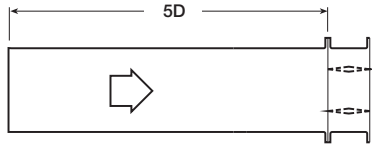

12 in. x 12 in. (305mm x 305mm)

Velocity (fpm)	Pressure Drop (in. wg)
500	0.03
1000	0.11
1500	0.24
2000	0.42
2500	0.66
3000	0.95
3500	1.30
4000	1.70

24 in. x 24 in. (610mm x 610mm)

Velocity (fpm)	Pressure Drop (in. wg)
500	0.01
1000	0.06
1500	0.12
2000	0.22
2500	0.34
3000	0.49
3500	0.67
4000	0.87

36in. x 36 in. (914mm x 914mm)

Velocity (fpm)	Pressure Drop (in. wg)
500	0.01
1000	0.05
1500	0.12
2000	0.21
2500	0.32
3000	0.47
3500	0.63
4000	0.83

12in. X 48 in. (305mm x 1219mm)

Velocity (fpm)	Pressure Drop (in. wg)
500	0.01
1000	0.05
1500	0.12
2000	0.21
2500	0.33
3000	0.48
3500	0.65
4000	0.85

48 in. x 12 in. (1219mm x 305mm)

Velocity (fpm)	Pressure Drop (in. wg)
500	0.02
1000	0.08
1500	0.18
2000	0.33
2500	0.51
3000	0.74
3500	1.00
4000	1.31

AMCA Figure 5.3

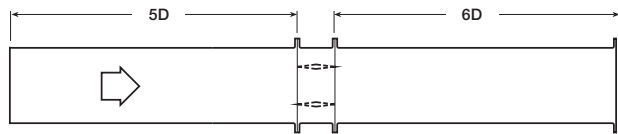

12 in. x 12 in. (305mm x 305mm)

Velocity (fpm)	Pressure Drop (in. wg)
500	0.01
1000	0.06
1500	0.13
2000	0.23
2500	0.37
3000	0.53
3500	0.73
4000	0.95

24 in. x 24 in. (610mm x 610mm)

Velocity (fpm)	Pressure Drop (in. wg)
500	0.01
1000	0.02
1500	0.06
2000	0.10
2500	0.16
3000	0.23
3500	0.32
4000	0.42

36in. x 36 in. (914mm x 914mm)

Velocity (fpm)	Pressure Drop (in. wg)
500	0.01
1000	0.02
1500	0.05
2000	0.09
2500	0.14
3000	0.21
3500	0.29
4000	0.38

12in. X 48 in. (305mm x 1219mm)

Velocity (fpm)	Pressure Drop (in. wg)
500	0.01
1000	0.03
1500	0.06
2000	0.11
2500	0.18
3000	0.25
3500	0.34
4000	0.45

48 in. x 12 in. (1219mm x 305mm)

Velocity (fpm)	Pressure Drop (in. wg)
500	0.01
1000	0.04
1500	0.10
2000	0.18
2500	0.29
3000	0.42
3500	0.57
4000	0.74

AMCA Figure 5.5

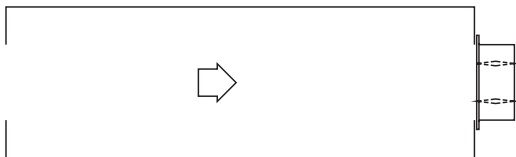

12 in. x 12 in. (305mm x 305mm)

Velocity (fpm)	Pressure Drop (in. wg)
500	0.04
1000	0.18
1500	0.42
2000	0.75
2500	1.17
3000	1.68
3500	2.29
4000	2.09

24 in. x 24 in. (610mm x 610mm)

Velocity (fpm)	Pressure Drop (in. wg)
500	0.03
1000	0.13
1500	0.29
2000	0.52
2500	0.81
3000	1.17
3500	1.60
4000	2.14

36in. x 36 in. (914mm x 914mm)

Velocity (fpm)	Pressure Drop (in. wg)
500	0.03
1000	0.12
1500	0.27
2000	0.48
2500	0.75
3000	1.08
3500	1.48
4000	1.93

12in. X 48 in. (305mm x 1219mm)

Velocity (fpm)	Pressure Drop (in. wg)
500	0.03
1000	0.12
1500	0.27
2000	0.49
2500	0.77
3000	1.11
3500	1.51
4000	1.97

48 in. x 12 in. (1219mm x 305mm)

Velocity (fpm)	Pressure Drop (in. wg)
500	0.03
1000	0.14
1500	0.32
2000	0.57
2500	0.89
3000	1.28
3500	1.75
4000	2.29



Greenheck Fan Corporation certifies that the model FSD-312 shown herein is licensed to bear the AMCA Seal. The ratings shown are based on tests and procedures performed in accordance with AMCA Publication 511 and comply with the requirements of the AMCA Certified Ratings Programs. The AMCA Certified Ratings Seal applies to air performance ratings only.

Space Envelopes

Externally mounted actuators always require space outside of the damper sleeve. The “S” dimension illustrates the clearance required for various available actuators.

Worst case space envelopes shown below. Exact dimensions may vary based on specific damper configuration. Consult factory for specific space envelope if necessary.

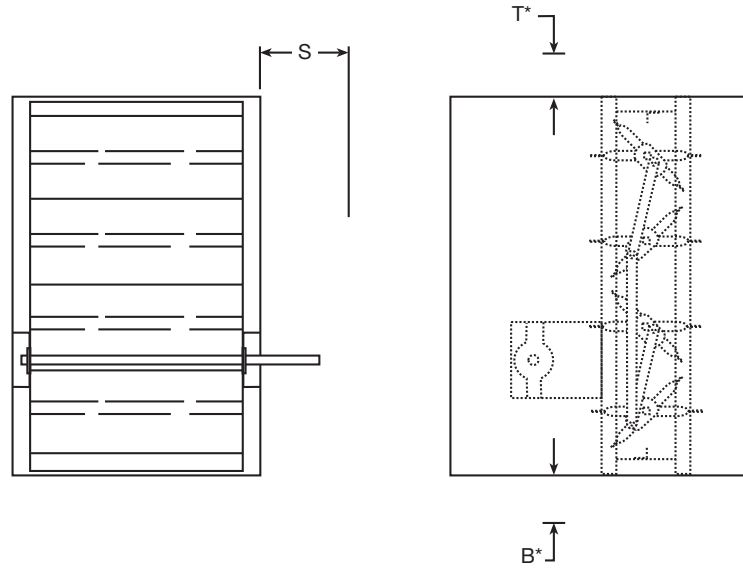

Actuator Type/Model	B*	T*	S	
	With RRL, RRL/OCI, or TOR	With RRL, RRL/OCI, or TOR	Piggyback	
			No	Yes
Belimo				
FSAFB24-SR (-S)	1½ in (38mm)	9¼ in. (235mm)	6 in. (152mm)	9 in. (229mm)
FSLF series	8 in. (203mm)	1½ in (38mm)	6½ in. (165mm)	NA
FSNF series	1½ in (38mm)	9¼ in. (235mm)	6 in. (152mm)	9 in. (229mm)
FSTF Series	8 in. (203mm)	1½ in (38mm)	6½ in. (165mm)	NA
Siemens				
GJD Series	7 in. (178mm)	1½ in (38mm)	6½ in. (165mm)	NA
GRD Series	1½ in (38mm)	7½ in (191mm)	6½ in. (165mm)	NA
GXVD Series	1½ in (38mm)	9¼ in. (235mm)	6 in. (152mm)	9 in. (229mm)
Honeywell				
MS4103, MS8103 Series	8¾ in. (222mm)	1½ in (38mm)	6½ in. (165mm)	NA
MS4104, MS4604, MS8104 Series	1½ in (38mm)	8½ in (216mm)	6½ in. (165mm)	NA
MS4109, MS4609, MS8109 Series	1½ in (38mm)	8½ in (216mm)	6½ in. (165mm)	NA
MS4120, MS4620, MS8120 Series	1½ in (38mm)	9½ in. (241mm)	6 in. (152mm)	9 in. (229mm)

* For dampers 18 in. (457mm) or more in height these dimensions are 0 in.

Contained Actuator Option

Dampers can be ordered with a “contained actuator option”. This option will result in the actuator being oriented such that it extends no more than 1½ inches above or below the sleeve. Note that some damper configurations that are 11 inches high or less will have the RRL, RRL/OCI, or TOR mounted on the side opposite the actuator when the contained actuator option is selected.

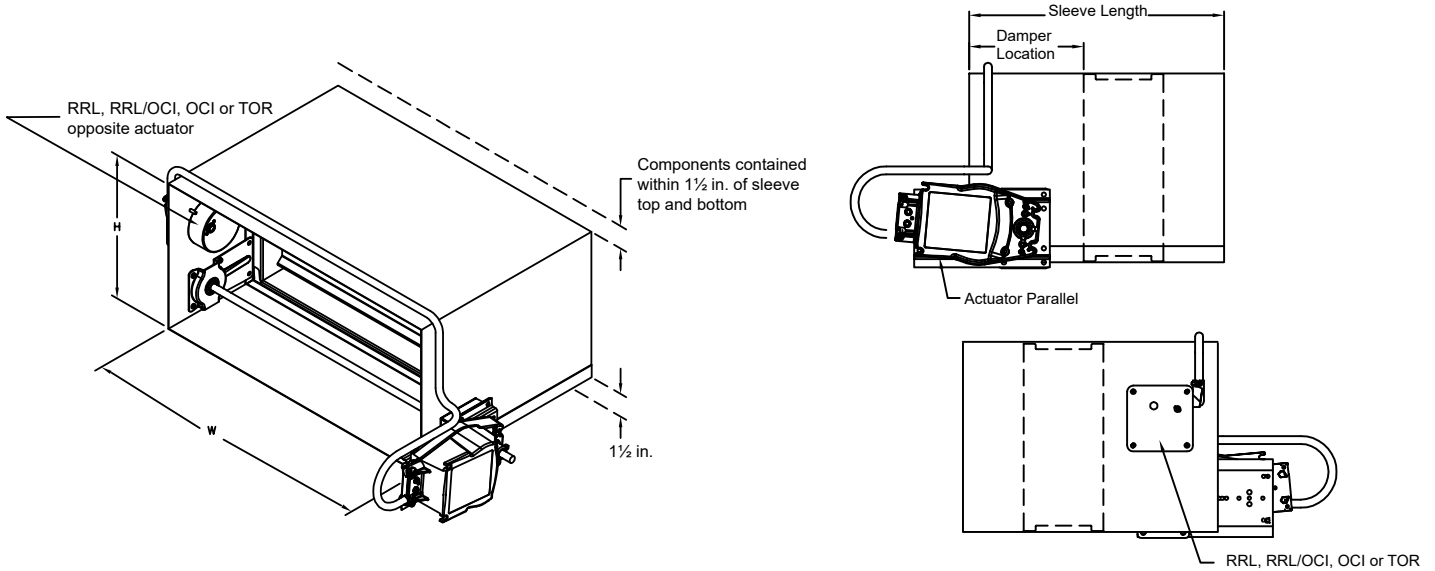

Sleeve and Sideplate Dimensional Data

The drawings below and corresponding table show the position of the FSD-312 damper when mounted in a factory sleeve (“A” dimension). The standard mounting locations provide enough space for the mounting of actuators, controls and allow space for installation of retaining angles and duct connections. The following options may affect the range of available mounting locations: smoke detector, NEMA 7 enclosure, transitions, security bars, grille tabs.

The standard location of a damper mounted in a factory sleeve (“A” dimension) is shown below. The damper can be positioned at other locations within a range of 6 in. (152mm) to 16 in. (406mm) for the “A” dimension.

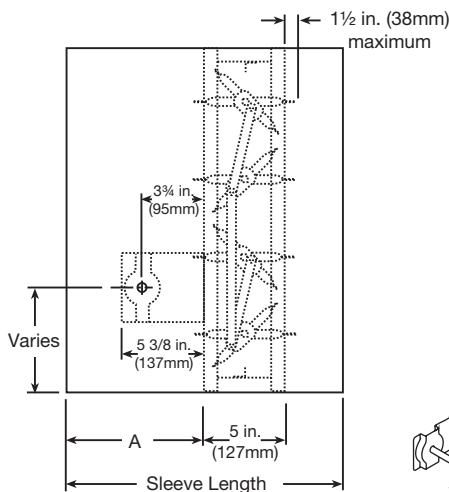

in. (mm)	With Sleeve		Sideplate Damper Location “A”
	Minimum Damper Location “A”	Maximum Damper Location “A”	
Compact configuration*	7 3/16 in. (183)	16 (406)	-
Standard (non-compact) Height < 12 in. (305) RRL, RRL/OCI, or TOR	12 (305)	16 (406)	12 (305)
Standard (non-compact) Height ≥ 12 in. (305) RRL, RRL/OCI, or TOR	7 3/16 in. (183)	16 (406)	12 (305)

* Contact factory for more information.

NOTE: Entire damper frame is not required to be installed within the wall. The damper blades, when closed should be contained within the wall.

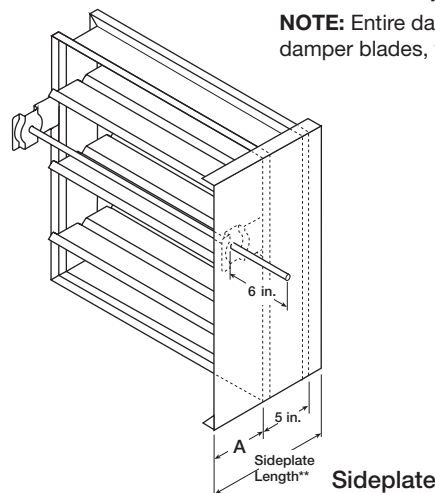

Transitioned Damper Dimensions

When a combination fire smoke damper is being used in conjunction with round or oval ductwork, the FSD-312 can be supplied in a factory sleeve with round or oval transitions on both ends of the sleeve. Dampers should be ordered to the duct dimensions. Drawings below show overall damper size.

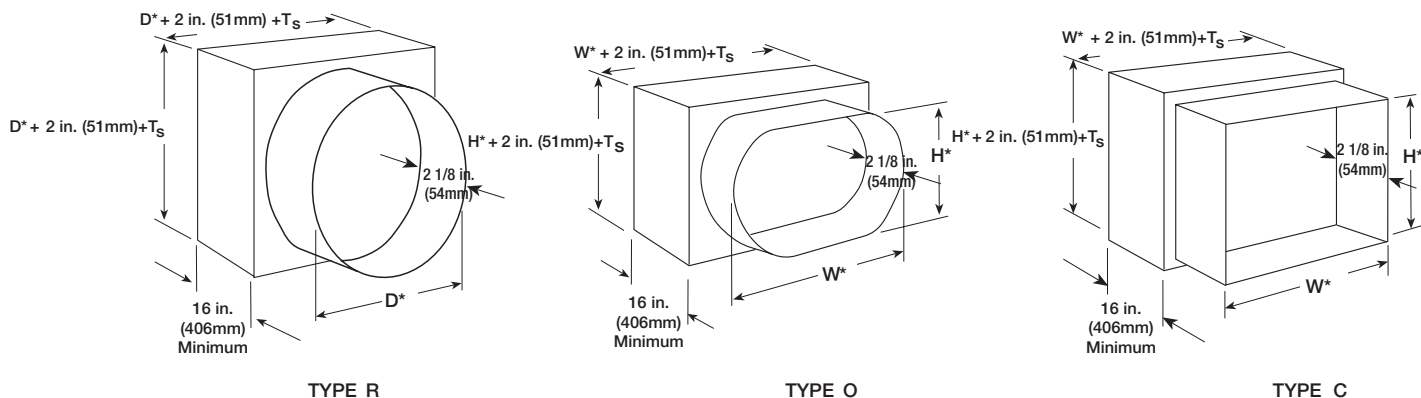

*These dimensions are furnished approximately 1/4 in. (6mm) undersize, except round and oval dimensions which are approximately 1/8 in. (3mm) undersize.
 Ts = (2)(Sleeve Thickness)

Multiple Sections Damper

Dampers larger than maximum single section size are supplied as a factory assembly of two or more sections of equal size. The following figures show maximum damper section size and assembly configurations for multi-section dampers.

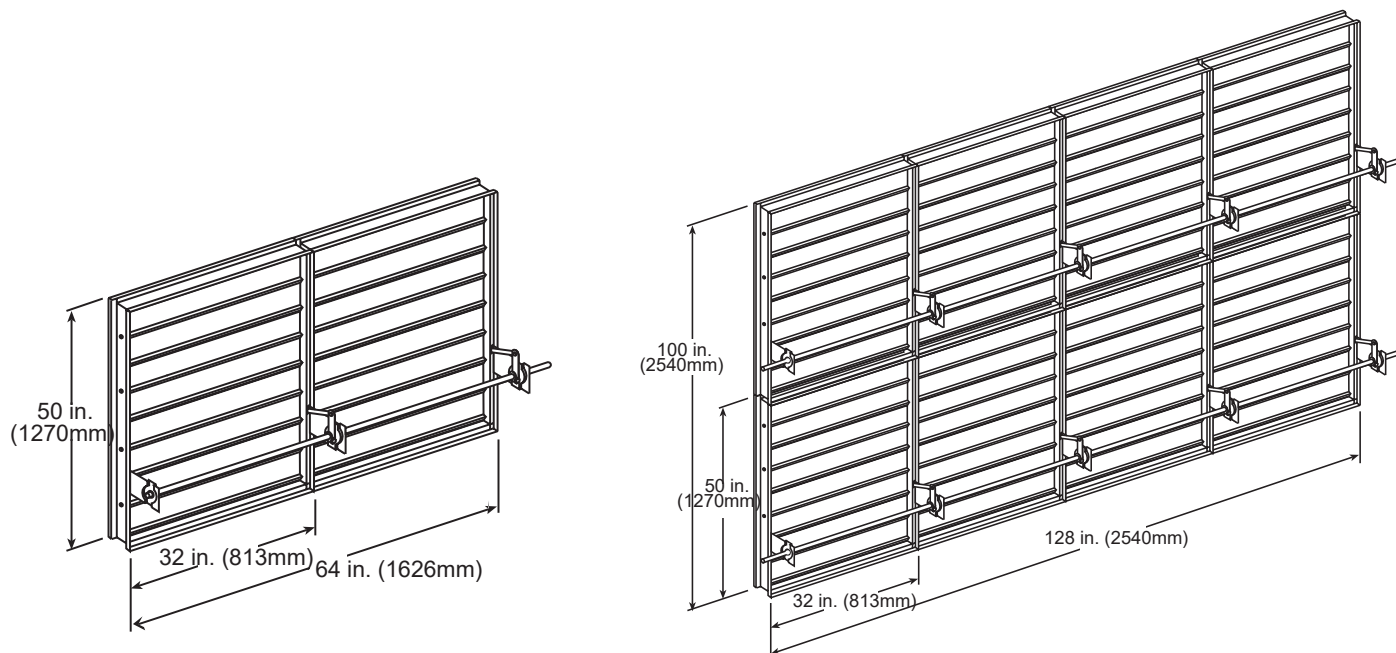

Two Sections

Four sections wide
Two sections high