

Installation, Operation and Maintenance Manual

Please read and save these instructions for future reference. Read carefully before attempting to assemble, install, operate or maintain the product described. Protect yourself and others by observing all safety information. Failure to comply with these instructions will result in voiding of the product warranty and may result in personal injury and/or property damage.

PRG VERSION: V1.00

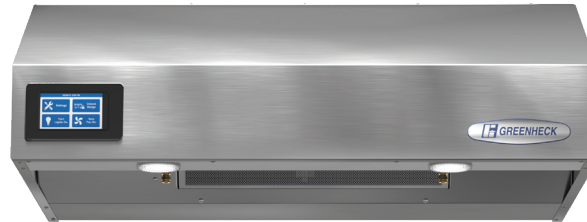

Listed to UL Subject 300A

General Safety Information

Personnel should have a clear understanding of these instructions and all applicable, current local and national building and fire codes before installing this product.

NOTE

All service and maintenance on the fire suppression system should be conducted by an authorized fire equipment distributor. Do not tamper with fire suppression components if not instructed to do so.

WARNING

To reduce the risk of fire, electric shock, or injury to persons, observe the following:

- Use this product only in the manner intended by the manufacturer (to cover domestic ranges used for domestic purposes).
- When cutting or drilling into wall or ceiling, do not damage electrical wiring or other hidden utilities.
- Ducted exhaust fans must always be vented to the outdoors.
- Use only rigid, metal ductwork
- This unit must be properly grounded.

To reduce the risk of range top grease fire:

- Never leave the range unattended at high settings. Boil-overs cause smoking and greasy spillovers that may ignite.
- Dense smoke from frying pans indicates cooking oil is near auto ignition – turn the burner down or off.
- Always turn the hood fan ON when part of the cooking surface is on
- Always make sure the hood grease filter is installed before cooking.
- Clean hood grease filter frequently. Do not allow grease to accumulate on filter.
- Always use proper pan size. Use cookware appropriate for the size of the surface element.
- Keep cooking areas clean and clear of combustible materials.

To reduce the risk of injury to persons in the event of a range top grease fire, observe the following:*

- **SMOTHER FLAMES** with a close-fitting lid, cookie sheet, or metal tray, then turn off the burner. **BE CAREFUL TO PREVENT BURNS.** If the flames do not go out immediately, **EVACUATE AND CALL THE FIRE DEPARTMENT.**
- **NEVER PICK UP A FLAMING PAN.** You may be burned.
- **DO NOT USE WATER,** including wet dishcloths or towels - violent steam explosion will result.

*Based on "Kitchen Fire Safety Tips" published by NFPA.

AVERTISSEMENT

Pour réduire le risque d'incendie, de choc électrique ou de blessure corporelle, respecter ce qui suit :

- Utiliser uniquement ce produit de la façon prévue par le fabricant (pour couvrir les cuisinières domestiques utilisées à la maison).
- Lors de la découpe ou du perçage de murs ou plafonds, ne pas endommager les câbles électriques et autres conduites masquées.
- Les caissons d'extraction à gaine d'évacuation doivent toujours être évacués vers l'extérieur.
- Utiliser uniquement un réseau de gaine rigide, en métal.
- Cet appareil doit être bien raccordé à la terre.

Pour réduire le risque d'incendie de graisse sur le dessus de la cuisinière :

- Ne jamais laisser la cuisinière sans surveillance à des réglages élevés. Les débordements causent de la fumée et des débordements de graisse qui peuvent s'enflammer.
- Une fumée dense provenant de poêles à frire indiquent que l'huile à friture s'approche de son point d'inflammation spontanée. Régler le brûleur plus bas ou l'éteindre.
- Toujours activer le ventilateur de la hotte lorsqu'une partie de la surface de cuisson chauffe.
- Toujours s'assurer que le filtre de graisse de la hotte est installé avant la cuisson.
- Nettoyer fréquemment la graisse du filtre de la hotte. Ne pas laisser s'accumuler la graisse sur le filtre.
- Toujours utiliser la taille appropriée de poêle à frire. Utiliser une batterie de cuisine proportionnelle à la surface de l'élément.
- Garder propre l'aire de cuisson et dégagée de toute matière combustible.

Observer les points suivants pour réduire le risque de blessures aux personnes advenant un incendie de graisse sur le dessus de la cuisinière :*

- **ÉTOUFFER LES FLAMMES** à l'aide d'un couvercle ajusté, d'une plaque à biscuits ou d'un plateau en métal, puis fermer le brûleur. **S'ASSURER D'ÉVITER DES BRÛLURES.** Si les flammes ne s'éteignent pas immédiatement, **ÉVACUER LES LIEUX ET APPELER LE SERVICE D'INCENDIE.**
- **NE JAMAIS SAISIR UNE POËLE EN FLAMME.** Vous pourriez vous brûler.
- **NE PAS UTILISER D'EAU,** ni de linges à vaisselle ni de serviettes mouillées car il pourrait se produire une violente explosion de vapeur.

*Basé sur les « Kitchen Fire Safety Tips » (Conseils de sécurité sur les incendies de cuisine) publiés par la NFPA

Receiving

Product should arrive in a large carton. Upon receiving the product, check to ensure all items are accounted for by referencing the delivery receipt or packing list. Inspect each crate or carton for shipping damage before accepting delivery. Alert the carrier of any damage detected. The customer will make notation of damage (or shortage of items) on the delivery receipt and all copies of the bill of lading which is countersigned by the delivering carrier. If damaged, immediately contact your Greenheck Representative. Any physical damage to the unit after acceptance is not the responsibility of the manufacturer.

Unpacking

Verify that all required parts and the correct quantity of each item have been received. If any items are missing, report shortages to your local representative to arrange for obtaining missing parts. Confirmation of shipment(s) must be limited to only items on the bill of lading.

Parts Checklist

- Hood with factory-installed Fire Suppression System
 - Finished Top (optional)
 - Ceiling Enclosures (optional)
- LED Lights (Qty. 2)
- Wall Mounting Bracket with J-Box
 - Hood latch catches (Qty. 2)
- External Inline Fan (optional)
 - One (1) 50 ft. Plug and Play Cable
- Gas Disconnect (optional)
 - 3/4 inch Gas Valve (plugs into gas shut off assembly box)
 - Gas Shut Off Assembly Box with 115VAC Range Receptacle
 - Two (2) 10 ft. Plug and Play Cables
- Electrical Disconnect (optional)
 - Electric Shut Off Assembly Box with 250VAC Range Receptacle
 - Two (2) 10 ft. Plug and Play Cables
- Shipped Loose User Interface (optional)
 - Recessed-Mount J Box
 - One (1) 10 ft. Plug and Play Cable
- Manual Pull Station (optional)
 - One (1) 30 ft. Plug and Play Cable
- Horn Strobe (optional)
 - One (1) 8 ft. Cable
- Wall Cap (optional)
- K-Class Portable Fire Extinguisher (optional)
- Fire Test Cylinder (optional)

- Additional: Spare Fuse, Qty. 1 6A Fuse

Handling

Handle hood and accessories in such a manner as to keep from scratching or chipping the coating. Damaged finish may reduce ability of unit to resist corrosion.

Storage and Install Location Requirements

Units are protected against damage during shipment. If the unit cannot be installed and operated immediately, precautions need to be taken to prevent deterioration of the unit during storage. The user assumes responsibility of the unit and accessories while in storage. The manufacturer will not be responsible for damage during storage. The suggestions are provided solely as a convenience to the user.

The ideal environment for the storage of units and accessories is indoors, above grade, in a low humidity atmosphere which is sealed to prevent the entry of blowing dust, rain, or snow. Temperatures should be evenly maintained between 32°F (0°C) and 120°F (49°C). All accessories must be stored indoors in a clean, dry location.

WARNING

The fire suppression system needs to be stored and installed in locations where the temperature will not fall below 32°F (0°C) and not exceed 120°F (49°C) for proper operation.

AVERTISSEMENT

Le système extincteur d'incendie doit être entreposé et installé dans des endroits où la température ne descend pas sous 0°C (32°F) et ne dépasse pas 49°C (120°F) pour un bon fonctionnement.

Table of Contents

- Receiving, Unpacking, Parts Checklist, Handling and Storage 2
- Model Number Code 3
- Hood Exploded View 3
- Ventilation and Fan Type Configurations 4
- Installation
- General Information and Hood Weights 7
- Dimensional Data and Mounting Bracket 8
- Ductwork 9
- Hood 9
- External Fan 10
- Range Disconnect
- Gas / Electric 10
- Accessories
- Remote Mounted User Interface 11
- Finished Top 11
- Ceiling Enclosures 11
- Wall Cap 11
- Manual Pull Station 12
- Horn Strobe 12
- Fire Extinguisher 12
- Electrical Connections
- Hood Power 13
- Fan Power - Integral or External Fan 13
- Range Disconnect
- Gas / Electric 13-14
- Accessories
- Remote Mounted User Interface 15
- Manual Pull Station 15
- Horn Strobe 15
- Other External Devices
- Supply Fan Interlock Contacts 15
- Fire/Fault Contacts 15
- Fan Calibration 16
- Aiming the Nozzles 17
- Operation 17
- Unit Pre-Suppression Functions 17
- Arming the System 18
- User Interface Navigation
- Hood Lights Operation 20
- Fan Operation 20
- Range Operation 20
- Fire System Discharge 21
- System Faults 21
- Service Settings 21-23
- Fire Prevention Tips 23
- Service and Maintenance
- Accessing Internal Components 24
- Fire System Diagnostics 25
- Fire System Shut Off Sequence 25
- Fire System Detect Mode 25
- Fire Alarm Sequence 26
- After Actuation 26
- Routine Maintenance 27
- Troubleshooting 28-29
- Parts List 29
- Our Commitment Backcover

Model Number Code

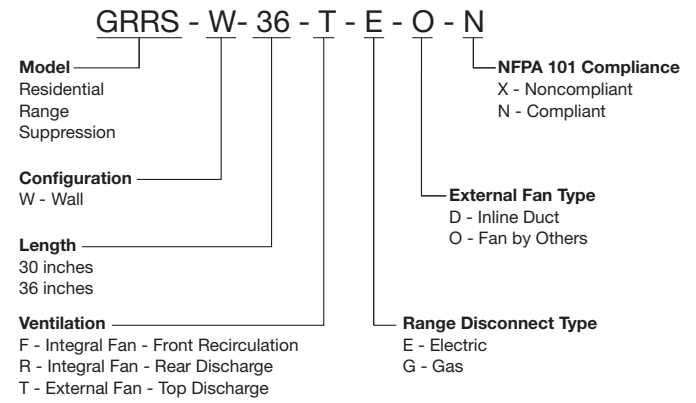

Example: GRRS-W-36-T-E-O-N
Greenheck GRRS, wall mount, 36 inches long, with top discharge, with electric element disconnect, fan provided by others, NFPA 101 Compliant

Hood Exploded View

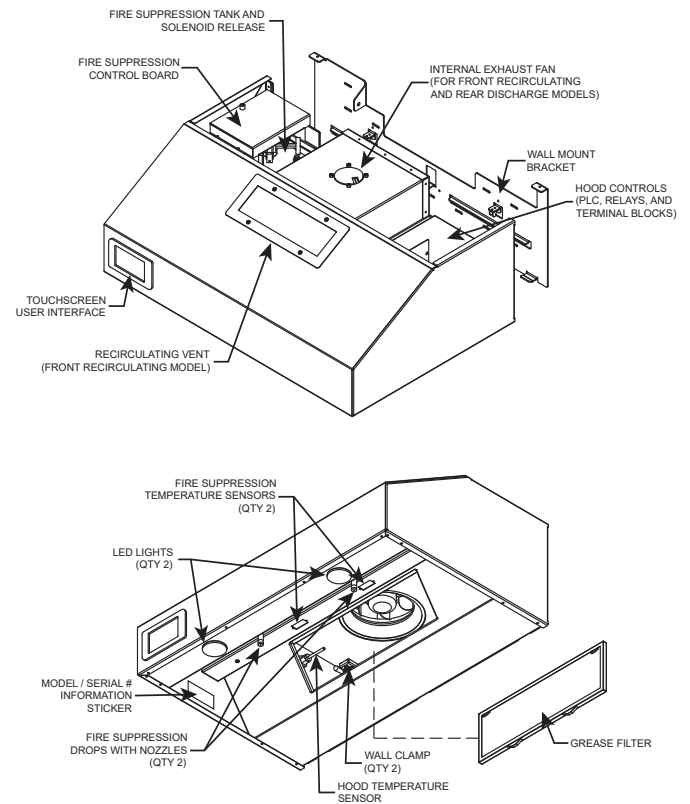

Ventilation and Fan Type Configurations

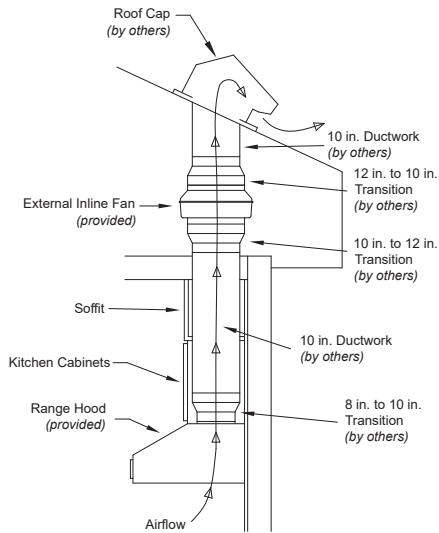

**External Fan | Top Discharge
(with Non-NFPA 101 Compliant Inline Fan)**

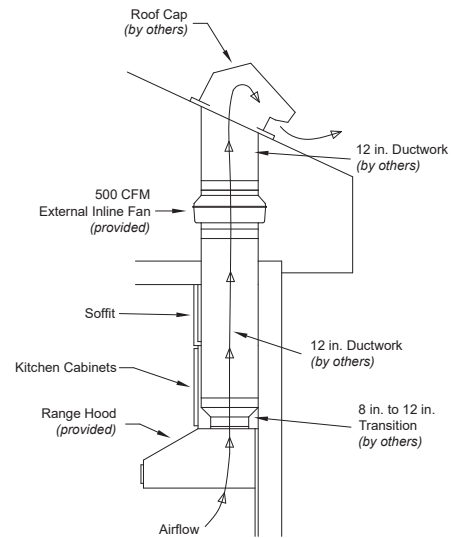

**External Fan | Top Discharge
(with NFPA 101 Compliant 500 cfm Inline Fan)**

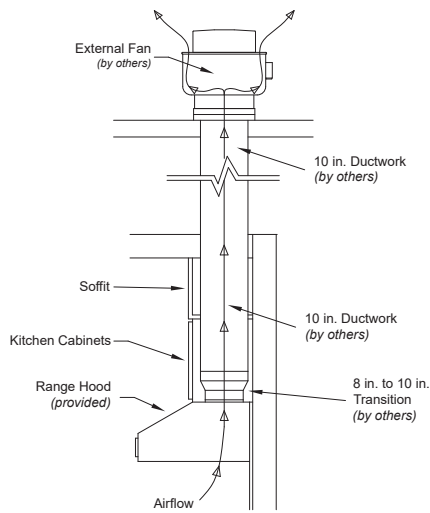

**External Fan | Top Discharge
(with Non-NFPA 101 Compliant Fan by Others)**

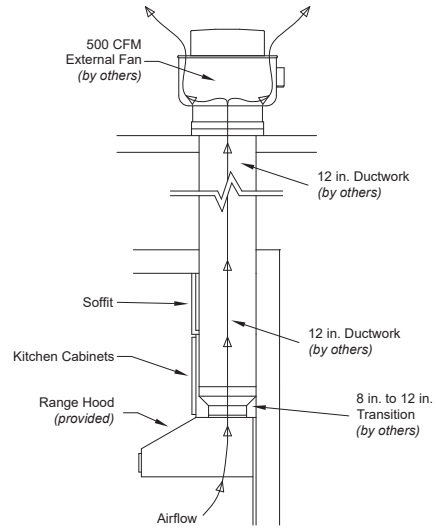

**External Fan | Top Discharge
(with NFPA 101 Compliant 500 cfm Fan by Others)**

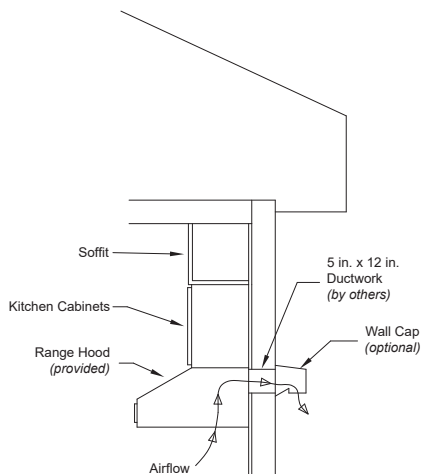

Integral Fan | Rear Discharge

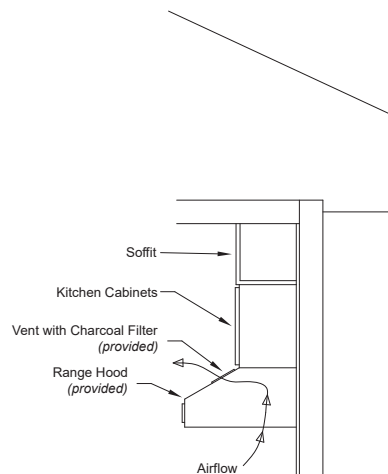

Integral Fan | Front Recirculation



Wiring Diagram: Electric Disconnect

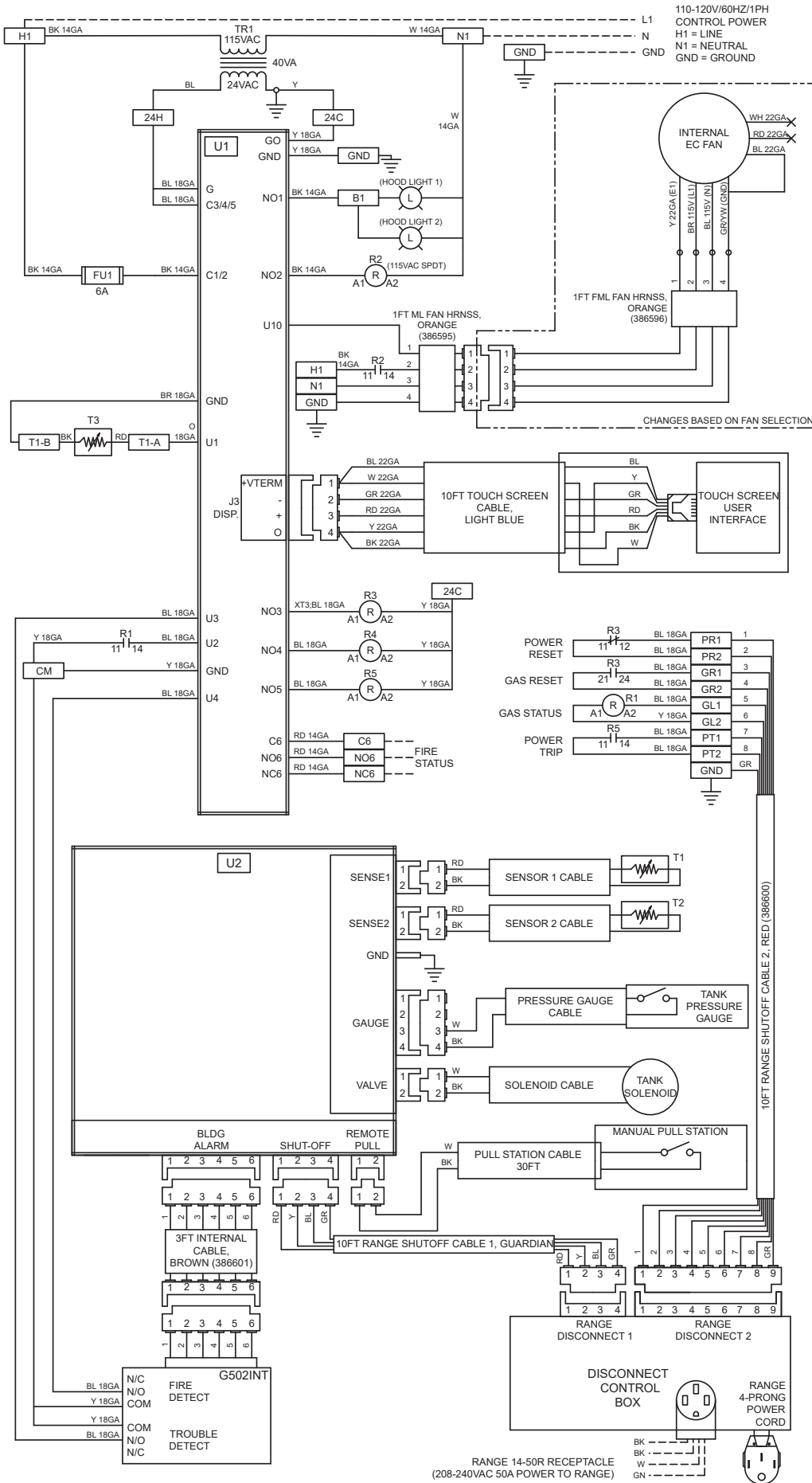

Wiring Diagram: Gas Disconnect

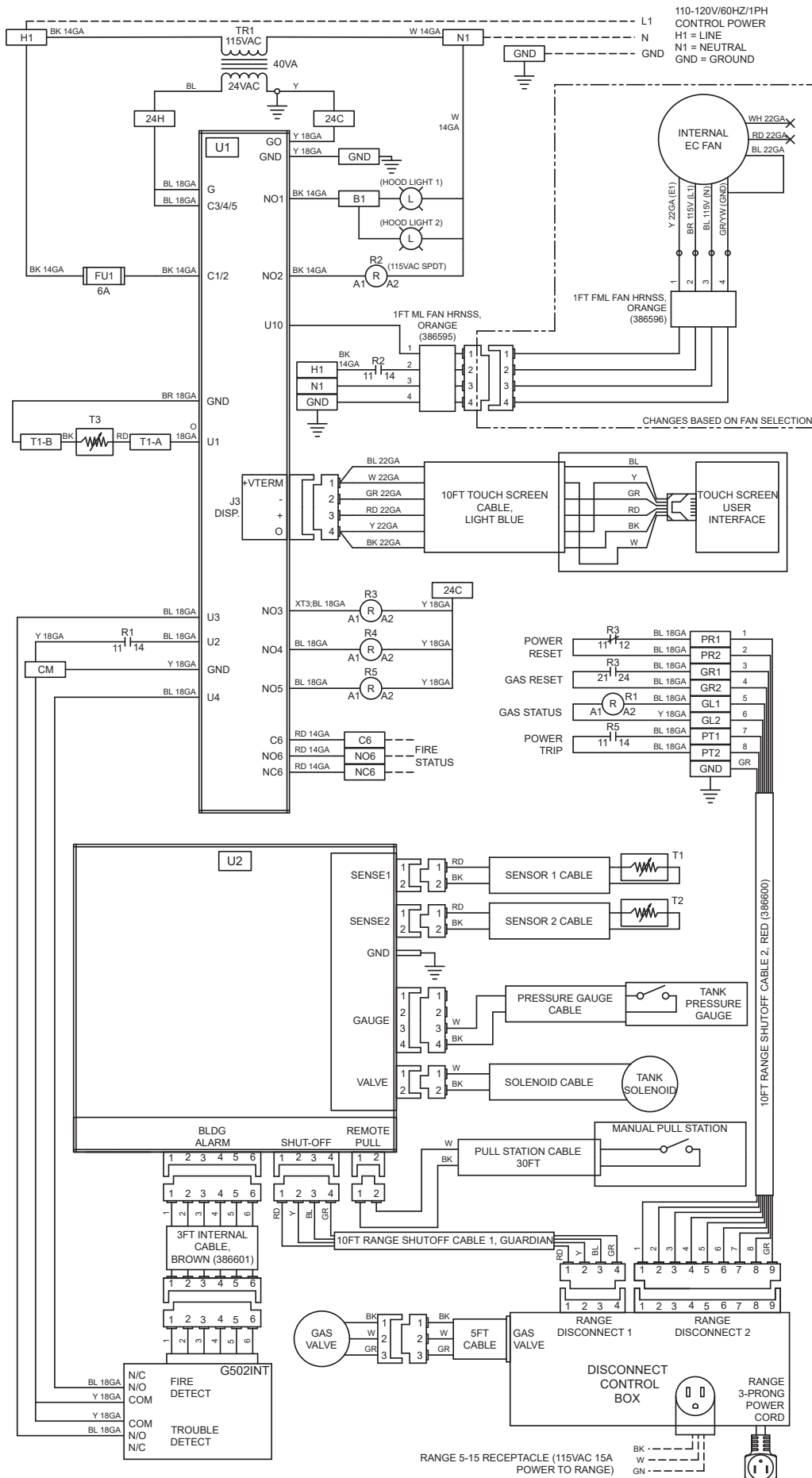

Installation

WARNING		
Failure to affix the mounting bracket to studs correctly can lead to structural damage and/or serious injury. The structural integrity of the wall is the responsibility of the contractor.	Hood Weight	
	30 inches	86 lbs.
	36 inches	93 lbs.
AVERTISSEMENT		
Si le support de fixation est mal posé sur les montants, il peut y avoir des dommages structuraux et/ou de graves blessures. L'entrepreneur est responsable de l'intégrité structurale du mur.	Poids de la hotte	
	76 cm (30 po)	39 kg (86 lb)
	91,4 cm (36 po)	42,2 kg (93 lb)

It is recommended that before drywall is hung, all electrical cables that need to be run within the wall should be run through the wall to their corresponding components. Mount the control j-box to line up with the right corner of the hood mounting bracket and run cables for these components into this box through the grommets. Confirm all critical mounting points will need to be secured through studs or utilize dry wall hangers. Hood weight should be supported by at least two (2) studs. Hood needs to be centered above the range and within the height requirements shown. Make sure that with integral fan – rear discharge configurations, the studs and control j-box (see picture on right) do not interfere with the rear discharge duct.

After drywall is hung, affix mounting bracket to wall using the necessary field provided fasteners through the critical mounting points.

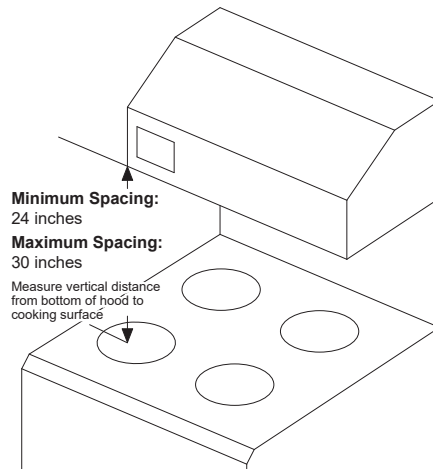

Hood to Cooking Surface Spacing Recommendation

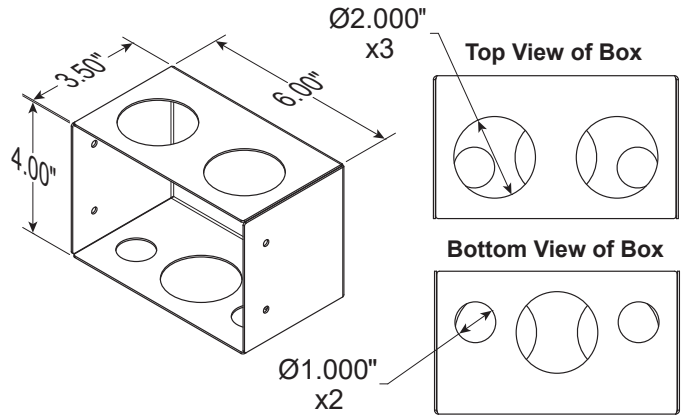

Control J-Box Dimensions

Dimensional Data

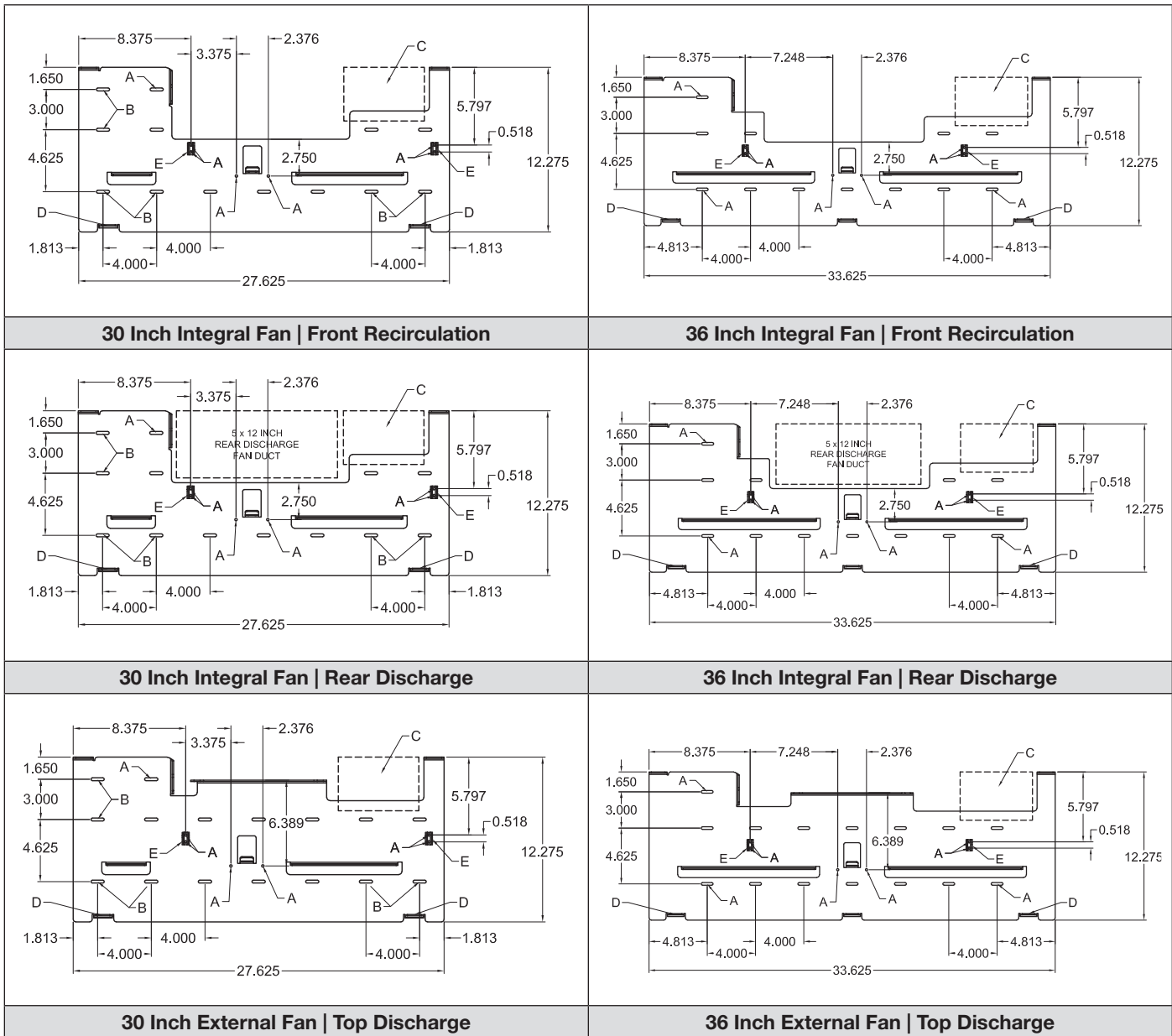

Dimensions shown are in inches.

Mounting Bracket Key	
A	Critical mounting points must be secured to studs or drywall hangers
B	Utilize one of these two critical points for securing to stud or drywall hangers. (Three total)
C	Location for factory provided 4 inch high x 6 inch wide x 3-1/2 inches deep control j-box
D	Hood support tabs
E	Hood latch catch mounting points must be secured to studs or drywall hangers

1. Before mounting, situate mounting bracket on wall making sure critical mounting points are met and distance from bottom of bracket to cooking surface is between 24 and 30 inches.
2. Cut out space in wall for factory provided control j-box and secure in place.

3. Secure mounting bracket to wall using the proper field provided fasteners through all critical mounting points shown in the drawings. Select fasteners that will properly support the total weight of the hood (hood weight shown on page 7).
4. Secure factory provided hood latch catches to wall using the proper field provided fasteners through all mounting points shown in the drawings. Proper orientation should have the latch "hooks" pointing down - see image.

(2) Fasteners attaching latch catch and wall mount to the wall

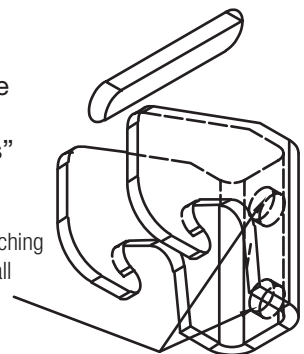

Ductwork (if applicable)

Running ductwork will be required for hoods configured for external fans. A small rectangular piece of duct spanning the width of the wall will be required for integral fan – rear discharge configurations (discharging through the back wall). For integral fan - rear discharge, the duct cannot be permanently attached to the hood, as the hood does drop into a service position, so we recommend using a high temperature gasket where the back of the hood and rear duct through the wall meet to provide a good seal during operation. Check the individual hood drawings to see what fan type is provided with your system.

Hood Length (in.)	NFPA 101 Compliance	Ventilation	External Fan Type	CFM	Duct Size (Minimum)	Duct Length (Maximum)
30	No	Integral Fan – Front Recirculating	Not applicable	250	Not applicable	Not applicable
	No	Integral Fan – Rear Discharge	Not applicable	250	5 x 12 in.	2 ft.
	No	External Fan - Top Discharge	Inline	250	10 in. round (diameter)	35 ft.
	No	External Fan - Top Discharge	Fan by Others	250	10 in. round (diameter)	External fan by others should be sized based on hood and duct static pressure
	Yes	Integral Fan - Rear Discharge	Not applicable	500	5 x 12 in.	2 ft.
	Yes	External Fan - Top Discharge	Inline	500	12 in. round (diameter)	35 ft.
	Yes	External Fan - Top Discharge	Fan by Others	500	12 in. round (diameter)	External fan by others should be sized based on hood and duct static pressure
36	No	Integral Fan – Front Recirculating	Not applicable	300	Not applicable	Not applicable
	No	Integral Fan – Rear Discharge	Not applicable	300	5 x 12 in.	2 ft.
	No	External Fan - Top Discharge	Inline	300	10 in. round (diameter)	35 ft.
	No	External Fan - Top Discharge	Fan by Others	300	10 in. round (diameter)	External fan by others should be sized based on hood and duct static pressure
	Yes	Integral Fan - Rear Discharge	Not applicable	500	5 x 12 in.	2 ft.
	Yes	External Fan - Top Discharge	Inline	500	12 in. round (diameter)	35 ft.
	Yes	External Fan - Top Discharge	Fan by Others	500	12 in. round (diameter)	External fan by others should be sized based on hood and duct static pressure

All ductwork will need to be provided in the field. Installing ductwork must be done by qualified person(s) in accordance with all applicable codes and standards, including fire-rated construction. All ductwork, per IMC Section 505 should be constructed of sheet metal, have smooth inner walls, be air tight, and be independent of all other exhaust ductwork systems.

To minimize static pressure losses and promote adequate airflow, minimize duct run lengths where possible.

For external fan configurations, duct should be connected to the 8 inch collar adapter on the hood mounting bracket. Transitions should be utilized to expand duct to duct size minimum requirements noted in table above.

Hood

1. Remove hood from crating. Remove the grease filter.
2. Carefully lift it onto the lower hood tabs on the wall mounting bracket.
3. While holding the hood up, hook the safety cable to the chain link on the mounting bracket and screw nut to close the link. The hood is now in the service position.
4. To put the hood into operation position, lift the hood up, and one at a time re-hook the clamps and pull the clamps tight until they lock. Make sure the safety bolt lever is located inside the notch in the hood mounting bracket. See page 22 for pictures and more information.
5. When all construction is complete, remove protective plastic sheeting from hood stainless steel. Clean (using alcohol and rag) and polish (using stainless steel polish) the hood. When cleaning or polishing, be sure to wipe with the grain and not against it.

External Fan (if applicable)

External Fan – In-line

Install fan vertically or horizontally in ductwork running between the unit and roof cap. Make sure the fan installed with the airflow arrow on the side of the fan directed away from the hood (to the outside).

For best results, use as few elbows or transitions as possible. If necessary, long radius elbows or bends are recommended.

To attach ductwork, use duct tape at inlet and outlet to assure a good seal. If using fan clamps, attach clamps and insert screws through clamp into inlet and outlet flanges.

CAUTION

Use sheet metal screws to secure ductwork to inlet and outlet. It is critical that the screw penetrate the metal of the flange, but not so far as to bind the impeller. It may be necessary to angle screws away from impeller.

ATTENTION

Utiliser des vis autotaraudeuses pour fixer le réseau de gaines à l'entrée et à la sortie. Il est essentiel que la vis pénètre le métal du rebord, mais pas assez pour faire saisir la turbine. Il peut être nécessaire de faire dévier les vis pour les éloigner de la turbine.

External Fan – Fan By Others

Follow all installation instructions provided with the fan.

Range Disconnect

Gas (if applicable)

1. Locate gas shut off assembly box and gas valve.
2. Using the four (4) appropriate sized fasteners, mount and fasten gas shut off assembly box behind range through mounting holes provided. Unit dimensions shown:

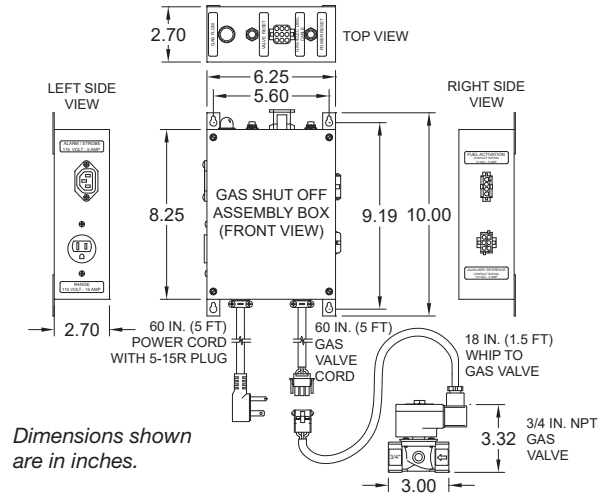

NOTE

Cables provided to connect the gas and electric assembly boxes back to the hood are 10 ft. long. Do not mount the gas shut off assembly box too far away from the hood, as these cables will not reach. Make sure to mount shutoff within 5ft of 115VAC 5-15 outlet.

3. If not already done, plug gas valve 1.5 ft. whip into 5 ft. gas valve cord coming off of bottom of the gas shut off assembly box. Install 3/4 inch (NPT fittings) gas valve in-line with gas line to range.
4. Follow electrical installation instructions for gas range disconnect on pages 13 and 14.

Electric (if applicable)

1. Locate electric shut off assembly box.
2. Electric shut off assembly should be situated behind the range (on floor) or in cabinet next to range. Unit dimensions shown:

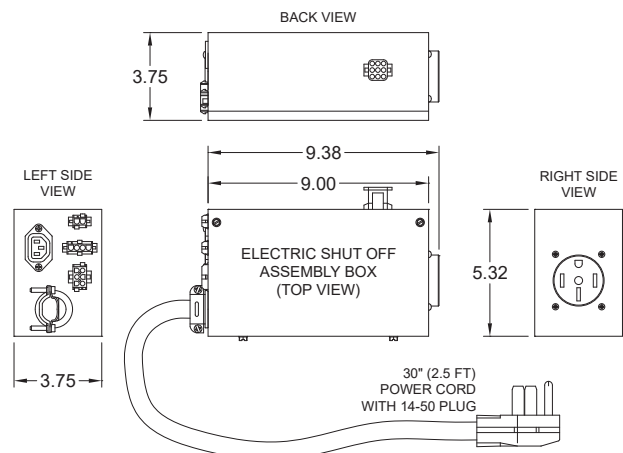

3. Follow electrical installation instructions for electric range disconnect on page 14.

Accessories

Remote Mounted User Interface (if applicable)

Skip these steps if the user interface is factory mounted on the hood.

1. Recess mount the user interface box near hood (cable provided is 10 feet in length).
2. Follow electrical installation instructions for remote mounted user interface on pages 13 and 14.

NOTE

To comply with ADA standards, interface (if mounted on an unobstructed wall) must be a max of 48 inches off of the finished floor.

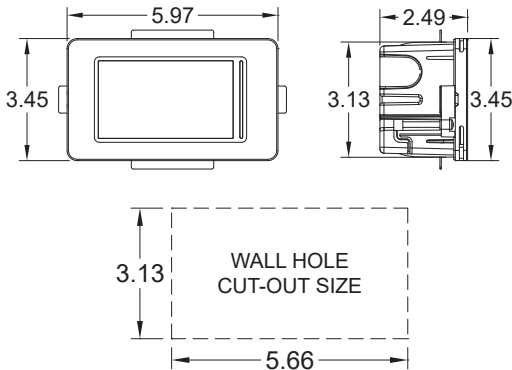

Dimensions shown are in inches.

Finished Top (if applicable)

A finished top can be included with all integral fan configurations when there are no cabinets covering the top of the hood. If provided with a finished top, the top piece will be attached to the hood when shipped.

1. Remove the finished top piece after mounting the hood. Once the hood is fully installed and armed, fasten the finished top piece to the top of the hood using fasteners provided.

Ceiling Enclosures (if applicable)

Ceiling enclosures may be included with the system to close off the top of the hood when configured for external fan – top discharge, to hide ductwork if no kitchen cabinets enclose the top of the hood.

1. Remove screws that attach enclosure mounts to enclosure panels.
2. Fasten enclosure through pre-drilled holes to wall using appropriate field provided fasteners.
3. Attach enclosure panels to enclosure mounts using the screws removed in step 1.

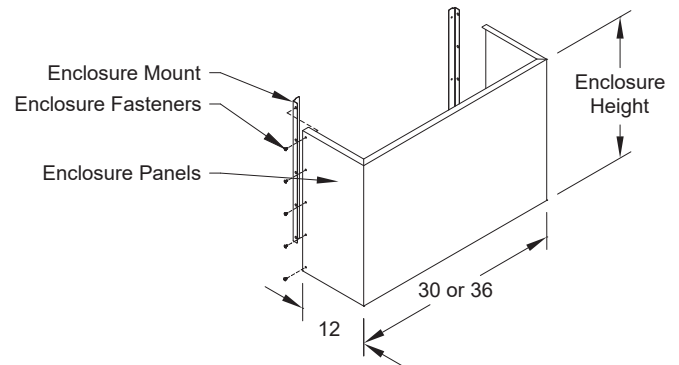

Dimensions shown are in inches.

Wall Cap (if applicable)

A wall cap with built in birdscreen and damper may be provided for internal fan – rear discharge hood configurations that exit the building through an external wall.

1. Once wall mounting bracket is installed, cut hole in wall and install 5 x 12 inch duct to line up with hood opening.
2. On outside wall, affix wall cap to cover duct opening. Seal all joints to prevent air and water leaks.

Dimensions shown are in inches.

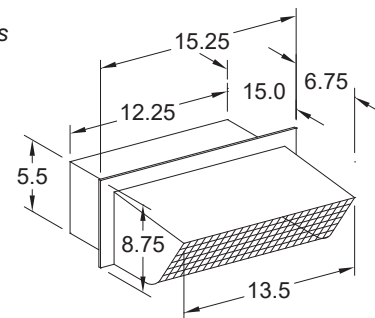

NOTES:

1. Steel construction with black enamel finish
2. For outside wall applications
3. Built-in birdscreen and damper
4. To use with 5 x 12 inch duct (provided by others) with internal fan - rear discharge hood configuration

Manual Pull Station (if applicable)

A manual pull station may be included to manually trigger and discharge the hood fire suppression

1. Surface mount the manual pull station near the hood within the path of egress (cable provided is 30 feet in length).
2. Follow electrical installation instructions for manual pull station on page 15.

NOTE

To comply with ADA standards, pull station (if mounted on an unobstructed wall) must be a max of 48 inches off of the finished floor.

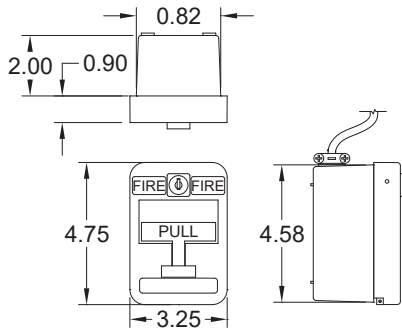

Dimensions shown are in inches.

Horn Strobe (if applicable)

If the facility does not have a fire alarm panel, the horn strobe can provide visual and audible notification of a fire.

1. Surface mount the horn strobe near the hood (cable provided is 8 feet in length).
2. Follow electrical installation instructions for horn strobe on page 15.

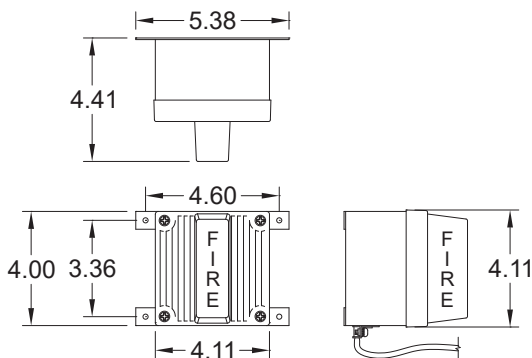

Dimensions shown are in inches.

Fire Extinguisher (if applicable)

The system may be provided with a separate K-Class, 6 liter wet chemical fire extinguisher.

1. Surface mount the extinguisher per NFPA and local code requirements.

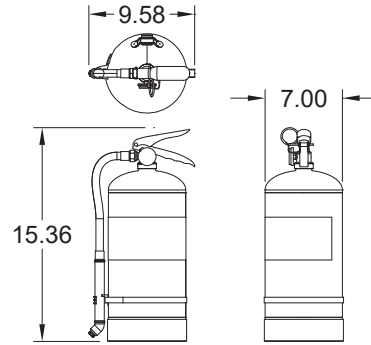

Dimensions shown are in inches.

Electrical Connections

CAUTION

Electrical installation should be performed by a licensed electrician. Shut off power at the main breaker to prevent electrical shock when accessing electrical connections. All field installation and wiring of electrical equipment must be done to meet NEC and local codes.

ATTENTION

Confier les travaux d'installation électrique à un électricien qualifié. Couper l'alimentation électrique au disjoncteur principal pour éviter des chocs lorsqu'il faut avoir accès aux connexions électriques. Toute l'installation en chantier et câblage de l'équipement électrique doivent être effectués conformément au code national de l'électricité et aux codes locaux.

Hood Power

1. Run 115VAC from 15A breaker through a one inch knockout in the control j-box behind the hood mounting bracket, then into the hood.
2. Land the hot on terminal H1, neutral on terminal N1, and ground on green GND terminal. Make sure there is enough slack in the wire to prevent tension on it when the hood is dropped in the service position; the hood should be supported by the safety cable and link and not by electrical wiring.

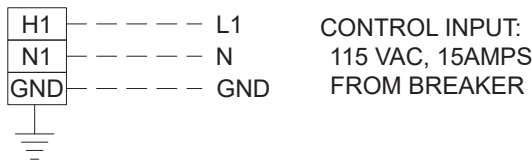

Fan Power

Integral Fan – Front Recirculation or Rear Discharge

If provided with an internal fan, the fan will be wired from the factory.

External Fan – Inline

If provided with an external inline fan, the hood will be provided with a 50 ft. 4-wire plug and play cable with an orange label. Connect this cable to the **orange** plug and play harness at the fan, run it down to the hood and through a two inch knockout in the controls j-box. Connect to the orange plug and play harness in the hood.

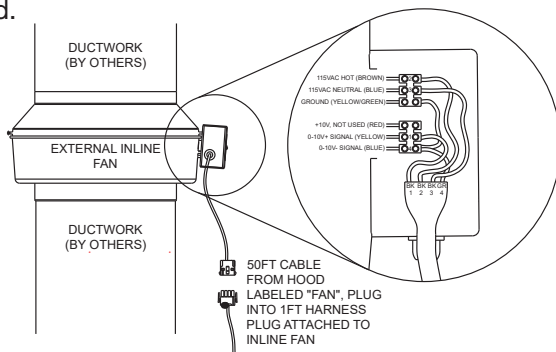

External Fan – Fan by Others

If configured for an external fan by others, there will be a 50 ft. 4-wire plug and play cable with an **orange** label. Connect this to the orange harness in the hood, run it through a two inch knockout out of the controls j-box and out to the fan. Signals for each wire are shown:

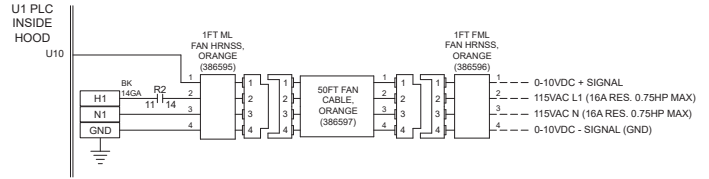

NOTE

115VAC on wires 2 and 3 in a 'fan by others' harness can drive a 115VAC motor with a max HP of 0.75. If driving a motor larger than 0.75HP, utilize this signal to drive a 115VAC-coil motor starter with contacts that can handle larger amperages (motor starter to be provided by others).

Range Disconnect

Gas (if applicable)

1. If gas range has a 115VAC cord, plug this cord into the gas shut off assembly box 115VAC receptacle labeled "RANGE".

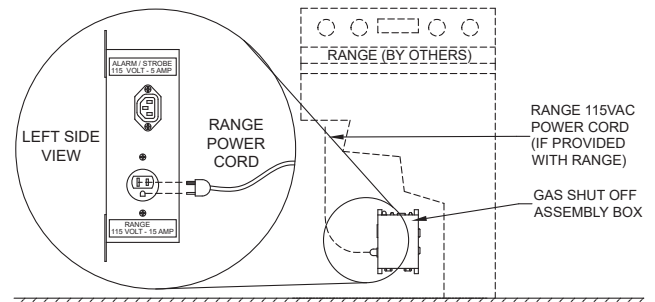

2. If not already done, plug gas valve 1.5 ft. whip into 5 ft. gas valve cord coming off of bottom of the gas shut off assembly box.

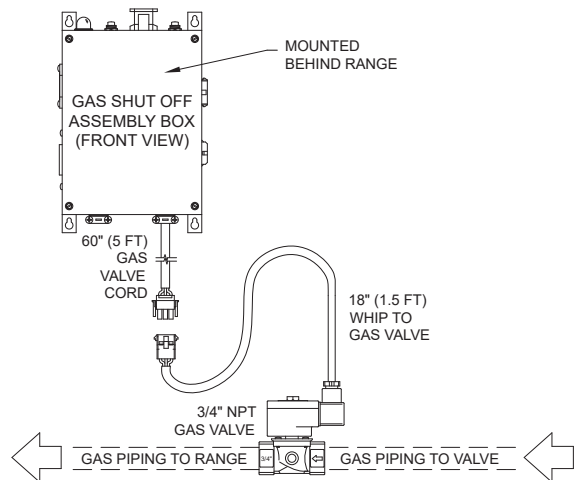

3. Plug gas shut off assembly box (5 ft. power cord) into 115VAC 5-15 receptacle near the range.

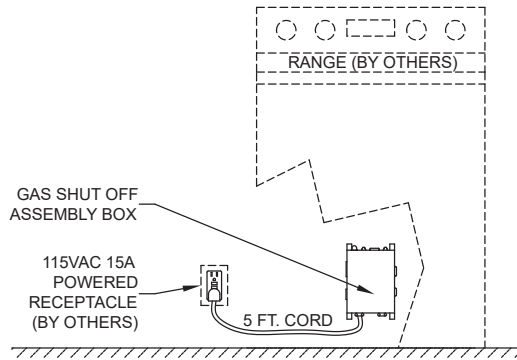

4. There will be (2) 10 ft. plug and play cables for controlling the shut off assembly box. The 9 wire cable will be factory connected to the fire ready hood. The 4 wire cable will be shipped loose. Run these through a two inch knockout in the control j-box down to the gas shut off assembly, connecting them per the diagram shown:

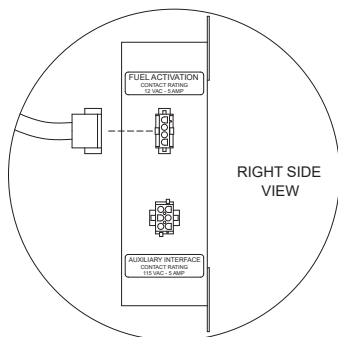
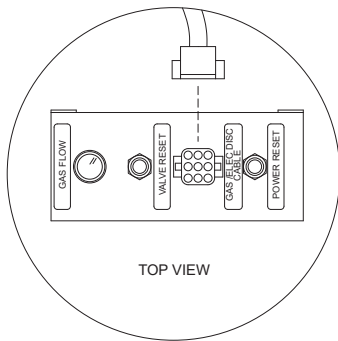
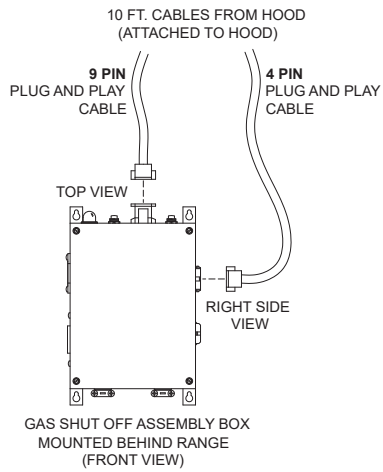

Electric (if applicable)

1. Plug range power cord into 250VAC receptacle on electric shut off assembly box.

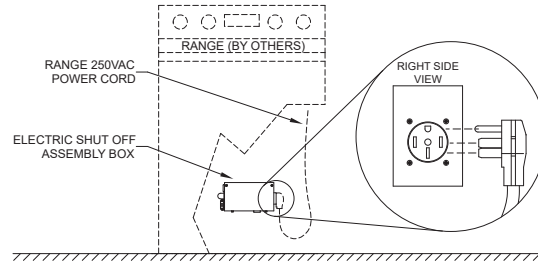

2. Plug electric shut off assembly box (2½ ft. 4-prong power cord) into 250VAC 14-50 receptacle near the range.

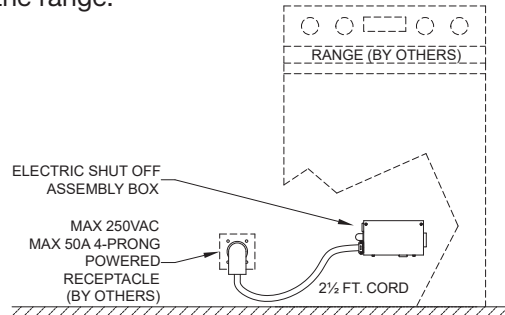

3. There will be (2) 10 ft. plug and play cables for controlling the shut off assembly box. The 9 wire cable will be factory connected to the fire ready hood. The 4 wire cable will be shipped loose. Run these through a two inch knockout in the control j-box down to the electric shut off assembly, connecting them per the diagram shown.

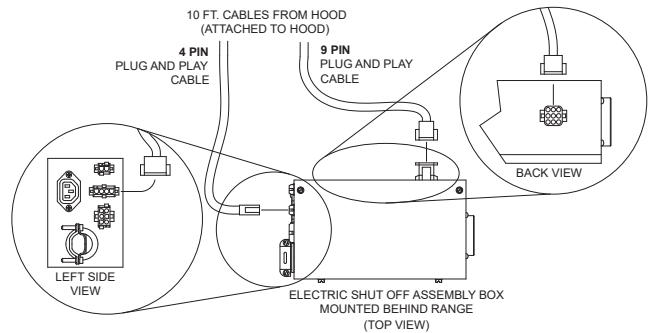

Accessories

Remote Mounted User Interface (if applicable)

There will be one 10 ft. plug and play cable with an **light blue** label attached to the hood. Run the cable through a one inch knockout in the controls j-box, run behind the wall and connect to the back of the user interface. Mounting instructions can be found on page 11.

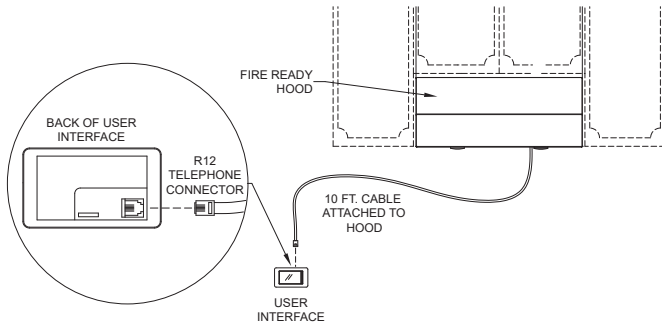

Manual Pull Station (if applicable)

Manual pull station will be provided with a 30 ft. plug and play cable. Run this behind the wall through a one inch knockout in the controls j-box, then into the hood and connect to “REMOTE PULL” port on fire suppression control board.

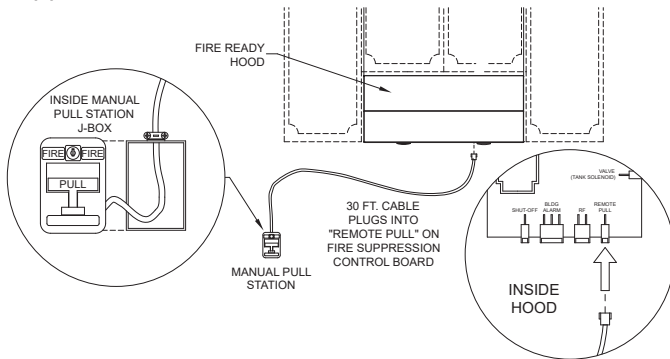

Horn Strobe (if applicable)

There will be one 8 ft. cable with flying leads attached to the horn strobe. Wire 115VAC hot to terminal block C6, attach black wire from horn strobe to NO6, and attach white wire back to 115VAC neutral. You may share 115VAC with main hood power (115VAC power available between terminals H1 and N1).

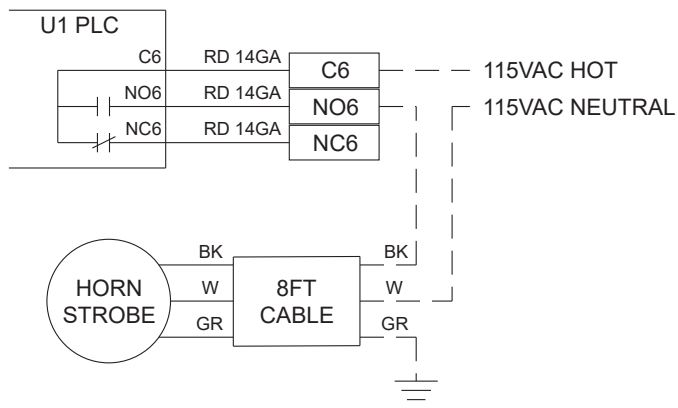

Other External Devices

Supply Fan Interlock Contacts

1. R and G terminal
2. Dry, normally open contact closes when supply fan should run – can be used to drive a device that controls a supply fan if MUA is necessary
3. Contacts rated to 8A and 250VAC

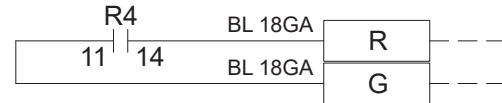

Fire/Fault Contacts

NOTE

Fire/Fault Contacts are default to switch state upon fire discharge **ONLY**, but can be changed to switch state upon both a fire discharge **OR** a fire trouble (fault). See page 23 for details on changing this if desired.

NOTE

These contacts are intended to be used for notifying building fire alarm **OR** for connecting to horn strobe (see horn strobe electrical connections on this page).

1. C6 and NO6 terminal blocks - Dry, normally open (N.O.) contact closes on fire/fault
2. C6 and NC6 - Dry, normally closed (N.C.) contact that opens on fire/fault
3. Contacts rated to 8A and 250VAC

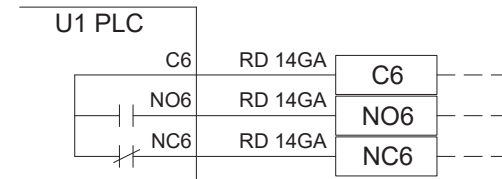

Fan Calibration

NOTE

Integral fan – front recirculating models shouldn't have to be calibrated, as these require no added ductwork. Fan calibration is necessary for integral fan – rear discharge and external fan configurations (both inline and fan by others).

NOTE

To avoid poor hood performance, it is important for the hood to be balanced for the designed CFM. For NFPA 101 compliant models, 500 designed CFM is required.

Once hood and fan (if external) is installed and powered, navigate into the service menu on the user interface. Navigation instructions can be found on pages 20-21. Press the “Balance Exhaust Fan” button, and fan will turn on and ramp to full speed.

Once fan is on, connect one end of manometer to plenum pressure port (1/8 inch MNPT barb located near grease filter) and take reading. Adjust the max speed as necessary to match the pressure with the corresponding value on the screen (or reference the table below based on your hood size and configuration).

For example, for a 36 inch, non-NFPA 101 compliant, external fan – top discharge, inline fan configuration model, to obtain the designed 300 CFM, we need the plenum pressure reading to be 0.25 in. wc.

Hood Length (in.)	NFPA 101 Compliance	Ventilation	External Fan Type	Plenum Pressure Reading for Designed CFM	High CFM	High Percent of Max CFM	Low Percent of Max CFM	Approximate Low CFM
30	No	Integral Fan – Front Recirculating	Not applicable	.21	250	70%	60% (Default)	150
		Integral Fan – Rear Discharge	Not applicable	.27	250	50%		150
		External Fan - Top Discharge	Inline	.13	250	100%		150
		External Fan - Top Discharge	Fan by Others	.13	250	100%		150
	Yes	Integral Fan - Rear Discharge	Not applicable	.67	500	80%		300
		External Fan - Top Discharge	Inline	.34	500	100%		300
36	No	Integral Fan – Front Recirculating	Not applicable	.28	300	80%		180
		Integral Fan – Rear Discharge	Not applicable	.20	300	50%		180
		External Fan - Top Discharge	Inline	.25	300	100%		180
		External Fan - Top Discharge	Fan by Others	.25	300	100%		180
	Yes	Integral Fan - Rear Discharge	Not applicable	.54	500	100%	300	
		External Fan - Top Discharge	Inline	.62	500	100%	300	
		External Fan - Top Discharge	Fan by Others	.62	500	100%	300	

Once balancing is complete, press the back arrow button to navigate back to the previous screen.

Aiming the Nozzles

NOTE

Aiming of the hood nozzles is typically performed by factory authorized fire equipment distributor during startup. Do not adjust after startup and arming has been performed.

1. Using a 1 inch box end wrench and crescent wrench, loosen the locking nut on the adjustable ball fitting on both nozzles.
2. Adjust the nozzle so they are angled at a point halfway between the center of the front and back burners.
3. After nozzles are correctly aimed, re-tighten the locking nut on both nozzles.
4. Recheck nozzles are aimed correctly.

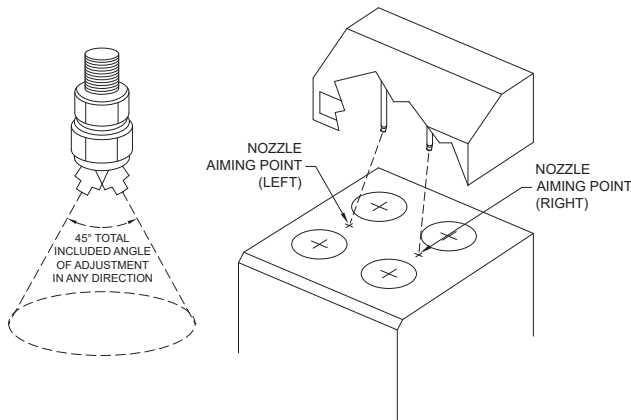

Operation

NOTE

System must be armed before operating per the instructions on page 18.

Unit Pre-Suppression Functions

The XRRS functions as a standard ventilation range hood with the added capability to suppress stove top fires.

Designed to use over a standard 30 and 36-inch domestic range, the system relies on input from a combination of sensors to control the fan and shutoff power to the stove when the temperature reaches preset points.

The fans and lights can be turned on and off using the user interface. The range can also be unlocked via the user interface. A password may be required to unlock (turn on) the range. The range may be automatically locked again after a time limit (default 2 hours) if the hood system was configured for NFPA 101 compliance. To comply with NFPA 101, this time limit cannot exceed 2 hours.

If the temperature reaches the cooking detection temperature setpoint (default 115°F), the hood turns the fan on (if not already on) and the fan speed control buttons are disabled. The speed of the fan is no longer controlled via the user, instead the fan is controlled via the hood temperature.

If the temperature continues to climb, upon the temperature reaching the high temperature setpoint (default 180°F), the hood will immediately lock (shut off) the range. An alarm will appear on the user interface warning the user of the high temperature. If fire/fault contact is configured for Fire System Discharge OR Trouble fault, the fault contacts at this point will switch state (see page 15 for terminal blocks and wiring information).

If the temperature continues to climb, upon reaching approximately 216°F, the fire suppression system will discharge, dispersing wet chemical on top of the appliance and suppress the fire below. If fire/fault contact is configured for Fire System Discharge Only, the fault contacts at this point will switch state (see page 15 for terminal blocks and wiring information).

Arming the System

NOTE

System arming is typically performed by factory authorized fire equipment distributor during startup. Do not tamper with the fire suppression system after the initial startup unless authorized to do so.

To arm the range hood, do the following:

- Once hood and hood components are installed, wired, and fan is balanced (if necessary), drop the hood into the service position, (instructions on page 22) and turn on all breakers feeding the hood and hood components.
- Remove the black cover from the fire suppression control board enclosure inside the hood (on left side of hood if looking at the hood front face).

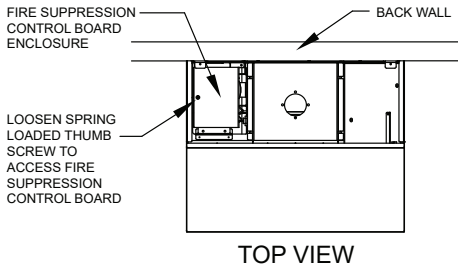

- With the cylinder pull-pin still installed in the agent tank (mounted beneath the fire suppression board), and 9V battery installed on the fire suppression control board, initiate a diagnostic test by press and release of the “RESET” button first, follow by press and release of the “TEST” button (also on the fire suppression board).

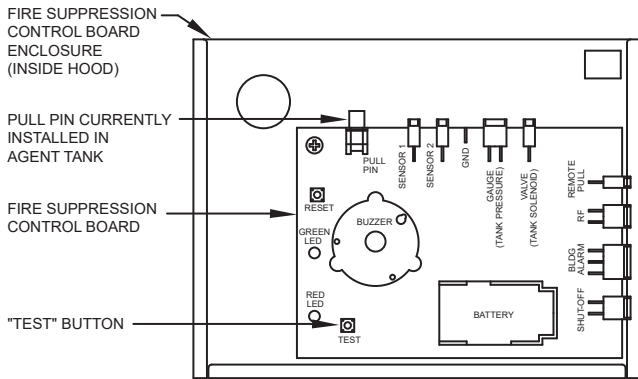

- The test should fail and issue six chirps, indicating that the pull pin has not been removed from the tank. If the result is a lesser number of chirps followed by the series of six chirps, then some item other than the pull pin has failed and the system should be troubleshot before proceeding further (see Diagnostic Failure Codes, page 25).
- After troubleshooting, re-test until only the 6 chirp diagnostic failure code occurs.
- Verify that the fuel shut-off is powered (breaker is on) and all burners on the range are off.
- Remove wing screws that hold the fire suppression control board enclosure in place above the wet chemical tank. Without disconnecting any cables, slide the control board assembly towards the middle of the hood and down so it's next to the tank, revealing the tank assembly.

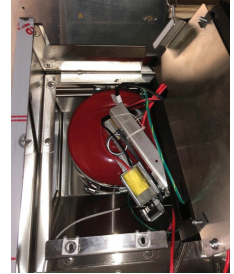

- Check and make sure the solenoid release latch is engaged and holding the release latch up, then remove the pull pin from the agent cylinder and insert the pull pin in its socket on the PCU board.

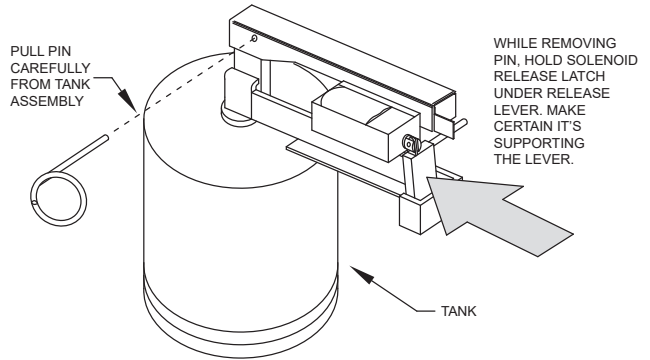

- If the push and release of the “RESET” button yielded a green light, leave the pull pin in the CPU. Unlock the range via the user interface.

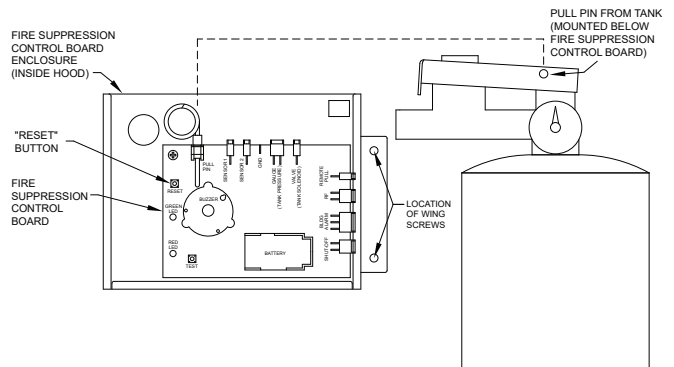

CAUTION

Carefully remove the pull pin from the tank, holding the release latch in place, as to not accidentally cause a fire system discharge.

ATTENTION

Retirer soigneusement la goupille du réservoir tout en maintenant le verrou de déblocage en place pour ne pas provoquer accidentellement une décharge du système d'extinction d'incendie.

10. The final step for verification is to turn on a range burner, then momentarily push and release the “TEST” button. If there are no failures detected, the fire suppression board will run a shutoff sequence (the alarm will sound for 10 seconds and shut off fuel to the stove followed by a chirp every minute). This allows complete verification of the system function all the way to the fuel shut-off but without the chemical agent dump. If the stove does not shut-off (burner shuts off and begins to cool down), additional troubleshooting is required.
11. Reset the CPU board by pressing the “RESET” button and confirm the green indicator momentarily lights up.
12. Make sure all burners are off, then unlock the range via the user interface.

User Interface (Touchscreen) Navigation

Home Screen

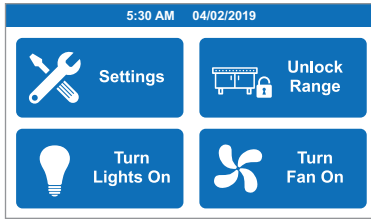

Hood Lights Operation

Press button with light bulb image on home screen to turn hood lights on and off.

Fan Operation

Press the button with fan blade image on the home screen to turn hood exhaust fan on and off. When fan is on and hood temperature is not above the Auto On Temp Setpoint (default 115°F), the user can press the “Fan High” or “Fan Low” buttons to force the fan into a low speed or a high speed as needed. When the fan is at low speed the indicator on the “Fan Low” button will illuminate orange. When the fan is at high speed the indicator on the “Fan High” button will illuminate orange.

NOTE

Fan will automatically turn on and be forced to high speed when hood temperature reaches the Auto On Temp Setpoint. Assuming the Auto Fan Off setting is enabled, if the hood temperature is above this setpoint and the user presses the “Turn Fan Off” button, the system will keep the fan on until the temperature drops below the cooking detection temperature setpoint and stays below this temperature for the Fan Auto Off Delay time (default 5 minutes).

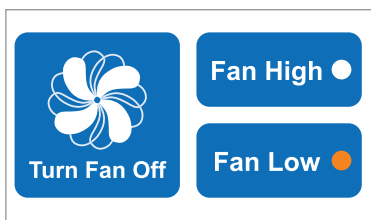

Example of fan on and at low speed



Example of screen as user attempted to shut off fan while fan is above cooking detection temperature setpoint.

Range Operation

Press the button on the home screen with the range and lock icon to unlock and lock the range. (Unlocking range allows it to be used for cooking, locking it prevents cooking from occurring).

NOTE

If the setting “PW (Password) and Auto Range Deactivate” is set to Enabled within the System Settings, the user will be prompted to correctly enter a 4-digit password upon attempting to unlock the range. Without a successful password entry the range will be unusable (locked). Once successfully unlocked, a timer will start (Range Auto Shut Off Time, defaulted for 2 hours), and once timer reaches 0, the range will automatically lock. To meet NFPA 101 life safety code compliance, PW/Auto Range Deactivate should be set to Enabled.

NOTE

If the hood temperature climbs above the high temperature alarm setpoint (default 180°F), the range will be automatically locked. This is represented by the range and lock button turning red. Only upon temperatures decreasing below the high temperature alarm setpoint can the range be unlocked again.



Example of successfully unlocked range with Password and Auto Range Deactivate enabled.



Example of temperature exceeding high temperature alarm setpoint.

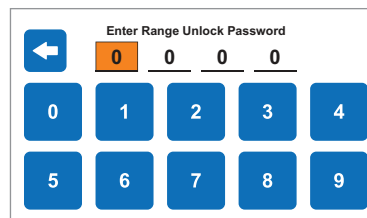

Range Unlock Password screen

Fire System Discharge

Upon a fire system discharge, the user interface will navigate to a screen displaying a flame icon and “Kitchen Fire Detected”. Pressing anywhere on the screen will navigate back to the home screen, but the kitchen fire detected alarm will still be present on the system until the fire system is recharged and reset.



System Faults

This list shows system faults that will appear in the top notification bar, replacing the date and time information, when they occur. If multiple faults are present on the system, each one will be displayed momentarily and cycle through the list. All system faults shown will shut off the range. All system faults except gas reset fault will prevent the range from being unlocked until the fault is corrected.

Fault	Description
High Temperature Alarm	Temperature in hood has exceeded high temperature alarm setpoint (default 180°F).
Fire System Trouble Detected	Fire system trouble contact has been engaged. Either a fire detection sensor is at fault, battery voltage is low, tank solenoid is not connected, tank pressure is low, or pull-pin is not inserted properly. See Fire System Diagnostics on page 25 for details.
Kitchen Fire Detected	Fire suppression temperature sensor has detected a fire, or manual pull station has been pulled.
Gas Reset Fault	Gas shut off assembly is not resetting upon attempting to unlock the range (gas ranges only).
Temperature Sensor Fault	Hood temperature sensor is not connected or is faulty.

Service Settings

Pressing “Settings” button on home screen will navigate to additional screens for parameter adjustments and a fault log.

Within these screens, blue arrow buttons pointed to the right will navigate to additional screens, and blue arrow buttons pointed to the left will escape back to the previous screen.

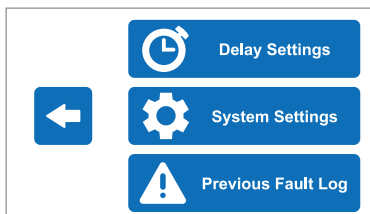

NOTE

Service menu is password protected and should only be accessed by technician or under the instruction of factory support. Default password is 1000.

A. Delay Settings

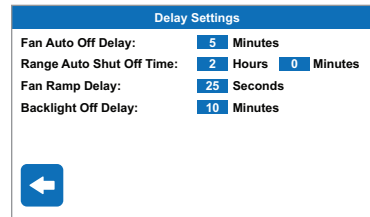

Fan Auto Off Delay: If hood temperatures exceed “Auto Fan On Temperature”, and user attempts to shut the fan off, the fan will not shut off until hood temperatures decrease back below Auto Fan On Temperature and stay below this threshold for the Fan Auto Off Delay time. (Default 5 minutes).

Range Auto Shut Off Time: If “PW/Auto Range Deactivate” is set to enabled, and range is unlocked, the range will be automatically shut off after the Range Auto Shut Off Time expires. (Default 2 hours). This is required for NFPA 101 Life Safety Code compliance.

Fan Ramp Delay: The amount of time it takes for the ECM fan to go through its start up procedure. (Default 25 seconds).

Backlight Off Delay: The screen will go dark after no touches are detected within the time delay to save the life of the screen. To make the screen light back up, simply press anywhere on the screen.

B. System Settings

i. Configuration

System Settings: Configuration	
Size:	30"
Disconnect Type:	Electric
NFPA 101 Compliant:	No
Ventilation Type:	Internal Fan - Front Recirc
PW/Auto Range Deactivate:	Disabled

Size: Hood length, selectable between 30 or 36 inches. (Default based on configuration).

Disconnect Type: Range utility disconnect type, selectable between electric or gas. (Default based on configuration).

NFPA 101 Compliant: Selectable between no or yes for NFPA 101 compliance. (Default based on configuration).

Ventilation Type: Selectable between Internal Fan – Front Recirculation, Internal Fan – Rear Discharge, or External Fan – Inline/By Others. (Default based on configuration).

PW/Auto Range Deactivate: Selectable between enabled or disabled, this provides password protection for unlocking the range, and automatically will shut it off after a countdown timer expires. (Default based on configuration).

ii. Setpoints

System Settings: Setpoints	
Min Fan Speed (% of Max):	60 %
Max Fan Speed:	70 %
Auto On Temp Setpoint:	115.0 F
Auto Fan Off:	Enabled
High Temp Alarm Setpoint:	180.0 F
Current Hood Temperature:	75.0 F

Min Fan Speed (% of Max): Percentage of maximum speed when fan is running at low speed. (Default 60%). For example if this is set to 60%, and max speed is set to 70%, the actual minimum speed setting will be 60% of 70%, or 42% (4.2VDC output control signal to ECM fan).

Max Speed %: Speed percentage when fan is running at max speed. (Default based on configuration)

This value can only be adjusted in the Balance Exhaust Fan screen. Press the “Balance Exhaust Fan” button to enter into this screen. See page 23 for details.

Auto On Temp Setpoint: When hood temperature reaches this setpoint, the fan (if not already on) will turn on, and force the fan to high speed. (Default 115°F).

Auto Fan Off: When enabled, this will allow the fan to shut off automatically if the fans are turned off manually when temperatures are above the Auto On Temp Setpoint, once the temperature decreases below the setpoint and stays below it for the Fan Auto Off Delay time. (Default Enabled).

High Temp Alarm Setpoint: Upon hood temperatures reaching this setpoint, the range will automatically be locked. (Default 180°F).

Current Hood Temperature: Displays current temperature of hood.

iii. General

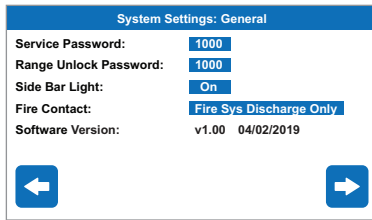

Service Password: Password for entering into service settings screens. (Default 1000).

Range Unlock Password: Password for unlocking range if PW/Auto Range Deactivate is enabled. (Default 1000).

Side Bar Light: Blue side bar light can be turned on or off. This helps indicate (when screen backlight turns off) that the hood is still operational to the user. (Default On).

Fire Contact: The dry fire contacts (terminal blocks C6, NO6, and NC6) typically used for building fire alarm panel integration can switch state in the event of either a fire system discharge only, or can be configured to switch state for both fire system trouble faults and fire system discharges. (Default is Fire System Discharge Only).

Software Version: This indicates the software version running on the system controller.

iv. Time and Date

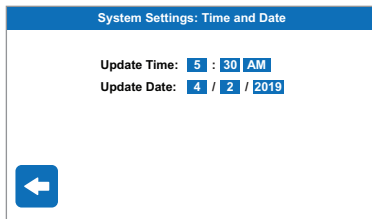

Update Time: Adjust time (hours, minutes, AM/PM) for system controller.

Update Date: Adjust date (months, days, year) for system controller.

C. Fault Log

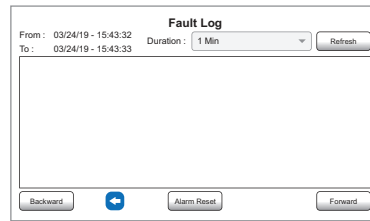

The fault log records and stores previous faults on the system. Press the blue arrow to navigate back to the Service Settings menu.

Balance Exhaust Fan (within Systems Settings: Setpoints)

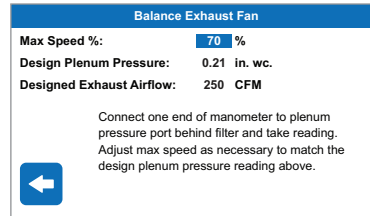

Upon entering this menu, the exhaust fan will turn on and ramp to the max speed percentage shown. Connect manometer to plenum pressure port, then adjust max speed value to match the manometer reading with the "Designed Plenum Pressure" reading on the screen in order to obtain "Designed Exhaust Airflow". When finished, press blue arrow button to navigate back to System Settings: Setpoints screen.

Fire Prevention Tips

If you must leave the kitchen when frying food, turn the burner off or remove the pan from the burner until you return.

In case of a grease fire:

NEVER attempt to move a pan of cooking grease that is already on fire from the kitchen range.

NEVER attempt to extinguish a grease fire with water. Instead, alert the other occupants and evacuate. Let the fire suppression system installed in the hood extinguish the range top fire. Wait at least 30 minutes after a cooking fire has been extinguished before approaching your range.

Service and Maintenance

Accessing Internal Components

NOTE

- All service on the fire suppression system should be performed by authorized equipment distributor.
- Do not drop the unit into service position while cooking on the range below.

WARNING

The hood is heavy. It is recommended to utilize multiple people to drop the hood into the service position; one person to support the hood while the other disengages latches inside, as to prevent the hood from causing injury.

ATTENTION

La hotte est pesante. Il est recommandé d'utiliser plusieurs personnes pour abaisser la hotte en position d'entretien, une personne supporte la hotte tandis que l'autre dégage les loquets intérieurs pour empêcher la hotte de blesser quelqu'un.

1. Pull down on the two tabs to release and remove the mesh filter from the filter track.



2. Behind the mesh filter, in the left and right corner of the plenum are two clamps holding the hood upright in the normal operating position. Press the red button on the bottom side of the clamp to unlock the clamp. Then pull the large red handle down. Release the clamps one at a time. Before releasing the second clamp, push up on the bottom front lip with one hand and use the other to release the second clamp.

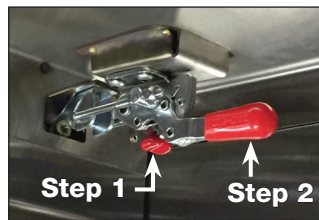

3. With both clamps released, release the safety bolt lever simply by pulling the black handle down. Keep upward pressure on the bottom of the front part of the hood while doing this. After releasing the safety bolt, the hood front will want to drop. Slowly lower the front of the hood until the safety cable is tight.

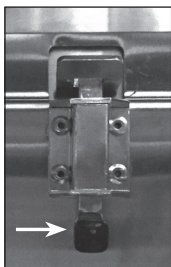

Safety Bolt Lever

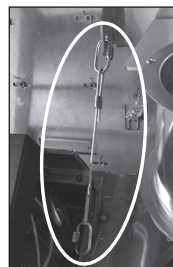

Safety Cable

4. Now the hood is in its service position. Any service to the fire system and interior components can be done at this time.
5. To put the hood back into operation position, lift the hood back up, and one at a time re-hook the clamps and pull the clamps tight until they lock. Make sure the safety bolt lever is located inside the notch in the hood mounting bracket.

Fire System Diagnostics

Pressing, then releasing the “TEST” button on the fire system control board will start a diagnostic test, putting the system into “test mode”. This is a way to verify that the entire system is working properly and the fuel shutoff function is working without discharging the fire suppression wet chemical.

Upon entering test mode and failing any particular test, a sequence of audible chirps will sound which represent a failure code (as well as a quick flash of the red indicator on the fire suppression control board). If multiple tests fail then you will hear multiple series of beeps with a pause in between each to identify multiple failure codes. Upon failing any part of the test, the control board will revert to a slowly flashing red indicator. If all six tests pass, the unit will enter a shut off sequence. (See next section, Fire System Shut Off Sequence).

Audible Diagnostic Failure Codes	
Number of Chirps	Corresponding Fire System Component Issue
1	Sensor 1 / Remote Pull
2	Sensor 2
3	Battery Voltage Low
4	Solenoid
5	Low Pressure
6	Pull-Pin

Upon any diagnostic failure, the fire ready touchscreen will generate a red border and show “Fire System Trouble Detected”. If a fire system trouble detected fault has been triggered, one must press “RESET” button on fire system control board, then test again.

Fire System Shut Off Sequence

A shut off sequence will cause:

1. 10 second audible alarm
2. Disconnect fuel from range
3. Following the 10 second audible alarm, the unit will issue one chirp every minute to alert the owner that the fire suppression system needs to be serviced.

Six items can cause a shut off sequence:

1. Low battery indication has persisted for at least 4.5 hours
2. A test sequence was executed successfully (see Arming the System, page 18)
3. The pull-pin was removed from its socket while in fire detect mode
4. An open circuit was detected on one of the fire suppression temperature sensors while in fire detect mode
5. An open circuit was detected on the solenoid while in fire detect mode
6. Low pressure on tank cylinder detected while in fire detect mode (closed circuit on fault)

Fire System Detect Mode

Upon pressing the “RESET” button on the fire suppression control board (and successfully passing all six diagnostic tests), the fire suppression control board will display a solid green indicator for two seconds, then the unit will enter into fire detect mode.

NOTE

Powering the fire suppression control board by inserting the battery OR pressing and releasing the “RESET” button will cause the same action.

During fire detect mode the fire suppression control board will silently run all six diagnostic tests. If at any time one of these test fails (with the exception of a low battery), the fire suppression control board will begin a shut off sequence (see above, “Fire System Shut Off Sequence”). Upon a low battery OR if the fire system was left in TEST mode, there will be a short chirp to indicate low battery or control board is in TEST mode, which occurs once every minute. After 4.5 hours of a low battery indication, the unit will enter the shut off sequence.

During fire-detect mode, the main unit monitors two sensors to detect high temperature indicating a fire. If a fire is indicated, the fire system control board will issue a fire alarm sequence (see page 26, “Fire Alarm Sequence”).

Fire Alarm Sequence

A fire alarm sequence will only occur upon the detection of extremely high hood temperatures (approximately 216°), or when the remote pull station is pulled (if provided).

The fire alarm sequence causes:

1. Audible alarm
2. Fire system (wet chemical) discharge
3. Fuel shut off to disconnect fuel to the cooking appliance (if not already shut off due to a high temperature alarm).

NOTE

The fire alarm sequence can only occur when the fire suppression control board is running in fire detect mode.

NOTE

To mute the audible alarm, place the hood into service position, and press “RESET” button on fire suppression control board.

After Actuation

NOTE

A complete system inspection and servicing must be done immediately following a kitchen range top fire. Consult an authorized fire equipment company for service or proper procedure.

NOTE

All service on the fire suppression system after actuation should be performed by authorized equipment distributor.

CAUTION

Before replacing the wet chemical, the tank, release valve assembly, it is recommended to wear approved type of eye protection and rubber gloves.

1. Shut off power to range (via building breaker).
2. Clean up all wet chemical using soap and warm water with a sponge. Do not use vacuum cleaner.
3. Carefully drop the hood into the service position, remove the fire suppression control board enclosure cover, and remove the battery from the fire suppression control board.
4. Disconnect the tank cylinder release valve terminal wire connections from the fire suppression control board.
5. Remove the extinguisher cylinder assembly from the enclosure based by loosening the cylinder band.
6. Unscrew and remove the extinguisher cylinder manifold / siphon tube assembly from the extinguisher cylinder. Pour out any leftover wet chemical in the cylinder.
7. Refill extinguisher cylinder with 4.9 lbs. of wet chemical agent (part of recharge kit).

8. Flush out existing distribution assembly water to remove residual wet chemical and blow dry.
9. Replace the extinguisher cylinder manifold O-ring and reinstall manifold / siphon tube assembly into the extinguisher cylinder (part of recharge kit).
10. Connect a nitrogen supply line to the ¼ inch male quick connect fitting and pressurize to 100 PSI.

CAUTION

Do not use extinguisher cylinder gauge to determine when the intended charge pressure has been reached.

AVERTISSEMENT

Ne pas utiliser le manomètre du cylindre extincteur pour déterminer le moment où a été atteint la pression de charge prévue.

11. Reinstall the extinguisher cylinder assembly in the enclosure base.
12. Refer to the “Arming the System” section on page 18 to reactivate the system.

NOTE

Upon performing the fire system diagnostic test, additional components may need to be replaced as a result of the high temperatures and flames that occurred during the fire. Replace these parts as necessary (see “Parts” on page 29).

Performing Fire Test

NOTE

Fire “puff” test may be necessary or required per local AHJ. This test should only be performed by factory authorized fire equipment distributor after startup.

Before performing fire “puff” test, make sure fire test cylinder is installed. Test cylinder is PN: 483831. It needs to be charged with nitrogen in the field before being installed in the hood and performing the fire test.

Performing fire test can be done two different ways:

1. If provided with manual pull station, pull lever on pull station.
2. If not provided with manual pull station, use Fire Ready Test Tool (PN: 387126). Plug this test tool into REMOTE PULL port on the fire suppression control board. Pressing the red button on the Fire Ready Test Tool will initiate a fire condition, similar to the manual pull station.

WARNING

Do NOT heat up temperature sensors with heat gun to perform a fire test, as flame/heat applied directly to temperature sensors would run the risk destroying/damaging the temperature sensors, and replacements in this case would not be covered under warranty.

Routine Maintenance

	Monthly	Annually	Every 10 Years
Cleaning	Yes	Yes	—
Suppression Nozzles	Inspect	Inspect	—
Temperature Sensors	Inspect	Inspect	—
Extinguisher Tank	Inspect	Recertify	Replace

To clean hood, wipe grease from exposed metal surfaces on the hood interior using a clean, dry cloth. Stainless steel hood exterior surfaces should be cleaned with a mild detergent then polished with a high grade stainless steel polish to preserve the original luster.

Routinely remove metal mesh grease filter from the hood and clean using hot water and mild detergent.

NOTE

Never use abrasive cleaners or chemicals on hood surfaces. Never use chlorine based cleaners or iron wool pads to clean the hood. They may scratch or mar the material, allowing pitting and rust to form. Always rub with the grain of the stainless when cleaning.

Replace hood lights, sensors, and other components as necessary.

On front recirculation models, replace the charcoal filter routinely (as needed) to help catch cooking odor molecules when recirculating air back into the space.

Troubleshooting

Problem: Fan won't turn on	
Fan not turned on by user interface	Press fan button on user interface
External inline fan not connected	Connect external inline fan to plug and play cable
Fan by others not connected	Wire fan by others to flying leads on 50 ft. cable provided
Blown fuse	Check fuse FU1 (6A), and test. If blown, replace (Qty. 1 spare is shipped loose with unit)
Fan not wired correctly	Make sure 0-10VDC and 115VAC wires are not reversed. Confirm signals using voltage meter
Problem: Hood is spilling smoke	
Fan is not on	Turn fan on by pressing fan button on user interface
Hood not centered above range	Center range below hood
Fan is not calibrated	See "Fan Calibration", page 16
Appliance is not correct size/type for fire ready hood	Appliance must be residential range type and either 30 or 36 inches long (for 30 or 36 inch long hood configurations)
Problem: Range doesn't work	
Range not unlocked by user interface	Press range / lock icon button on user interface (and enter password, if necessary) to unlock range
Electric range disconnect not receiving power	Reset breaker for electric range, make sure electric range disconnect is plugged into outlet
Gas range breaker feeding disconnect assembly box tripped/off	Reset breaker for gas range, make sure gas range disconnect is plugged into outlet
Hood temperature exceeding high temperature setpoint	Decrease cooking/shut off range to allow heat to subside in hood capture tank
Fire suppression control board fault	Correct control board fault and reset board (see Fire System Diagnostics, page 25)
Electric/gas disconnect assembly box not wired	Confirm both 10 ft. plug and play control cables are connected between hood and disconnect assembly box
No gas flowing to gas range	Make sure all manual gas valves feeding gas line are on, confirm gas valve is receiving 24VAC voltage between black and white wires
Problem: Touchscreen user interface blank	
Touchscreen backlight time expired	After backlight off delay time (default 10 minutes, see page 20), screen will go blank. Press anywhere on the screen to make the screen light back up.
Hood is not receiving power	Check breaker feeding hood and reset if necessary. Check voltage between terminals H1 and N1 (should be 115VAC).
Touchscreen is not wired	Make sure 10 ft. cable provided is plugged into controller and back of touchscreen
Problem: Hood lights don't work	
Hood lights not turned on by user interface	Press light button on user interface
Blown fuse	Check fuse FU1 (6A), and test. If blown, replace (Qty. 1 spare is shipped loose with unit)
Bad hood light bulbs	Replace bulbs
Problem: Range randomly shut off	
If configured for "NFPA 101" or "PW/Auto Range Deactivation", after the range is unlocked it will automatically shut off in 2 hours (default).	Working per design
Problem: Horn strobe not working	
Horn strobe not wired	Check wiring for horn strobe
No fire detected	Horn strobe will only sound upon a fire detected

Problem: Interlocked supply fan not working

Incorrect wiring

Dry, supply fan contacts provided on R and G. This contact will close when exhaust is on and the system is not in fire.

Faulty relay

Test relay R4 (when supply is on, should have 115VAC between A1 and A2). Contacts rated for 250VAC and 8A. Make sure whatever is connected to terminals R and G does not exceed these ratings.

Parts List

Part Number	Description
483757	Distribution Assembly (2 Hoses & 1 "L" Assembly & 1 "T" Assembly)
483939	Nozzle (System requires 2)
483938	54 inch. Sensor (System requires 2)
483759	Charged Cylinder Assembly
483760	CPU Control Board and Enclosure Assembly
483831	Test Cylinder (must be charged with nitrogen in the field)
483832	Recharge Kit (with agent, spring, o-ring, and valve stem)
483747	Gas/Electric 4-pin 10 ft. Plug and Play Cable 1
483748	Alarm Interface Assembly
483749	Manual Pull Station (with 30 ft. Cable)
387037	Manual Pull Station Break Rod Replacement
484709	Manual Pull Station Key Replacement
483750	Horn Strobe (with 8 ft. Cable with Flying Leads)
1021454	Electric Shut-Off Assembly
1021455	Gas Shut-Off Assembly (Disconnect Box and 24VAC Valve)
483752	24VAC Gas Valve ONLY
483309	Metal Mesh 18x6-inch Grease Filter
483308	Charcoal Carbon 12.75 x 4.5-inch Filter (for Front Recirculating Hoods)
386391	LED Light Bulb (System requires 2)
386600	Gas/Electric 9-pin 10 ft. Plug and Play Cable 2 (with red label)
485534	Latch, Hook, 1.13x0.52, 14GA Galvanized
385247	Transformer, 120V, 40VA

Part Number	Description
483310	Internal Fan Replacement
1021821	External Inline Fan Replacement
386591	Plastic Black Bezel for Touchscreen User Interface
386592	User Interface Flush Mount Enclosure Box
386599	User Interface 10 ft. Plug and Play Cable (with light blue label)
481989	K-Class Fire Extinguisher
483306	Wall Cap
386601	3 ft. Fire Alarm Contact Cable (with brown label)
384925	Fan Control Temperature Sensor
386593	Fuse, 6 Amp (FU1 on Wiring Diagram)
384927	Relay,Base,16A,Finder 9701SPA (Relay R2 Base)
384928	Relay,115VAC,16A,SPDT,Finder (Relay R2)
383559	Relay,Base,10A,Finder 95853 (Relays R1,R3,R4,R5 Bases)
383561	Relay,24VAC,8A,DPDT,Finder 40528024000 (Relays R1,R3,R4,R5)
855060	Safety Cable Kit (Includes Link and Rope Lanyard)
Contact Factory	PLC Controller
Contact Factory	Touchscreen
386597	50 ft. External Fan Cable (with orange label)
386595	1 ft. Internal/External Fan Harness, to Hood Controls
386596	1 ft. Internal/External Fan Harness, to Fan
387126	Fire Ready Test Tool

Reference

Maintenance Log

Date _____ Time _____ AM/PM

Notes: _____

Date _____ Time _____ AM/PM

Notes: _____

Date _____ Time _____ AM/PM

Notes: _____

Date _____ Time _____ AM/PM

Notes: _____

Date _____ Time _____ AM/PM

Notes: _____

Date _____ Time _____ AM/PM

Notes: _____

Date _____ Time _____ AM/PM

Notes: _____

Date _____ Time _____ AM/PM

Notes: _____

Date _____ Time _____ AM/PM

Notes: _____

Date _____ Time _____ AM/PM

Notes: _____

Date _____ Time _____ AM/PM

Notes: _____

Date _____ Time _____ AM/PM

Notes: _____



Reference

Maintenance Log

Date _____ Time _____ AM/PM

Notes: _____

Date _____ Time _____ AM/PM

Notes: _____

Date _____ Time _____ AM/PM

Notes: _____

Date _____ Time _____ AM/PM

Notes: _____

Date _____ Time _____ AM/PM

Notes: _____

Date _____ Time _____ AM/PM

Notes: _____

Date _____ Time _____ AM/PM

Notes: _____

Date _____ Time _____ AM/PM

Notes: _____

Date _____ Time _____ AM/PM

Notes: _____

Date _____ Time _____ AM/PM

Notes: _____

Date _____ Time _____ AM/PM

Notes: _____

Date _____ Time _____ AM/PM

Notes: _____



Our Commitment

As a result of our commitment to continuous improvement, Greenheck reserves the right to change specifications without notice.

Product warranties can be found online at Greenheck.com, either on the specific product page or in the literature section of the website at Greenheck.com/Resources/Library/Literature.

Greenheck's Fire Ready Residential Range Hood, Model GRRS catalog provides additional information describing the equipment, available accessories, and specification data.

AMCA Publication 410-96, Safety Practices for Users and Installers of Industrial and Commercial Fans, provides additional safety information. This publication can be obtained from AMCA International, Inc. at www.amca.org.

