



ZS-300

ZS-300 NEMA 4X Housing

For AMB, GMB, LF, NFB, NFX, AFB, AFX, AF Series Actuators

Application

The ZS-300 (-1) NEMA 4X enclosures may be used with AMB, GMB, LF, NF, and AF Belimo actuators. They are intended for use primarily to provide protection against corrosion, windblown dust and rain, splashing water, hose-directed water; undamaged by the formation of ice on the enclosure. Type 304 stainless steel enclosures resist moisture, dust, salt, and corrosive chemicals, and are easy to keep clean for sanitary applications.

Operation

The ZS-300 enclosures are designed so that the required actuator may be easily mounted in the enclosure. The operating shaft and coupling are inserted from the backside through the rotating shaft seal. The actuator is fastened on the end of the operating shaft and secured at the end with an anti-rotation strap. Adjustable mounting brackets, if supplied, are assembled to the fixed mounting holes at the top and bottom of the enclosure with stainless steel nuts, bolts and lock washers. The direct drive coupling is designed for a 1/2" round or hexagonal shaft and secured with two square head set screws. Mounting brackets are adjusted and secured in place.

Ordering Information

ZS-300	304 stainless steel housing with mounting brackets
ZS-300-1	304 stainless steel housing without mounting brackets
ZS-300-5	316L stainless steel housing with mounting brackets

Accessories

ZS-300-BK	Mounting bracket set
ZS-300-C1	1/2" shaft adaptor (standard with housing)
ZS-300-C2	3/4" shaft adaptor
ZS-300-C3	1" shaft adaptor

Technical Data	ZS-300 (-1) (-5)
Material	All stainless steel housing, door, (with microcellular urethane gasket), shaft, coupling, universal mounting plate, and hardware.
Conduit holes	Field drilled as required. UL listed electrical fittings for NEMA 4X conditions must be used.
Drive shaft/coupler	1/2" by 5 15/16" long stainless steel with integral coupling for direct mounting to 1/2" round or hexagonal drive shafts. Square head set screws are stainless steel.
Rotating shaft seal	6061 aluminium hub with black anodize plating, bronze oilite bearings, 10 PSI, Nitrile, bi-rotational, hydrodynamic, radial lip Wave seal.
Industry standards	The Belimo ZS-300 NEMA 4X enclosure and Belimo model AMB, GMB, LF, NFB(X), AF, and AFB(X) are UL listed. These enclosures conform to the NEMA standard for Type 4X (water-tight, dust-tight and corrosion resistant).
Weight	11 lbs. [5 kg] without actuator or mounting brackets.

Dimensions (Inches [mm])

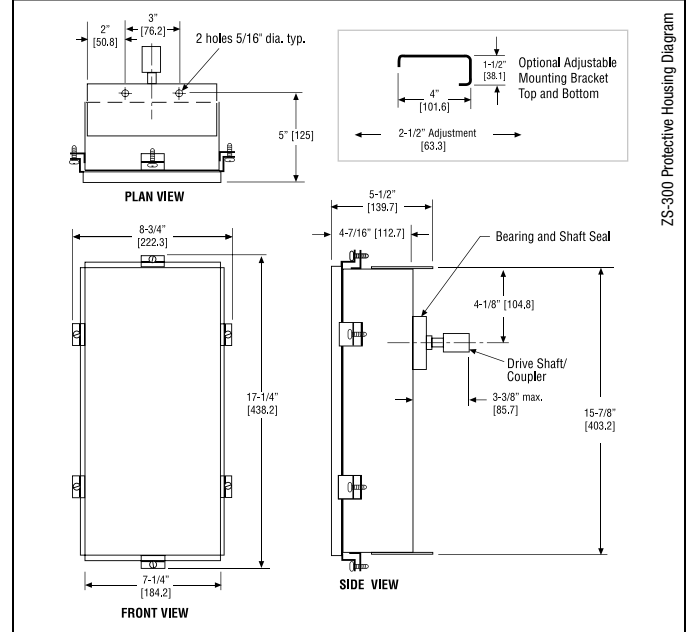

M40024 - 05/10 - Subject to change. © Belimo Aircontrols (USA), Inc.

ZS-300 (-1, -5)

NEMA 4X, stainless steel, corrosion resistant enclosures for AM, GM, NFB, NFX, AFB, AFX and AF actuators



ZS-300 Mounting Instructions

1. The damper operating shaft should extend approximately 1-1/2 inches from the damper assembly or duct side. Mount the drive shaft/coupler (1) to the damper operating shaft (2). Fasten the coupler to the damper operating shaft by tightening the two 3/8 inch square head set screws (3).
2. Determine the housing mounting orientation for the application.
3. Locate the housing hole position(s) for the control wiring of the actuator.
4. Make the necessary holes in the housing for the electrical fittings. All fittings must be rated for use in NEMA 4X applications.
5. Install (if ordered with) the 2 mounting brackets (4) to the housing using the four 1/4-20 screws, washers, and nuts (5). Do not tighten.
6. Carefully slide the housing over the drive shaft.
7. Place the housing in the desired mounting position. Transfer the mounting hole locations from the mounting bracket to the mounting surface.
8. Drill the 4 holes and fasten the brackets to the surface.
9. Install the anti-rotation strap to the housing in the correct location for the actuator which is being used.
10. Mount the actuator to the drive shaft using the instructions for the actuator being used. Finger tighten the nuts of the universal clamp. Make sure the back of the actuator is parallel to the back of the housing.
11. The operating shaft must pass through the mounting clamp at least 3/8 of an inch. It must not extend beyond the front of the housing. Slide the actuator/housing assembly in the mounting brackets to obtain the proper position.
12. Tighten the mounting brackets to the housing. Verify that the back of the actuator is still parallel to the back of the housing. Tighten the nuts on the universal clamp.
13. Make all of the required electrical connections.
14. Test the actuator/damper operation.
15. Fasten the housing cover (6) using the 6 swivel clamps.

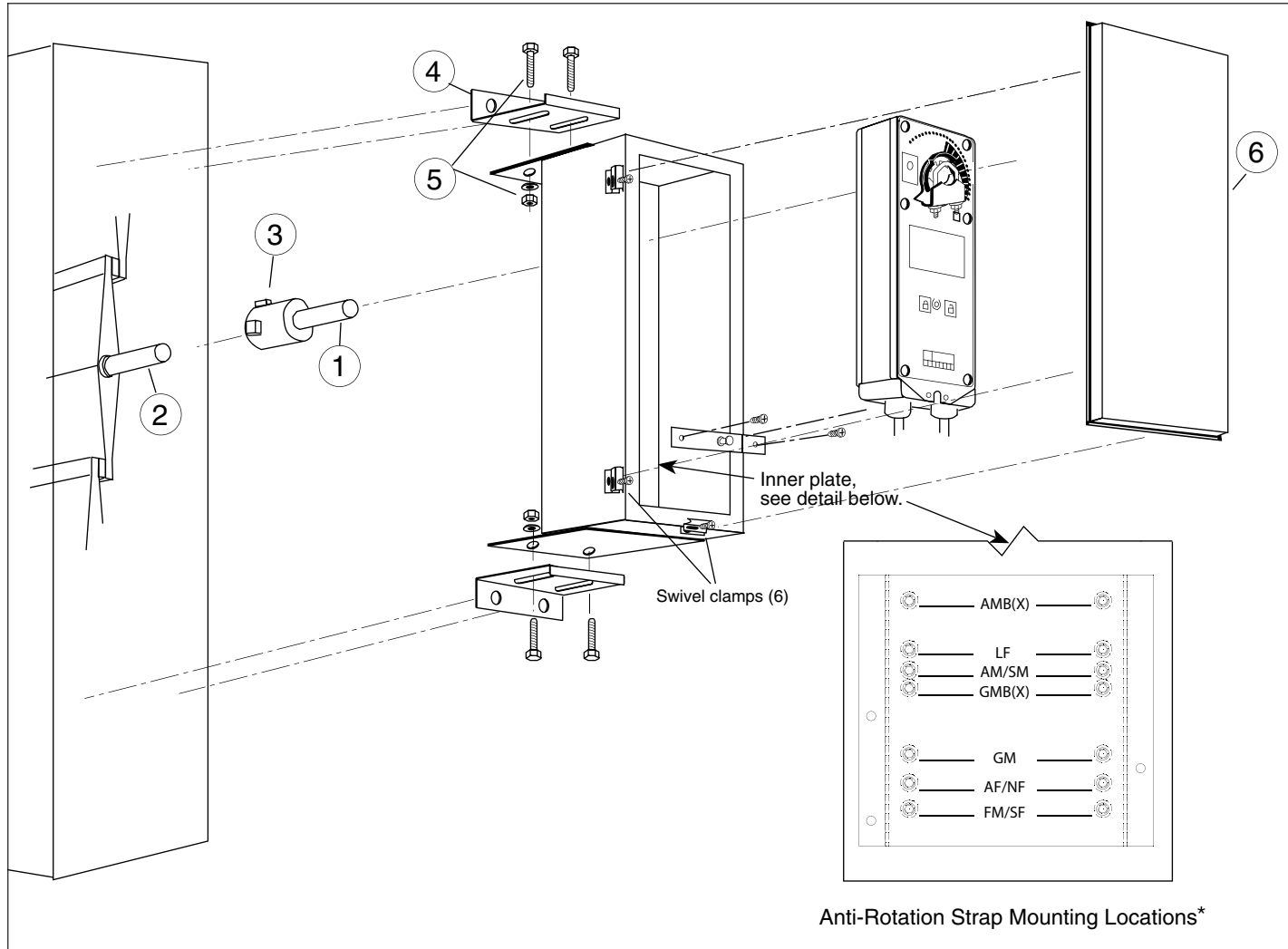

*AFB, AFX, NFB and NFX can be installed using GM mounting location without the need of the Z-AF retrofit bracket.

M40024 - 05/10 - Subject to change. © Belimo Aircontrols (USA), Inc.