

# FSLF120-FC US

On/Off, Spring Return, 350°F [177°C] for half hour, 120VAC, 15 Seconds Cycle Time



## Technical Data

|   |  |
|---|--|
| Power Supply                            | 120 VAC, ±10%, 50/60 Hz  |
| Power consumption in operation          | 18 VA  |
| Power consumption in rest position      | 4 W, 5.5 VA (50 Hz 8 VA), End stop 27 VA, 0.25 A slow blow fuse *  |
| Shaft Diameter                          | 3/8" to 1/2" round, centers on 1/2"  |
| Electrical Connection                   | 3 ft [1 m], 18 GA appliance cable with 1/2" conduit connector  |
| Overload Protection                     | electronic throughout 0° to 95° rotation   |
| Electrical Protection                   | grounded enclosure, 120V   |
| Angle of rotation                       | 95°  |
| Torque motor                            | 30 in-lb [3.5 Nm] from 32...350°F [0...177°C]  |
| direction of rotation motor             | reversible with CW/CCW mounting  |
| direction of rotation spring-return     | reversible with CW/CCW mounting  |
| Position indication                     | visual indicator, 0° to 95° (0° is full spring return position)  |
| Running time motor                      | <15 sec at rated voltage and torque<br>32...122°F [0...50°C]   |
| Running time emergency control position | <15 sec  |
| Ambient humidity                        | 5 to 95% RH non-condensing   |
| Ambient temperature                     | 32...122°F [0...50°C]  |
| Non-operating temperature               | -40...176°F [-40...80°C]   |
| Degree of Protection                    | IP30, NEMA 1   |
| Housing material                        | zinc coated steel  |
| Agency Listing                          | cULus acc. to UL60730-1A/-2-14, CAN/CSA E60730-1:02, Listed to UL 2043 - suitable for use in air plenums per Section 300.22(C) of the NEC and Section 602 of the IMC.<br>NYC Department of Buildings MEA 197-07-M<br>California State Fire Marshal Listing 3210-1593:102 |
| Noise Level (Fail-Safe)                 | 45 dB (A) motor, 62 dB (A) spring, inaudible holding   |
| Maintenance                             | maintenance free   |
| Quality Standard                        | ISO 9001   |
| Weight                                  | 4.04 lb [1.8 kg]   |

† UL File XAPX.E108966

## Fire & Smoke damper actuator

### Application

The type FSLF spring-return actuator is intended for the operation of smoke and combination fire and smoke dampers in ventilation and air-conditioning systems. The actuator will meet requirements of UL555 and UL555S when tested as an assembly with the damper and will meet requirements of UBC for 15 second opening and closing. Square footage of damper operated will depend on make and model and the temperature required.

IMPORTANT 24VDC NOTE: The FSLF24 & -S models will not operate below 24VDC. A filtered and regulated power supply must be used.

### Operation

Mounting of the actuator to the damper axle shaft or jackshaft is via a cold-weld clamp. Teeth in the clamp and V-bolt dig into the metal of both solid and hollow shafts maintaining a perfect connection. The specially designed clamp will not crush hollow shafts. The bottom end of the actuator is held by an anti-rotation strap or by a stud provided by the damper manufacturer.

The actuator is mounted in its fail safe position with the damper blade(s) closed. Upon applying power, the actuator drives the damper to the open position. The internal spring is tensioned at the same time. If the power supply is interrupted, the spring moves the damper back to its fail-safe position.

### Dimensions (Inches[mm])

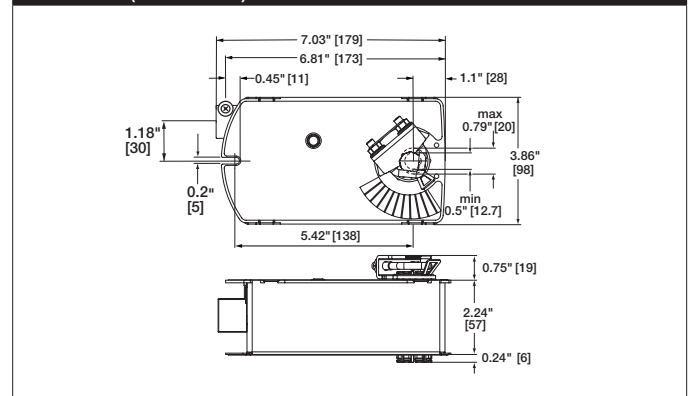

### Safety Notes

\* Neither UL nor Belimo require individual fusing of FSLF actuators.

The FSLF draws higher peak current when driving against its end stop or any other type of stop. Given the technology of fuses & breakers, this requires the value of fuse or breaker to be increased to avoid nuisance opening or tripping. A 1 amp slow blow should be used for 24VAC. A 0.25 amp slow blow should be used for 120VAC. A .125 amp slow blow should be used for 230V.

#### SAFETY NOTES

Wiring and installation must comply with all local electrical and mechanical codes.

The actuator contains no components which the user can replace or repair. Cables are not plenum rated and require flex conduit.

1/2" Threaded Connector: Screw a conduit fitting into the actuator's metal bushing. Jacket the actuator's input wiring with suitable flexible conduit. Properly terminate the conduit in a suitable junction box.

3/8" Flex Connector (-FC models): Mount the flexible conduit into the actuator's metal bushing by means of the provided screw with a torque of 1.2 Nm. Jacket the actuator's input wiring with suitable flexible conduit. Properly terminate the conduit in a suitable junction box.

| Accessories  |  |
|--------------|--|
| ---BAE165 US | 165° F electric thermal sensor, SPST, normally closed.       |
| ---S2A-F US  | Auxiliary switch, 2x SPDT, 3A (0.5A inductive) @250 VAC max. |

**Typical Specification**

All smoke and combination fire and smoke dampers shall be provided with Belimo FSTF, FSLF, FSNF, or FSAF actuators. All substitutions must be approved before submission of bid. Damper and actuator shall have UL 555S Listing for 250°F (350°F). Actuator shall have been tested to UL 2043 per requirements of IMC 602.2 and NEC 300.22 (c). Where position indication is required -S models with auxiliary switches or damper blade switches will be provided per code requirements.

**Wiring Diagrams**
**APPLICATION NOTES**

- Provide overload protection and disconnect as required.
- Actuators may be powered in parallel. Power consumption must be observed.
- Ground present on some models.

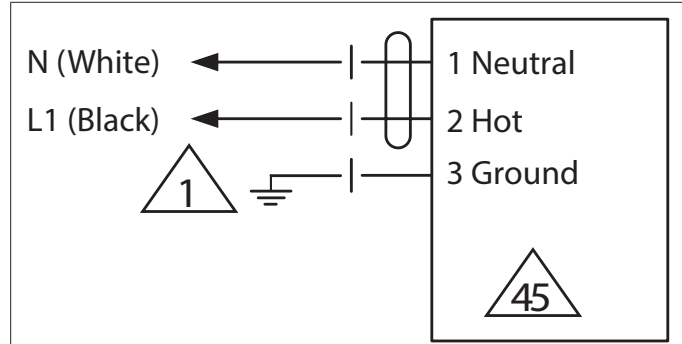
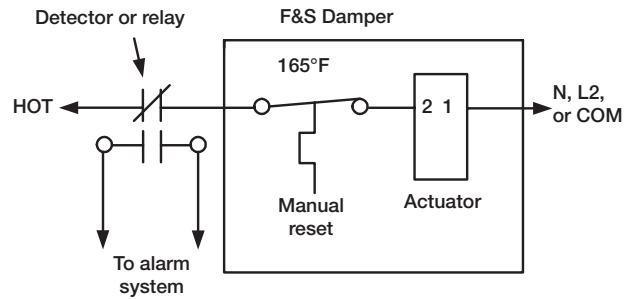
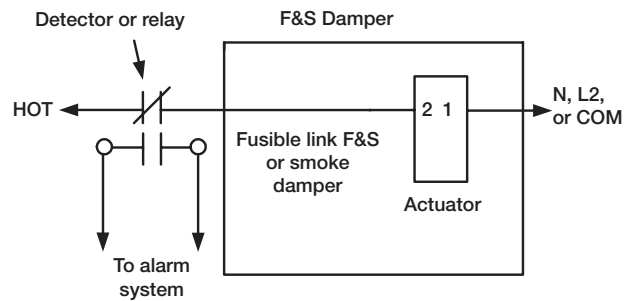
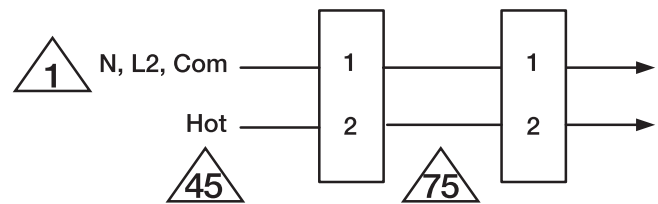
**120 VAC**

**Typical containment damper control wiring**

**Typical smoke or fusible link damper wiring**

**Parallel Actuator Wiring**

# FSLF120-S-FC US

On/Off, Spring Return, 350°F [177°C] for half hour, 120VAC, 15 Seconds Cycle Time



| Technical Data                          |  |
|---|--|
| Power Supply                            | 120 VAC, ±10%, 50/60 Hz  |
| Power consumption in operation          | 18 VA  |
| Power consumption in rest position      | 4 W, 5.5 VA (50 Hz 8 VA), End stop 27 VA, 0.25 A slow blow fuse *  |
| Shaft Diameter                          | 3/8" to 1/2" round, centers on 1/2"  |
| Electrical Connection                   | 3 ft [1 m], 18 GA appliance cable with 1/2" conduit connector  |
| Overload Protection                     | electronic throughout 0° to 95° rotation   |
| Electrical Protection                   | grounded enclosure, 120V   |
| Angle of rotation                       | 95°  |
| Torque motor                            | 30 in-lb [3.5 Nm] from 32...350°F [0...177°C]  |
| direction of rotation motor             | reversible with CW/CCW mounting  |
| direction of rotation spring-return     | reversible with CW/CCW mounting  |
| Position indication                     | visual indicator, 0° to 95° (0° is full spring return position)  |
| Running time motor                      | <15 sec at rated voltage and torque<br>32...122°F [0...50°C]   |
| Running time emergency control position | <15 sec  |
| Ambient humidity                        | 5 to 95% RH non-condensing   |
| Ambient temperature                     | 32...122°F [0...50°C]  |
| Non-operating temperature               | -40...176°F [-40...80°C]   |
| Degree of Protection                    | IP30, NEMA 1   |
| Housing material                        | zinc coated steel  |
| Agency Listing                          | cULus acc. to UL60730-1A/-2-14, CAN/CSA E60730-1:02, Listed to UL 2043 - suitable for use in air plenums per Section 300.22(C) of the NEC and Section 602 of the IMC.<br>NYC Department of Buildings MEA 197-07-M<br>California State Fire Marshal Listing 3210-1593:102 |
| Noise Level (Fail-Safe)                 | 45 dB (A) motor, 62 dB (A) spring, inaudible holding   |
| Maintenance                             | maintenance free   |
| Quality Standard                        | ISO 9001   |
| Weight                                  | 4.4 lb [2.0 kg]  |
| Auxiliary switch                        | 2 x SPST, 3A resistive (0.5A inductive) @ 250 VAC, one set at 10°, one set at 85°  |

† UL File XAPX.E108966

## Fire & Smoke damper actuator

### Application

The type FSLF spring-return actuator is intended for the operation of smoke and combination fire and smoke dampers in ventilation and air-conditioning systems. The actuator will meet requirements of UL555 and UL555S when tested as an assembly with the damper and will meet requirements of UBC for 15 second opening and closing. Square footage of damper operated will depend on make and model and the temperature required.

IMPORTANT 24VDC NOTE: The FSLF24 & -S models will not operate below 24VDC. A filtered and regulated power supply must be used.

### Operation

Mounting of the actuator to the damper axle shaft or jackshaft is via a cold-weld clamp. Teeth in the clamp and V-bolt dig into the metal of both solid and hollow shafts maintaining a perfect connection. The specially designed clamp will not crush hollow shafts. The bottom end of the actuator is held by an anti-rotation strap or by a stud provided by the damper manufacturer.

The actuator is mounted in its fail safe position with the damper blade(s) closed. Upon applying power, the actuator drives the damper to the open position. The internal spring is tensioned at the same time. If the power supply is interrupted, the spring moves the damper back to its fail-safe position.

### Dimensions (Inches[mm])

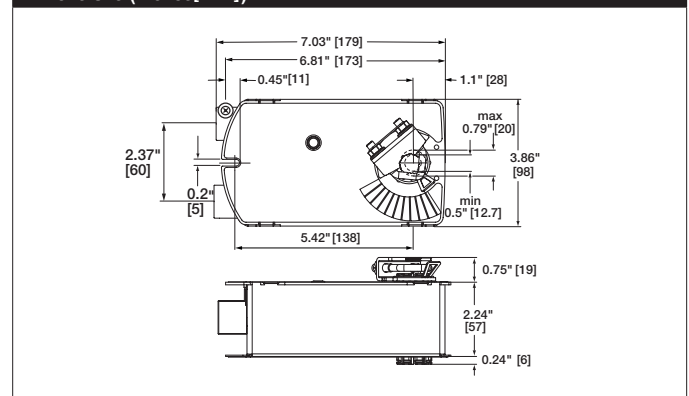

### Safety Notes

\* Neither UL nor Belimo require individual fusing of FSLF actuators.

The FSLF draws higher peak current when driving against its end stop or any other type of stop. Given the technology of fuses & breakers, this requires the value of fuse or breaker to be increased to avoid nuisance opening or tripping. A 1 amp slow blow should be used for 24VAC. A 0.25 amp slow blow should be used for 120VAC. A .125 amp slow blow should be used for 230V.

#### SAFETY NOTES

Wiring and installation must comply with all local electrical and mechanical codes.

The actuator contains no components which the user can replace or repair. Cables are not plenum rated and require flex conduit.

1/2" Threaded Connector: Screw a conduit fitting into the actuator's metal bushing. Jacket the actuator's input wiring with suitable flexible conduit. Properly terminate the conduit in a suitable junction box.

3/8" Flex Connector (-FC models): Mount the flexible conduit into the actuator's metal bushing by means of the provided screw with a torque of 1.2 Nm. Jacket the actuator's input wiring with suitable flexible conduit. Properly terminate the conduit in a suitable junction box.

| Accessories  |  |
|--------------|--|
| ---BAE165 US | 165° F electric thermal sensor, SPST, normally closed.       |
| ---S2A-F US  | Auxiliary switch, 2x SPDT, 3A (0.5A inductive) @250 VAC max. |

**Typical Specification**

All smoke and combination fire and smoke dampers shall be provided with Belimo FSTF, FSLF, FSNF, or FSAF actuators. All substitutions must be approved before submission of bid. Damper and actuator shall have UL 555S Listing for 250°F (350°F). Actuator shall have been tested to UL 2043 per requirements of IMC 602.2 and NEC 300.22 (c). Where position indication is required -S models with auxiliary switches or damper blade switches will be provided per code requirements.

**Wiring Diagrams**
**APPLICATION NOTES**

- Provide overload protection and disconnect as required.
- Actuators may be powered in parallel. Power consumption must be observed.
- S4 makes to S6 when actuator is powered open.
- Auxiliary switches are for end position indication or interlock control.
- Double insulated.
- Ground present on some models.

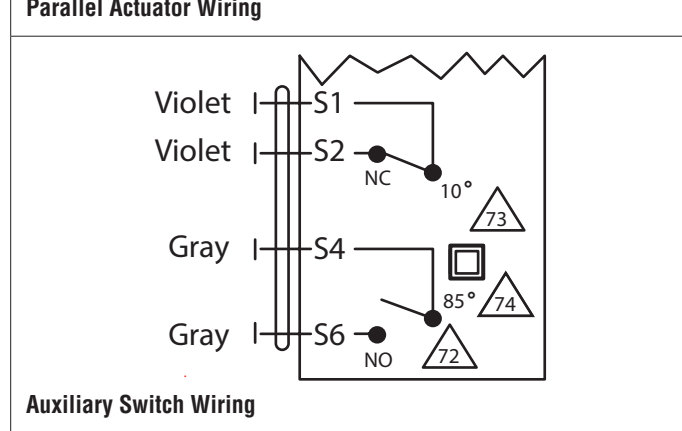
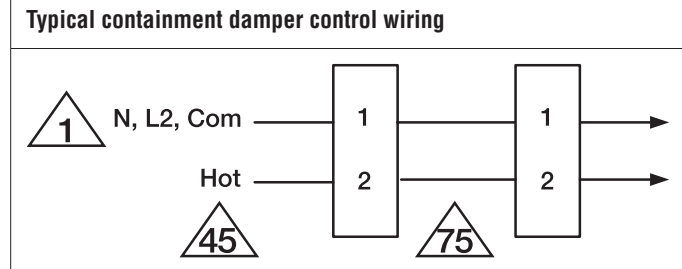
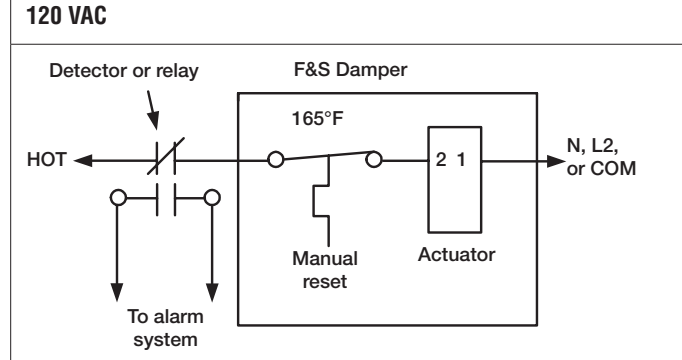
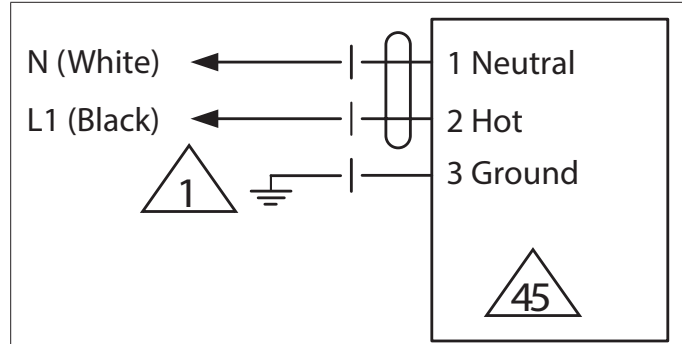

# FSLF24-FC US

On/Off, Spring Return, Fail-Safe, 24VAC/DC



| Technical Data                          |  |
|---|--|
| Power Supply                            | 24 VAC, ±10%, 50/60 Hz, 24 VDC, -0% / +50%   |
| Power consumption in operation          | 15 VA  |
| Power consumption in rest position      | 2.5 W, 3.5 VA, End stop 25 VA, 1 A slow blow fuse *  |
| Transformer sizing                      | 24 VA (class 2 power source)   |
| Shaft Diameter                          | 3/8" to 1/2" round, centers on 1/2"  |
| Electrical Connection                   | 3 ft [1 m], 18 GA, 2 color coded leads   |
| Overload Protection                     | electronic throughout 0° to 95° rotation   |
| Electrical Protection                   | actuators are double insulated   |
| Angle of rotation                       | 95°  |
| Torque motor                            | 30 in-lb [3.5 Nm] from 32...350°F [0...177°C]  |
| direction of rotation motor             | reversible with CW/CCW mounting  |
| direction of rotation spring-return     | reversible with CW/CCW mounting  |
| Position indication                     | visual indicator, 0° to 95° (0° is full spring return position)  |
| Running time motor                      | <15 sec at rated voltage and torque<br>32...122°F [0...50°C]   |
| Running time emergency control position | <15 sec  |
| Ambient humidity                        | 5 to 95% RH non-condensing   |
| Ambient temperature                     | 32...122°F [0...50°C]  |
| Non-operating temperature               | -40...176°F [-40...80°C]   |
| Degree of Protection                    | IP30, NEMA 1   |
| Housing material                        | zinc coated steel  |
| Agency Listing                          | cULus acc. to UL60730-1A/-2-14, CAN/CSA E60730-1:02, Listed to UL 2043 - suitable for use in air plenums per Section 300.22(C) of the NEC and Section 602 of the IMC.<br>NYC Department of Buildings MEA 197-07-M<br>California State Fire Marshal Listing 3210-1593:102 |
| Noise Level (Fail-Safe)                 | 45 dB (A) motor, 62 dB (A) spring, inaudible holding   |
| Maintenance                             | maintenance free   |
| Quality Standard                        | ISO 9001   |
| Weight                                  | 3.38 lb [1.7 kg]   |

† UL File XAPX.E108966

## Fire & Smoke damper actuator

### Application

The type FSLF spring-return actuator is intended for the operation of smoke and combination fire and smoke dampers in ventilation and air-conditioning systems. The actuator will meet requirements of UL555 and UL555S when tested as an assembly with the damper and will meet requirements of UBC for 15 second opening and closing. Square footage of damper operated will depend on make and model and the temperature required.

**IMPORTANT 24VDC NOTE:** The FSLF24 & -S models will not operate below 24VDC. A filtered and regulated power supply must be used.

### Operation

Mounting of the actuator to the damper axle shaft or jackshaft is via a cold-weld clamp. Teeth in the clamp and V-bolt dig into the metal of both solid and hollow shafts maintaining a perfect connection. The specially designed clamp will not crush hollow shafts. The bottom end of the actuator is held by an anti-rotation strap or by a stud provided by the damper manufacturer.

The actuator is mounted in its fail safe position with the damper blade(s) closed. Upon applying power, the actuator drives the damper to the open position. The internal spring is tensioned at the same time. If the power supply is interrupted, the spring moves the damper back to its fail-safe position.

### Dimensions (Inches[mm])

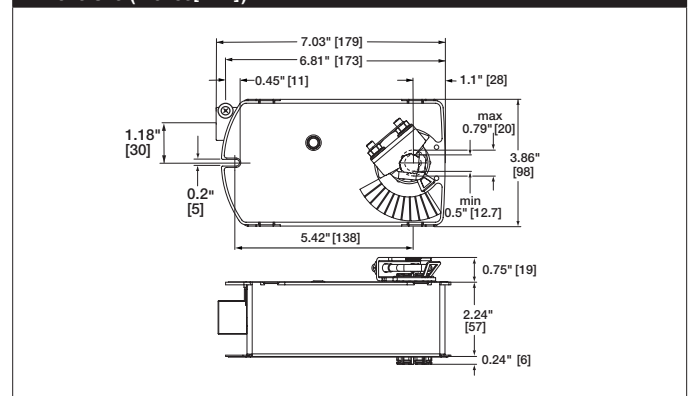

### Safety Notes

\* Neither UL nor Belimo require individual fusing of FSLF actuators.

The FSLF draws higher peak current when driving against its end stop or any other type of stop. Given the technology of fuses & breakers, this requires the value of fuse or breaker to be increased to avoid nuisance opening or tripping. A 1 amp slow blow should be used for 24VAC. A 0.25 amp slow blow should be used for 120VAC. A .125 amp slow blow should be used for 230V.

#### SAFETY NOTES

Wiring and installation must comply with all local electrical and mechanical codes.

The actuator contains no components which the user can replace or repair. Cables are not plenum rated and require flex conduit.

1/2" Threaded Connector: Screw a conduit fitting into the actuator's metal bushing. Jacket the actuator's input wiring with suitable flexible conduit.

Properly terminate the conduit in a suitable junction box.

3/8" Flex Connector (-FC models): Mount the flexible conduit into the actuator's metal bushing by means of the provided screw with a torque of 1.2 Nm. Jacket the actuator's input wiring with suitable flexible conduit. Properly terminate the conduit in a suitable junction box.

| Accessories  |  |
|--------------|--|
| ---BAE165 US | 165° F electric thermal sensor, SPST, normally closed.       |
| ---S2A-F US  | Auxiliary switch, 2x SPDT, 3A (0.5A inductive) @250 VAC max. |

**Typical Specification**

All smoke and combination fire and smoke dampers shall be provided with Belimo FSTF, FSLF, FSNF, or FSAF actuators. All substitutions must be approved before submission of bid. Damper and actuator shall have UL 555S Listing for 250°F (350°F). Actuator shall have been tested to UL 2043 per requirements of IMC 602.2 and NEC 300.22 (c). Where position indication is required -S models with auxiliary switches or damper blade switches will be provided per code requirements.

**Wiring Diagrams**

**APPLICATION NOTES**

- Provide overload protection and disconnect as required.
- Actuators may be powered in parallel. Power consumption must be observed.
- Ground present on some models.

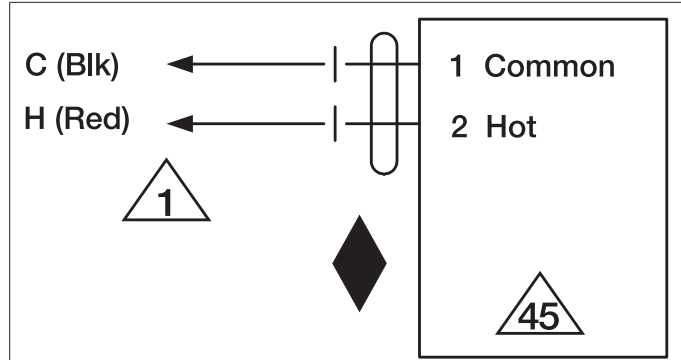

24 VAC

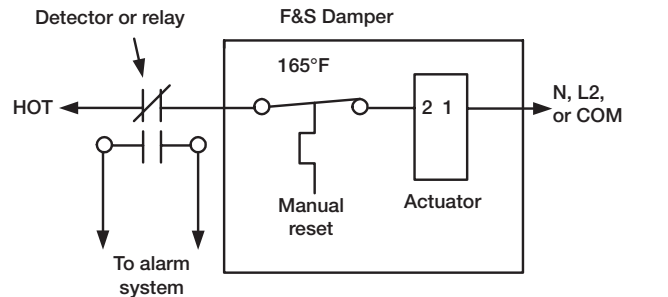

Typical containment damper control wiring

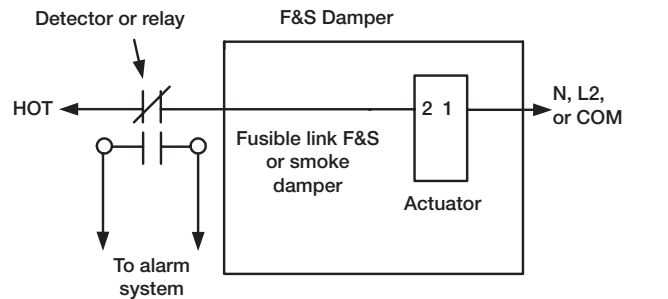

Typical smoke or fusible link damper wiring

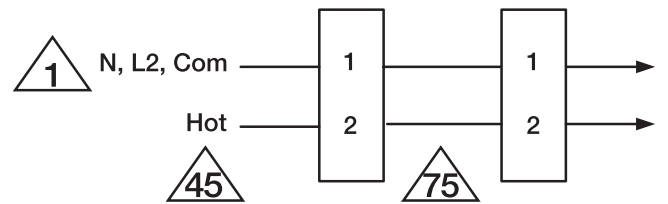

Parallel Actuator Wiring

# FSLF24-S-FC US

On/Off, Spring Return, 350°F for a Half Hour, 15 Seconds Cycle Time



## Technical Data

|   |  |
|---|--|
| Power Supply                            | 24 VAC, ±10%, 50/60 Hz, 24 VDC, -0% / +50%   |
| Power consumption in operation          | 15 VA  |
| Power consumption in rest position      | 2.5 W, 3.5 VA, End stop 25 VA, 1 A slow blow fuse *  |
| Transformer sizing                      | 24 VA (class 2 power source)   |
| Shaft Diameter                          | 3/8" to 1/2" round, centers on 1/2"  |
| Electrical Connection                   | 3 ft [1 m], 18 GA, 2 color coded leads   |
| Overload Protection                     | electronic throughout 0° to 95° rotation   |
| Electrical Protection                   | actuators are double insulated   |
| Angle of rotation                       | 95°  |
| Torque motor                            | 30 in-lb [3.5 Nm] from 32...350°F [0...177°C]  |
| direction of rotation motor             | reversible with CW/CCW mounting  |
| direction of rotation spring-return     | reversible with CW/CCW mounting  |
| Position indication                     | visual indicator, 0° to 95° (0° is full spring return position)  |
| Running time motor                      | <15 sec at rated voltage and torque<br>32...122°F [0...50°C]   |
| Running time emergency control position | <15 sec  |
| Ambient humidity                        | 5 to 95% RH non-condensing   |
| Ambient temperature                     | 32...122°F [0...50°C]  |
| Non-operating temperature               | -40...176°F [-40...80°C]   |
| Degree of Protection                    | IP30, NEMA 1   |
| Housing material                        | zinc coated steel  |
| Agency Listing                          | cULus acc. to UL60730-1A/-2-14, CAN/CSA E60730-1:02, Listed to UL 2043 - suitable for use in air plenums per Section 300.22(C) of the NEC and Section 602 of the IMC.<br>NYC Department of Buildings MEA 197-07-M<br>California State Fire Marshal Listing 3210-1593:102 |
| Noise Level (Fail-Safe)                 | 45 dB (A) motor, 62 dB (A) spring, inaudible holding   |
| Maintenance                             | maintenance free   |
| Quality Standard                        | ISO 9001   |
| Weight                                  | 4.2 lb [1.9 kg]  |
| Auxiliary switch                        | 2 x SPST, 3A resistive (0.5A inductive) @ 250 VAC, one set at 10°, one set at 85°  |

† UL File XAPX.E108966

## Fire & Smoke damper actuator

### Application

The type FSLF spring-return actuator is intended for the operation of smoke and combination fire and smoke dampers in ventilation and air-conditioning systems. The actuator will meet requirements of UL555 and UL555S when tested as an assembly with the damper and will meet requirements of UBC for 15 second opening and closing. Square footage of damper operated will depend on make and model and the temperature required.

**IMPORTANT 24VDC NOTE:** The FSLF24 & -S models will not operate below 24VDC. A filtered and regulated power supply must be used.

### Operation

Mounting of the actuator to the damper axle shaft or jackshaft is via a cold-weld clamp. Teeth in the clamp and V-bolt dig into the metal of both solid and hollow shafts maintaining a perfect connection. The specially designed clamp will not crush hollow shafts. The bottom end of the actuator is held by an anti-rotation strap or by a stud provided by the damper manufacturer.

The actuator is mounted in its fail safe position with the damper blade(s) closed. Upon applying power, the actuator drives the damper to the open position. The internal spring is tensioned at the same time. If the power supply is interrupted, the spring moves the damper back to its fail-safe position.

### Dimensions (Inches[mm])

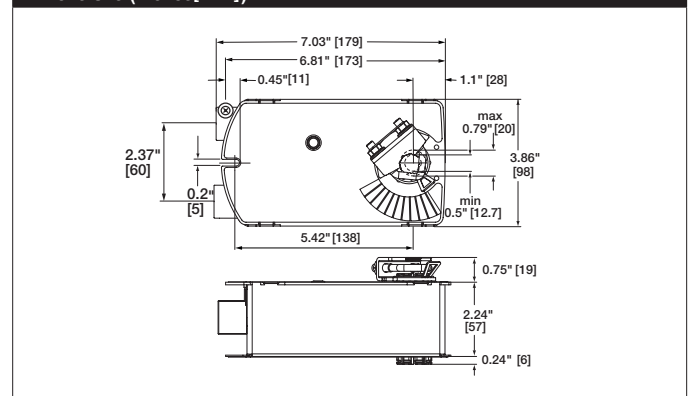

### Safety Notes

\* Neither UL nor Belimo require individual fusing of FSLF actuators.

The FSLF draws higher peak current when driving against its end stop or any other type of stop. Given the technology of fuses & breakers, this requires the value of fuse or breaker to be increased to avoid nuisance opening or tripping. A 1 amp slow blow should be used for 24VAC. A 0.25 amp slow blow should be used for 120VAC. A .125 amp slow blow should be used for 230V.

#### SAFETY NOTES

Wiring and installation must comply with all local electrical and mechanical codes.

The actuator contains no components which the user can replace or repair. Cables are not plenum rated and require flex conduit.

1/2" Threaded Connector: Screw a conduit fitting into the actuator's metal bushing. Jacket the actuator's input wiring with suitable flexible conduit.

Properly terminate the conduit in a suitable junction box.

3/8" Flex Connector (-FC models): Mount the flexible conduit into the actuator's metal bushing by means of the provided screw with a torque of 1.2 Nm. Jacket the actuator's input wiring with suitable flexible conduit. Properly terminate the conduit in a suitable junction box.

| Accessories  |  |
|--------------|--|
| ---BAE165 US | 165° F electric thermal sensor, SPST, normally closed.       |
| ---S2A-F US  | Auxiliary switch, 2x SPDT, 3A (0.5A inductive) @250 VAC max. |

**Typical Specification**

All smoke and combination fire and smoke dampers shall be provided with Belimo FSTF, FSLF, FSNF, or FSAF actuators. All substitutions must be approved before submission of bid. Damper and actuator shall have UL 555S Listing for 250°F (350°F). Actuator shall have been tested to UL 2043 per requirements of IMC 602.2 and NEC 300.22 (c). Where position indication is required -S models with auxiliary switches or damper blade switches will be provided per code requirements.

**Wiring Diagrams**
**APPLICATION NOTES**

- Provide overload protection and disconnect as required.
- Actuators may be powered in parallel. Power consumption must be observed.
- S4 makes to S6 when actuator is powered open.
- Auxiliary switches are for end position indication or interlock control.
- Double insulated.
- Ground present on some models.

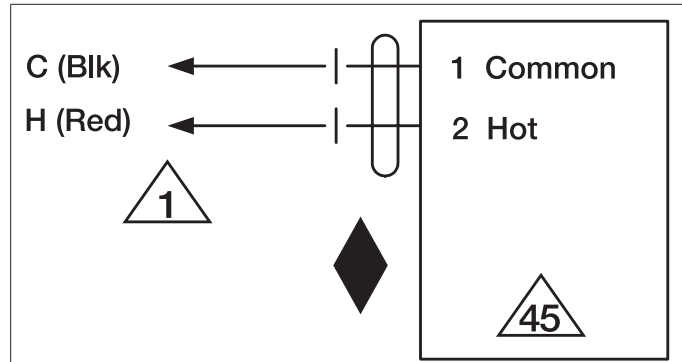
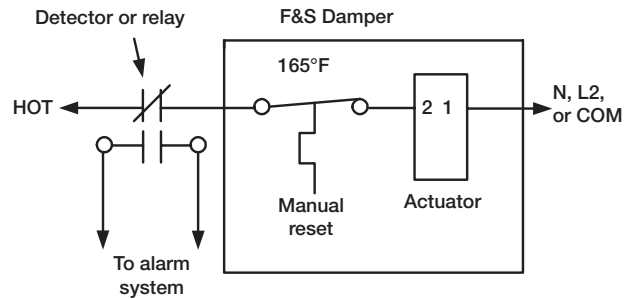
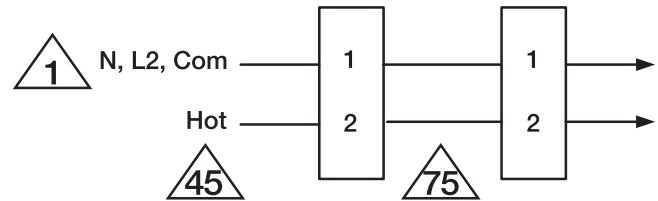
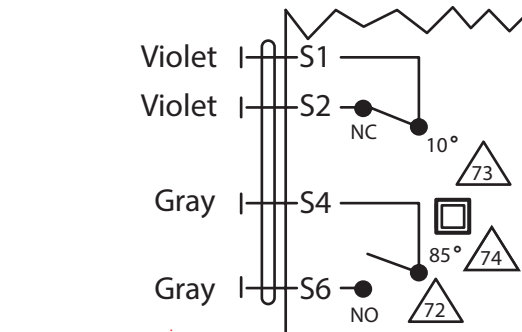
**24 VAC**

**Typical containment damper control wiring**

**Parallel Actuator Wiring**

**Auxiliary Switch Wiring**



# FSLF230 US

On/Off, Spring Return, 350°F [177°C] for a half hour, 15 Seconds Cycle Time



## Technical Data

|   |  |
|---|--|
| Power Supply                            | 230 VAC, ±10%, 50/60 Hz  |
| Power consumption in operation          | 17 VA  |
| Power consumption in rest position      | 4 W, 8 VA (60 Hz 5.5 VA), End stop 27 VA, 0.125 A slow blow fuse *   |
| Shaft Diameter                          | 3/8" to 1/2" round, centers on 1/2"  |
| Electrical Connection                   | 3 ft [1 m], 18 GA, 3 color coded leads   |
| Overload Protection                     | electronic throughout 0° to 95° rotation   |
| Electrical Protection                   | grounded enclosure, 230V   |
| Angle of rotation                       | 95°  |
| Torque motor                            | 30 in-lb [3.5 Nm] from 32...350°F [0...177°C]  |
| direction of rotation motor             | reversible with CW/CCW mounting  |
| direction of rotation spring-return     | reversible with CW/CCW mounting  |
| Position indication                     | visual indicator, 0° to 95° (0° is full spring return position)  |
| Running time motor                      | <15 sec at rated voltage and torque<br>32...122°F [0...50°C]   |
| Running time emergency control position | <15 sec  |
| Ambient humidity                        | 5 to 95% RH non-condensing   |
| Ambient temperature                     | 32...122°F [0...50°C]  |
| Non-operating temperature               | -40...176°F [-40...80°C]   |
| Degree of Protection                    | IP30, NEMA 1   |
| Housing material                        | zinc coated steel  |
| Agency Listing                          | cULus acc. to UL60730-1A/-2-14, CAN/CSA E60730-1:02, Listed to UL 2043 - suitable for use in air plenums per Section 300.22(C) of the NEC and Section 602 of the IMC.<br>NYC Department of Buildings MEA 197-07-M<br>California State Fire Marshal Listing 3210-1593:102 |
| Noise Level (Fail-Safe)                 | 45 dB (A) motor, 62 dB (A) spring, inaudible holding   |
| Maintenance                             | maintenance free   |
| Quality Standard                        | ISO 9001   |
| Weight                                  | 4.12 lb [1.8 kg]   |

† UL File XAPX.E108966

## Fire & Smoke damper actuator

### Application

The type FSLF spring-return actuator is intended for the operation of smoke and combination fire and smoke dampers in ventilation and air-conditioning systems. The actuator will meet requirements of UL555 and UL555S when tested as an assembly with the damper and will meet requirements of UBC for 15 second opening and closing. Square footage of damper operated will depend on make and model and the temperature required.

IMPORTANT 24VDC NOTE: The FSLF24 & -S models will not operate below 24VDC. A filtered and regulated power supply must be used.

### Operation

Mounting of the actuator to the damper axle shaft or jackshaft is via a cold-weld clamp. Teeth in the clamp and V-bolt dig into the metal of both solid and hollow shafts maintaining a perfect connection. The specially designed clamp will not crush hollow shafts. The bottom end of the actuator is held by an anti-rotation strap or by a stud provided by the damper manufacturer.

The actuator is mounted in its fail safe position with the damper blade(s) closed. Upon applying power, the actuator drives the damper to the open position. The internal spring is tensioned at the same time. If the power supply is interrupted, the spring moves the damper back to its fail-safe position.

## Dimensions (Inches[mm])

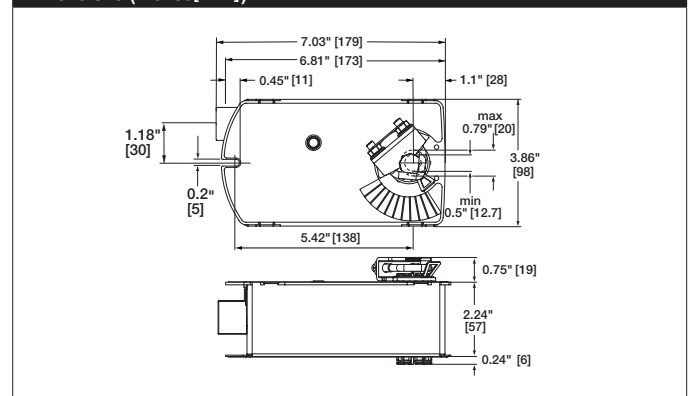

## Safety Notes

\* Neither UL nor Belimo require individual fusing of FSLF actuators.

The FSLF draws higher peak current when driving against its end stop or any other type of stop. Given the technology of fuses & breakers, this requires the value of fuse or breaker to be increased to avoid nuisance opening or tripping. A 1 amp slow blow should be used for 24VAC. A 0.25 amp slow blow should be used for 120VAC. A 1.25 amp slow blow should be used for 230V.

### SAFETY NOTES

Wiring and installation must comply with all local electrical and mechanical codes.

The actuator contains no components which the user can replace or repair. Cables are not plenum rated and require flex conduit.

1/2" Threaded Connector: Screw a conduit fitting into the actuator's metal bushing. Jacket the actuator's input wiring with suitable flexible conduit. Properly terminate the conduit in a suitable junction box.

3/8" Flex Connector (-FC models): Mount the flexible conduit into the actuator's metal bushing by means of the provided screw with a torque of 1.2 Nm. Jacket the actuator's input wiring with suitable flexible conduit. Properly terminate the conduit in a suitable junction box.

| Accessories  |  |
|--------------|--|
| ---BAE165 US | 165° F electric thermal sensor, SPST, normally closed.       |
| ---S2A-F US  | Auxiliary switch, 2x SPDT, 3A (0.5A inductive) @250 VAC max. |

### Typical Specification

All smoke and combination fire and smoke dampers shall be provided with Belimo FSTF, FSLF, FSNF, or FSAF actuators. All substitutions must be approved before submission of bid. Damper and actuator shall have UL 555S Listing for 250°F (350°F). Actuator shall have been tested to UL 2043 per requirements of IMC 602.2 and NEC 300.22 (c). Where position indication is required -S models with auxiliary switches or damper blade switches will be provided per code requirements.

### Wiring Diagrams

#### APPLICATION NOTES

- Provide overload protection and disconnect as required.
- Actuators may be powered in parallel. Power consumption must be observed.
- Ground present on some models.

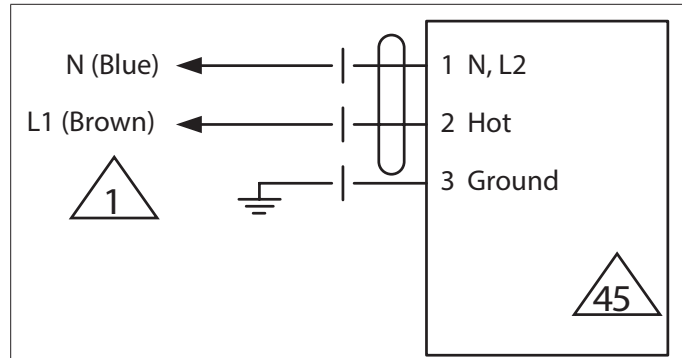

230 VAC

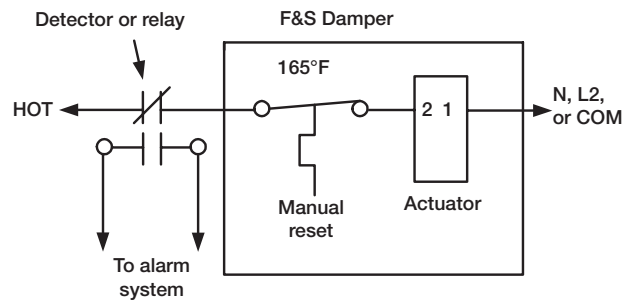

Typical containment damper control wiring

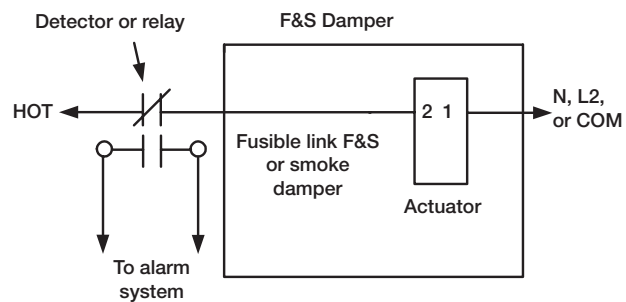

Typical smoke or fusible link damper wiring

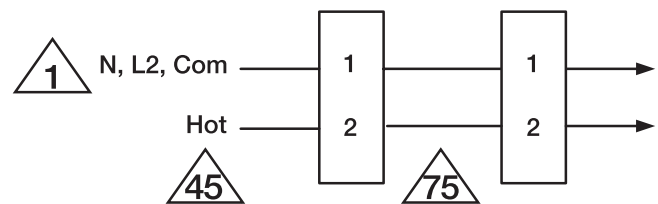

Parallel Actuator Wiring

# FSLF230-S US

On/Off, Spring Return, 350°F [177°C] for a half hour, 15 Seconds Cycle Time



| Technical Data                          |  |
|---|--|
| Power Supply                            | 230 VAC, ±10%, 50/60 Hz  |
| Power consumption in operation          | 17 VA  |
| Power consumption in rest position      | 4 W, 8 VA (60 Hz 5.5 VA), End stop 27 VA, 0.125 A slow blow fuse *   |
| Shaft Diameter                          | 3/8" to 1/2" round, centers on 1/2"  |
| Electrical Connection                   | 3 ft [1 m], 18 GA, 3 color coded leads   |
| Overload Protection                     | electronic throughout 0° to 95° rotation   |
| Electrical Protection                   | grounded enclosure, 230V   |
| Angle of rotation                       | 95°  |
| Torque motor                            | 30 in-lb [3.5 Nm] from 32...350°F [0...177°C]  |
| direction of rotation motor             | reversible with CW/CCW mounting  |
| direction of rotation spring-return     | reversible with CW/CCW mounting  |
| Position indication                     | visual indicator, 0° to 95° (0° is full spring return position)  |
| Running time motor                      | <15 sec at rated voltage and torque<br>32...122°F [0...50°C]   |
| Running time emergency control position | <15 sec  |
| Ambient humidity                        | 5 to 95% RH non-condensing   |
| Ambient temperature                     | 32...122°F [0...50°C]  |
| Non-operating temperature               | -40...176°F [-40...80°C]   |
| Degree of Protection                    | IP30, NEMA 1   |
| Housing material                        | zinc coated steel  |
| Agency Listing                          | cULus acc. to UL60730-1A/-2-14, CAN/CSA E60730-1:02, Listed to UL 2043 - suitable for use in air plenums per Section 300.22(C) of the NEC and Section 602 of the IMC.<br>NYC Department of Buildings MEA 197-07-M<br>California State Fire Marshal Listing 3210-1593:102 |
| Noise Level (Fail-Safe)                 | 45 dB (A) motor, 62 dB (A) spring, inaudible holding   |
| Maintenance                             | maintenance free   |
| Quality Standard                        | ISO 9001   |
| Weight                                  | 4.4 lb [2.0 kg]  |
| Auxiliary switch                        | 2 x SPST, 3A resistive (0.5A inductive) @ 250 VAC, one set at 10°, one set at 85°  |

† UL File XAPX.E108966

## Fire & Smoke damper actuator

### Application

The type FSLF spring-return actuator is intended for the operation of smoke and combination fire and smoke dampers in ventilation and air-conditioning systems. The actuator will meet requirements of UL555 and UL555S when tested as an assembly with the damper and will meet requirements of UBC for 15 second opening and closing. Square footage of damper operated will depend on make and model and the temperature required.

**IMPORTANT 24VDC NOTE:** The FSLF24 & -S models will not operate below 24VDC. A filtered and regulated power supply must be used.

### Operation

Mounting of the actuator to the damper axle shaft or jackshaft is via a cold-weld clamp. Teeth in the clamp and V-bolt dig into the metal of both solid and hollow shafts maintaining a perfect connection. The specially designed clamp will not crush hollow shafts. The bottom end of the actuator is held by an anti-rotation strap or by a stud provided by the damper manufacturer.

The actuator is mounted in its fail safe position with the damper blade(s) closed. Upon applying power, the actuator drives the damper to the open position. The internal spring is tensioned at the same time. If the power supply is interrupted, the spring moves the damper back to its fail-safe position.

### Dimensions (Inches[mm])

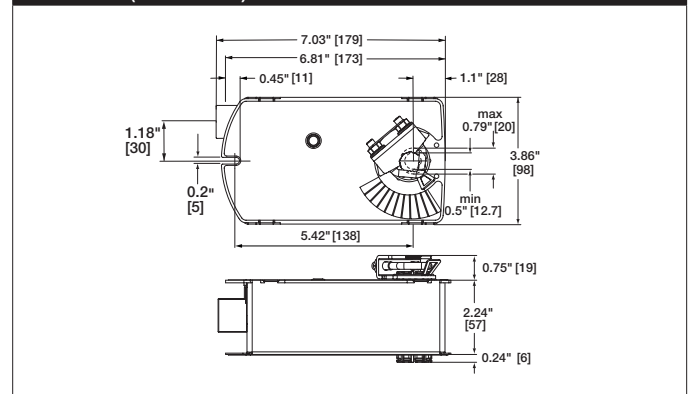

### Safety Notes

\* Neither UL nor Belimo require individual fusing of FSLF actuators.

The FSLF draws higher peak current when driving against its end stop or any other type of stop. Given the technology of fuses & breakers, this requires the value of fuse or breaker to be increased to avoid nuisance opening or tripping. A 1 amp slow blow should be used for 24VAC. A 0.25 amp slow blow should be used for 120VAC. A 1.25 amp slow blow should be used for 230V.

#### SAFETY NOTES

Wiring and installation must comply with all local electrical and mechanical codes.

The actuator contains no components which the user can replace or repair. Cables are not plenum rated and require flex conduit.

1/2" Threaded Connector: Screw a conduit fitting into the actuator's metal bushing. Jacket the actuator's input wiring with suitable flexible conduit. Properly terminate the conduit in a suitable junction box.

3/8" Flex Connector (-FC models): Mount the flexible conduit into the actuator's metal bushing by means of the provided screw with a torque of 1.2 Nm. Jacket the actuator's input wiring with suitable flexible conduit. Properly terminate the conduit in a suitable junction box.

| Accessories  |  |
|--------------|--|
| ---BAE165 US | 165° F electric thermal sensor, SPST, normally closed.       |
| ---S2A-F US  | Auxiliary switch, 2x SPDT, 3A (0.5A inductive) @250 VAC max. |

**Typical Specification**

All smoke and combination fire and smoke dampers shall be provided with Belimo FSTF, FSLF, FSNF, or FSAF actuators. All substitutions must be approved before submission of bid. Damper and actuator shall have UL 555S Listing for 250°F (350°F). Actuator shall have been tested to UL 2043 per requirements of IMC 602.2 and NEC 300.22 (c). Where position indication is required -S models with auxiliary switches or damper blade switches will be provided per code requirements.

**Wiring Diagrams**
**APPLICATION NOTES**

- Provide overload protection and disconnect as required.
- Actuators may be powered in parallel. Power consumption must be observed.
- S4 makes to S6 when actuator is powered open.
- Auxiliary switches are for end position indication or interlock control.
- Double insulated.
- Ground present on some models.

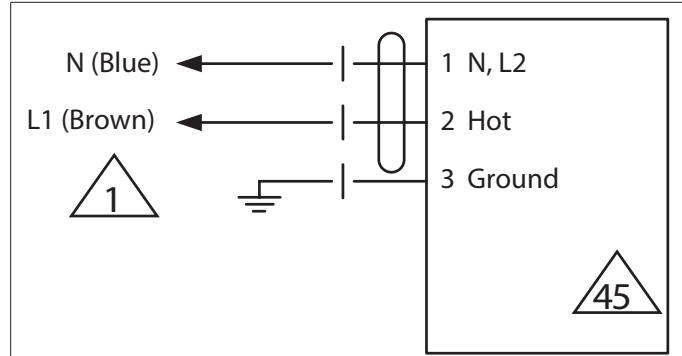
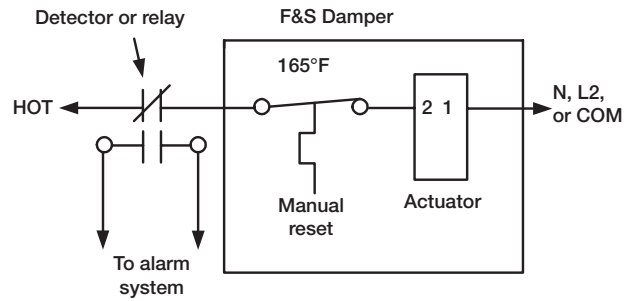
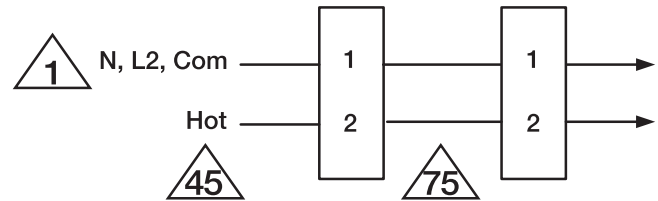
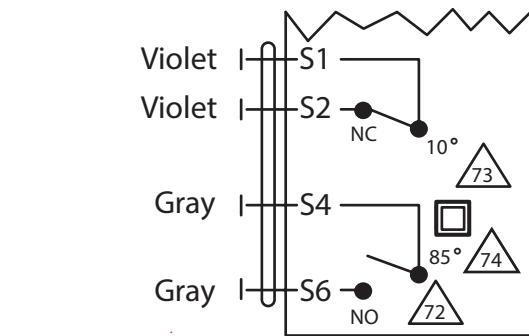
**230 VAC**

**Typical containment damper control wiring**

**Parallel Actuator Wiring**

**Auxiliary Switch Wiring**