

Application

Model HTD-621 is a heavy duty flanged frame style industrial control damper qualified for use in tunnel and transit systems. The dual skin blades have silicone blade seals that meet the demanding requirements for strength and operability to standards such as NFPA-130 and 502. The leakage of the HTD-621 is 25% of the value for UL Class I at 12 in. wg.

The design can be modified and the product can be qualified to meet the requirements of any specification.

Ratings

Velocity

Up to 4000 fpm (20.3 m/s)

Temperature

250°F (121°C) continuous;
482°F (250°C) for 2 hours (NFPA 130, 502).
Consult factory for high temperature options

Pressure

Up to 24 in. wg (6 kPa) - differential pressure

Leakage

Less than 4 cfm/ft² at 12 in. wg

Fatigue Cycles

8 million reverse cycles at 24 in. wg (6kPa)

Size Limitations

The following table provides minimum and maximum single section size. Multiple sections can be linked together to create larger damper assemblies.

Single Section Size

Minimum	12 in. W x 12 in. H (305mm x 305mm)
Maximum	60 in. W x 96 in. H (1524mm x 2438mm)

Options

- Wide range of electric and pneumatic actuators available, including high temp applications
- High temp limit switches
- Multiple panel assemblies
- Mounting holes in flanges
- Perimeter gaskets
- Rubbish screens
- Junction boxes with factory wiring

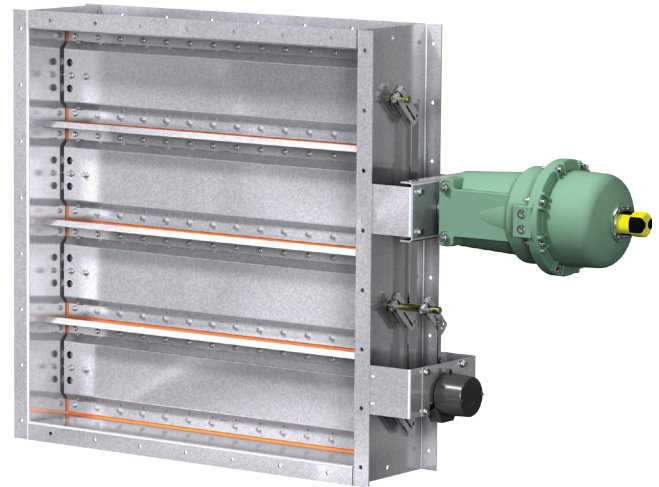

*Actual inside dimensions.

Construction

	Standard	Optional
Frame Depth	12 in. (305 mm)	8 in. (203 mm) 10 in. (254 mm)
Frame Material	Galvanized (ASTM A653)	304SS, 316SS
Frame Thickness	12 ga. (2.7 mm)	14 ga. (1.9 mm), 10 ga. (3.4 mm) 0.25 in. (6.4 mm) 0.188 in. (4.8 mm)
Flange Width	2 in. (51 mm)	1½ in. - 4 in. (38 mm - 102mm),
Blade Action	Parallel	-
Blade Deflection	L/180	L/360
Blade Material	Galvanized steel (ASTM A653)	304SS, 316SS
Blade Seals	Silicone	None
Blade Thickness	12 ga. (2.7 mm)	16 ga. (1.5mm) 14 ga. (1.9 mm) 10 ga. (3.5 mm)
Blade Type	Dual skin with perimeter seal	
Linkage	External industrial type zinc plated steel	External industrial type stainless steel
Axle Diameter	¾ in. (12.7 mm)	1 in. (25.4 mm)
Axle Bearing	Stainless steel sleeve	Oil impregnated bronze, Relubricable ball, High temperature carbon
Axle Material	Zinc plated steel	304SS, 316SS
Axle Type	Stub	Full length

Assembly

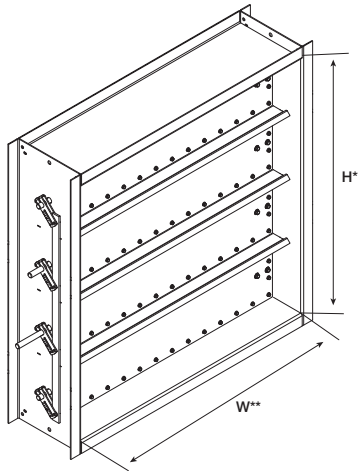

*Actual inside dimensions.

** The W dimension is ALWAYS parallel with the damper blade length.

Smoke Extraction Duct

The HTD-621 has a very low leakage rating which make it perfect for single point extraction systems. This allows for lower fan CFM to be utilized with confidence that dampers will remain low leakage over their entire life expectancy.

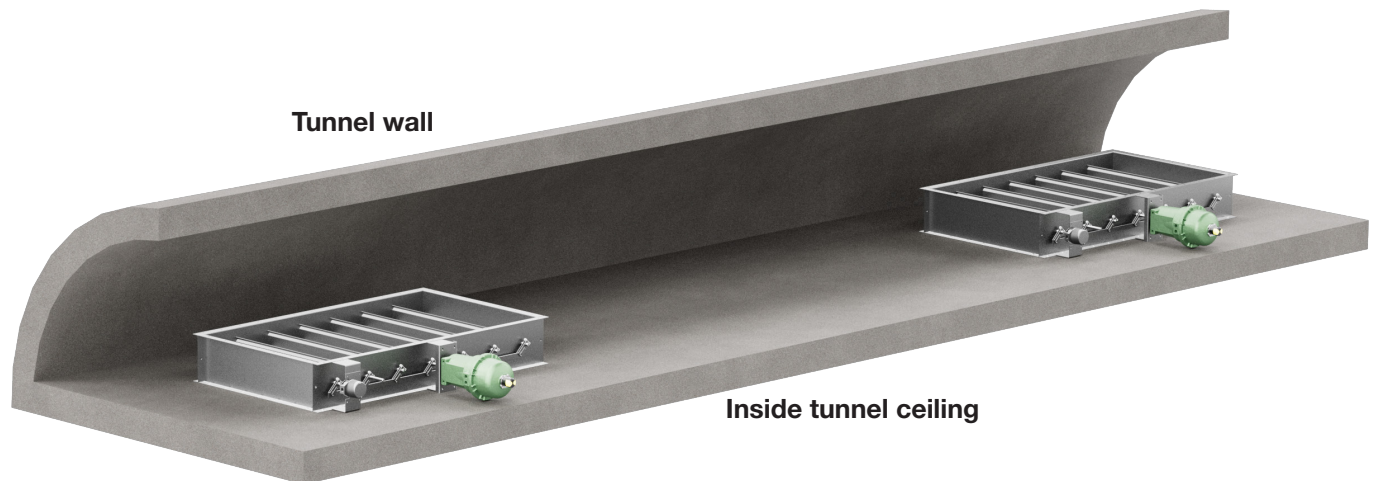

Pressure Drop and Leakage

This pressure drop data was conducted in accordance with AMCA Standard 500-D using the two configurations shown. All data has been corrected to represent standard air at a density of .075 lb./ft³ (1.2 kg/m³).

Actual pressure drop found in any HVAC system is a combination of many factors. This pressure drop information along with an analysis of other system influences should be used to estimate actual pressure losses for a damper installed in a given HVAC system.

AMCA Test Figures

Figure 5.3 Illustrates a fully ducted damper. This configuration has the lowest pressure drop of the two test configurations because entrance and exit losses are minimized by straight duct runs upstream and downstream of the damper.

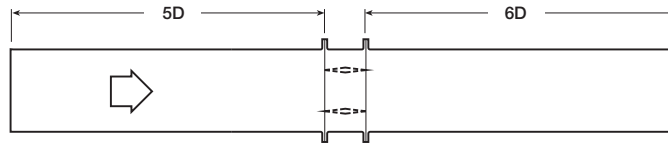

Pressure Drop (english version)
42 in. x 42 in. (1067mm x 1067mm) Damper

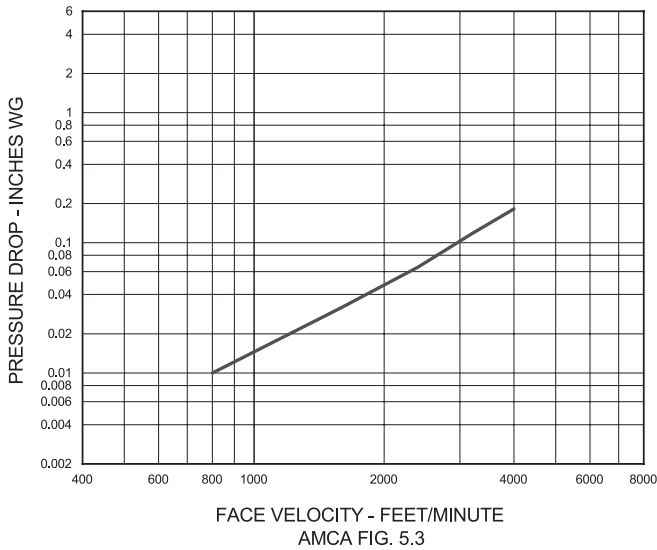

Pressure Drop (metric version)
42 in. x 42 in. (1067mm x 1067mm) Damper

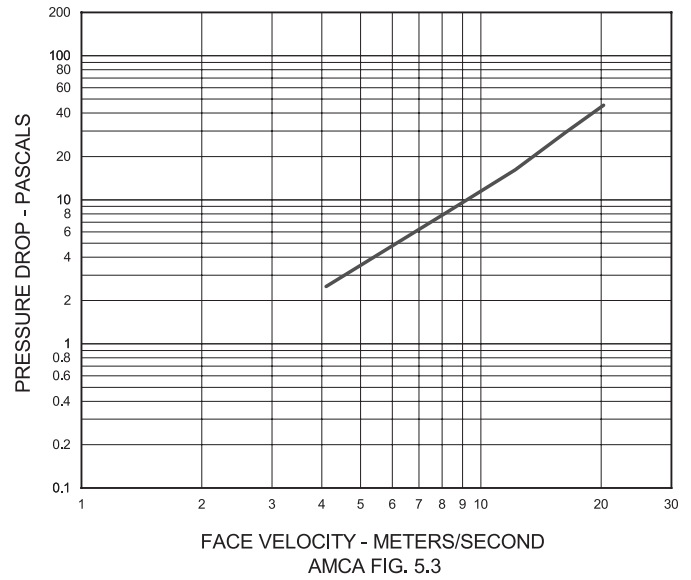

Leakage

Damper leakage (with blades fully closed) varies based on the type of low leakage seals applied. Leakage testing was conducted in accordance with AMCA Standard 500-D and is expressed as CFM per sq. ft. of damper face area. All data has been corrected to represent standard air at a density of .075 lb./ft³ (1.2 kg/m³).

Leakage (english version)
42 in. x 42 in. (1067mm x 1067mm) Damper

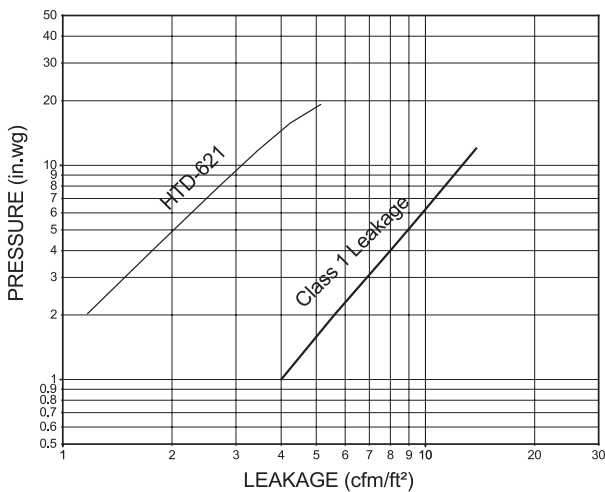

Leakage (metric version)
42 in. x 42 in. (1067mm x 1067mm) Damper

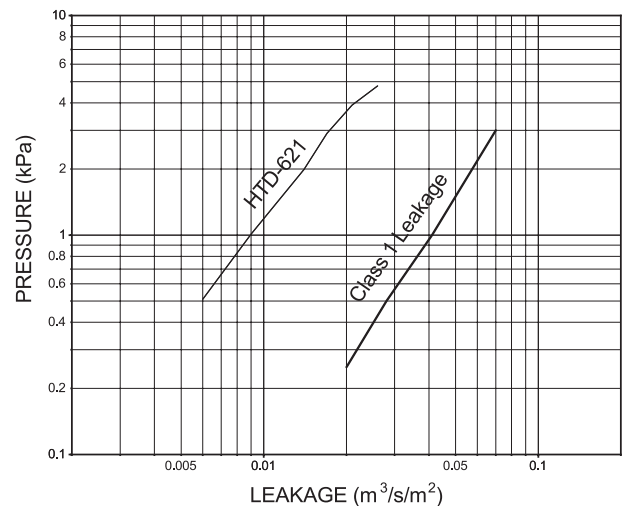



[IOM](#)



[HD DAMPER
CATALOG](#)



[TUNNEL CATALOG](#)



[DAMPER
SELECTION
GUIDE](#)



[WARRANTY](#)

Specifications

Industrial grade control dampers meeting the following specifications shall be furnished and installed where shown on plans and/or as described in schedules.

Dampers shall consist of: a 12 ga. (2.7mm) galvanized steel channel frame with 12 in. (305mm) minimum depth and 2 in. (51mm) flanges; double skin airfoil type blades fabricated from two layers of 12 ga. (2.7mm) galvanized steel; 3/4 in. (19mm) dia. plated steel axles turning in oil impregnated sintered stainless steel bearings press-fit into frame; and external (out of the airstream) blade-to-blade linkage. Blade seals shall be silicone rubber.

Damper manufacturer's printed application and performance data including pressure, velocity and temperature limitations shall be submitted for approval showing damper suitable for pressures to 24 in. wg (6 kPa), velocities to 4000 fpm (20.3 m/s) and temperatures to 482°F (250°C). Testing and ratings to be in accordance with AMCA Standard 500-D.

Dampers shall meet the requirements of NFPA-130, NFPA-502 and remain fully operational after exposure to a temperature of 482°F (250°C) for a minimum of 1 hour.

Basis of design is Greenheck model HTD-621.