



# OWNER'S GUIDE

## R-102™ RESTAURANT FIRE SUPPRESSION SYSTEM

The National Fire Protection Association (NFPA) recommends that employees be instructed in personal safety and the operation of the system. ANSUL® provides this owner's guide with each Restaurant Fire Suppression System.

This owner's guide has been provided to help you understand...

- ...how your restaurant system works
- ...your responsibilities for maintenance
- ...what to do in case of fire

This owner's guide is not intended to cover all requirements detailed in the Installation, Operation, Recharge, Inspection, and Maintenance Manual, Part No. 418087. This guide is solely for the use of the end-user to become more knowledgeable with the fire suppression system and the steps necessary in the event of a fire.

Should the end-user want to find out more information concerning the ANSUL Restaurant Fire Suppression System, your authorized ANSUL distributor can furnish a detailed Installation, Operation, Recharge, Inspection, and Maintenance Manual.

### YOUR ROLE IN FIRE PROTECTION

Your ANSUL Fire Suppression System is of the highest quality. It has been carefully engineered to be reliable, manufactured to exacting standards, proven by over 30 years of service, and custom designed to protect your particular hazard.

If properly maintained, your system should provide years of protection. However, the primary objective of this guide is to provide enough basic information to help you to prevent a disastrous fire. By observing some fundamental rules, you can greatly reduce the risk of serious fire damage.

- ▶ 1. Keep all kitchen equipment free of grease build-up, including gas flues which are not intended to be grease coated.
- ▶ 2. Never use flammable solvents or cleaners. Flammable residues could be left in the hazard area.
- ▶ 3. Never store flammable materials near cooking equipment or gas flue areas.
- ▶ 4. Make certain obstructions, such as utensils, pots, pans, cooking materials, etc., are not stored in areas that can obstruct the fire suppression system discharge.
- ▶ 5. Operate your exhaust system whenever the appliance is pre-heating, heating, cooking or cooling. This helps to prevent excessive heat build up which could actuate the system.

- ▶ 6. Never operate filter-equipped exhaust systems without the filters in place. Excessive grease may build-up in the hood and duct system. Cooking with filters removed can impact air movement and/or temperatures, which may result in system discharge. Use only UL listed filters.
- ▶ 7. Never restrict air intake passages; this can reduce the efficiency of your exhaust system. Cooking with filters that contain excessive amounts of grease can impact air movement and/or temperatures, which may result in system discharge.
- ▶ 8. Operate all UL tested grease extractors by the manufacturer's instructions to ensure effective grease removal from the hood and duct system.
- ▶ 9. Never tamper with the system components (i.e., detectors, nozzles, agent storage container(s) or releasing unit(s)).
- ▶ 10. Before you revise your kitchen equipment layout or make changes which affect the basic configuration of the protected area, contact your trained, authorized ANSUL distributor for a system update evaluation. The system is made up of components tested within limitations contained in the detailed installation manual. The system designer must be consulted whenever changes are planned for the system or area of protection.
- ▶ 11. Do not allow anyone except an authorized ANSUL distributor to perform maintenance on your ANSUL system. Maintenance to your system must be performed semi-annually. It is essential that the system be maintained properly.
- ▶ 12. Post operating instructions in an obvious place in the kitchen and make sure your employees know what to do in case of fire.
- ▶ 13. Make certain that hand portable extinguishers are properly placed and compatible with the restaurant system. An authorized ANSUL distributor can assist your needs.

# OWNER'S GUIDE

## R-102™ RESTAURANT FIRE SUPPRESSION SYSTEM

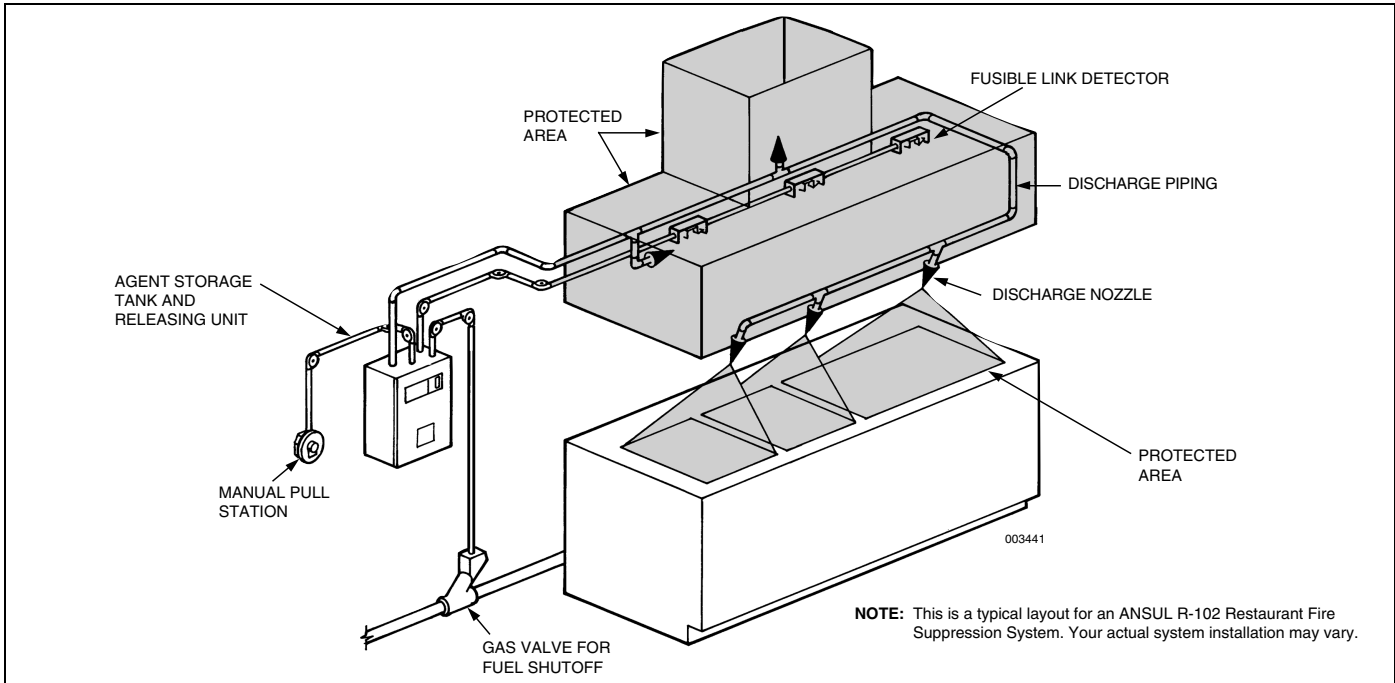

### HOW THE ANSUL R-102 SYSTEM OPERATES

1. A fire starts in the protected area...
2. Heat sensitive fusible link detectors activate the system.
3. Appliance energy sources are automatically shut off by accessory equipment appropriate for the type of fuel used by your cooking equipment.
4. The fire extinguishing agent is discharged into the plenum and duct and onto the cooking appliances.
5. The agent and the hot grease mix to form a foam. This temporarily seals combustible vapors, helping to inhibit re-ignition. This seal must not be disturbed.

### INSPECTING YOUR R-102 SYSTEM

Your ANSUL R-102 system should be inspected at least monthly. **Should you discover any irregularities, contact an authorized ANSUL distributor immediately.**

1. Never use corrosive cleaning solutions on the fusible links or cables. Check to make certain there is no corrosion to any of the detection system components. Certain high alkaline cleaners could cause corrosion.
- ▶ 2. Ensure that metal fusible links are replaced semi-annually. Deterioration of these links could cause the system to be actuated or to malfunction in case of a fire.
3. Make certain the releasing unit has not been tampered with, and that visual inspection seals are not broken or missing.
4. At daily intervals check your system for loose pipes and missing or grease covered nozzle caps. Make certain

nozzle caps are in place over the ends of each nozzle. Temporarily remove cap, check to make certain it is not brittle, and snap back on nozzle.

**Note:** If caps are damaged or missing, contact the authorized ANSUL distributor for immediate replacement.

5. Check each metal blow-off cap and make certain the cap can be turned freely on the nozzle.
6. Periodically check your visual indicator on the releasing unit to make certain the system is cocked.
7. Have your system inspected by an authorized ANSUL distributor at a maximum of 6 month intervals and immediately after major hood and duct cleaning. Often fusible links are wired shut during the cleaning process to prevent accidental activation. This will prevent the system from operating automatically. It's also possible that your system might have been disconnected, damaged, or has accumulated excessive deposits of grease causing your system to become inoperative.
8. Check that the manual pull station is not obstructed, has not been tampered with, and is ready for operation.
9. Make certain that each tank and releasing unit is mounted in an area with a temperature range of 32 °F to 130 °F (0 °C to 54 °C).
10. Make certain the agent storage tank is not in an area in which the temperature can exceed 130 °F (54 °C) or can be heated to a temperature exceeding 130 °F (54 °C) due to conductivity through heated discharge piping.

# OWNER'S GUIDE

## R-102™ RESTAURANT FIRE SUPPRESSION SYSTEM

### IN THE EVENT OF FIRE IN THE PROTECTED AREA

1. Evacuate others from the premises. In a loud, clear voice say: "WE HAVE A FIRE—PLEASE LEAVE THE BUILDING CAREFULLY, BUT QUICKLY."

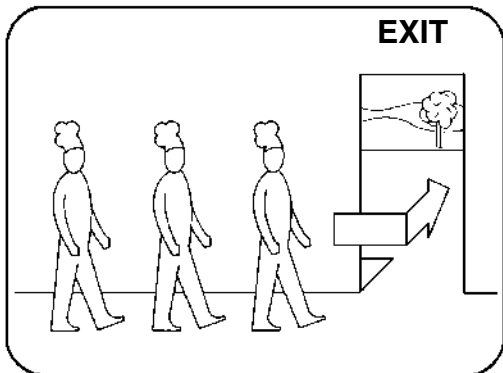

001633

2. If the automatic actuation has not yet taken place, operate the system manually as follows:

- Pull handle or pull ring straight out on manual pull station with enough force to actuate the fire suppression system.

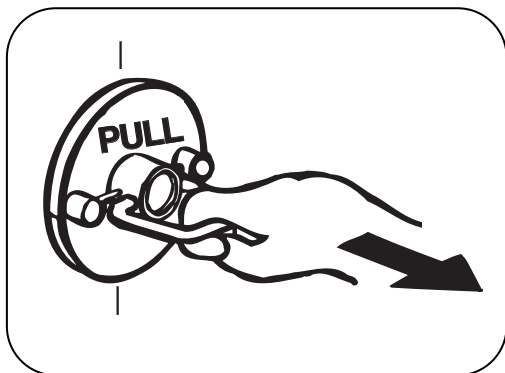

006856a

Once the fire suppression system is actuated, equipment to shut off the fuel supply to the cooking appliances will operate.

- ▶ 3. Call the local fire department or emergency number.

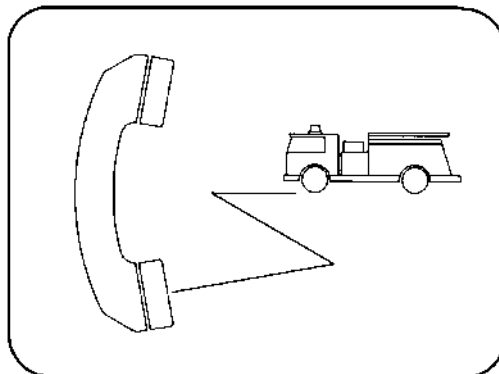

001635

- ▶ 4. Stand by with a K-GUARD® wet chemical hand portable fire extinguisher.

If you need to use it:

- a. Pull pin
- ▶ b. Stand back 10 ft (3.0 m)
- c. Aim at base of fire, squeeze handle and sweep side to side

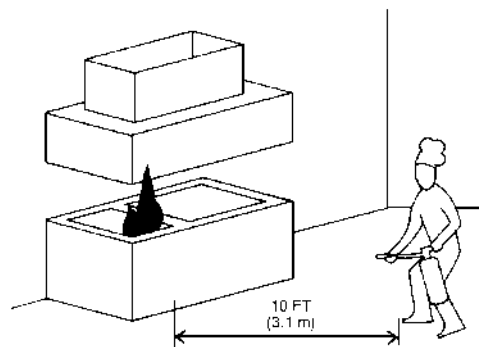

### CAUTION

1. Do not attempt to extinguish a grease fire with a hand portable fire extinguisher before the Fire Suppression System has been manually or automatically actuated.
2. Do not discharge wet chemical agent from the K-GUARD Wet Chemical hand portable fire extinguisher unless the fire suppression system will not operate or a re-flash has occurred.
3. Do not attempt to use a Class ABC Multipurpose Dry Chemical, CO<sub>2</sub>, or Water type hand portable fire extinguisher in/on an appliance with burning cooking oil or grease.

# OWNER'S GUIDE

## R-102™ RESTAURANT FIRE SUPPRESSION SYSTEM

### BEFORE RESUMING BUSINESS

1. Immediately after discharge, call your authorized ANSUL distributor to inspect and recharge your Fire Suppression System.
2. Have your ANSUL distributor determine the cause of the system actuation.
3. Area must be cleaned up within 24 hours after discharge using warm water and cleaning detergents.

### CLEANUP PROCEDURES

Although there is no unusual cleanup procedure of ANSULEX® or ANSULEX LpH agents, due to the alkaline nature of these agents, they should be cleaned from kitchen surfaces within 24 hours after system discharge. The reaction from the wet chemical agent on cooking grease or oil produces a foamy bi-product that can be wiped up with a cloth or sponge. The following procedures should be followed:

#### CAUTION

- ▶ 1. Before attempting any cleanup, make certain that all fuel sources to the equipment to be cleaned have been shut off. Make certain that the exhaust hood and all appliance electrical controls have been de-energized to avoid any chance of electrical shock resulting from the cleaning process or from electrically conductive alkaline liquid agent and/or its residue.
  - ▶ 2. Make certain all surfaces to be cleaned have cooled down to room temperature.
  - ▶ 3. Do not use water to clean any appliances that contain hot grease or cooking oils. Doing so may result in violent steaming and/or spattering.
1. The fire suppression system agent is non-toxic; however, food product and cooking grease/oil that has come in contact with the agent will no longer be suitable for human consumption and should be discarded.
  2. Sponge as much of the agent as possible using sponges or clean rags. Dispose of these sponges or rags in a local sanitary land fill site in accordance to local authorities.
- Note:** Wear rubber gloves during cleanup as sensitive skin may become irritated. If the ANSULEX agent or its residue comes in contact with skin or eyes, flush thoroughly with clean water.

3. Using hot, soapy water and either a clean cloth or sponge, wipe away all foamy residue and thoroughly scrub all surfaces that have come in contact with the agent. **Note:** Wear rubber gloves during cleanup as sensitive skin may become irritated. If the ANSULEX agent or its residue comes in contact with skin or eyes, flush thoroughly with clean water.
4. After thoroughly cleaning all affected surfaces, adequately rinse and allow to completely dry before re-energizing the equipment.

### WARRANTY

#### A. Ansul Products

Except as indicated in B below, your R-102 System is warranted to you as the original purchaser for five years from date of delivery against defects in workmanship and material. Ansul Incorporated ("ANSUL") will replace or repair any metal part which, in its opinion, is defective and has not been tampered with or subjected to misuse, abuse or exposed to highly corrosive conditions.

#### B. Purchased Products

The following items which are not manufactured but purchased by ANSUL are warranted against defects resulting from the manufacturer's fabrication, process or parts for one year from the date of purchase: detectors, electric manual pull station, time delay relays, thermostats, solenoids, switches, fuel shut-off valves, and pressure relief valves. Evaluation of each reportedly defective relay, valve, etc., returned to ANSUL will be made by the original manufacturer or an agent thereof and their judgment shall be final.

**C.** Except as provided in A and B, there are no warranties, express or implied made by ANSUL, concerning this system. There are no implied warranties of FITNESS FOR PURPOSE OR MERCHANTABILITY. ANSUL shall have no liability for consequential, special or similar damages.

For repairs, parts and service of the ANSUL System, contact your local ANSUL representative, or Ansul Incorporated, Marinette, Wisconsin 54143-2542; 800-TO-ANSUL (862-6785).