

Installation, Operation and Maintenance Manual

Please read and save these instructions for future reference. Read carefully before attempting to assemble, install, operate or maintain the product described. Protect yourself and others by observing all safety information. Failure to comply with these instructions will result in voiding of the product warranty and may result in personal injury and/or property damage.

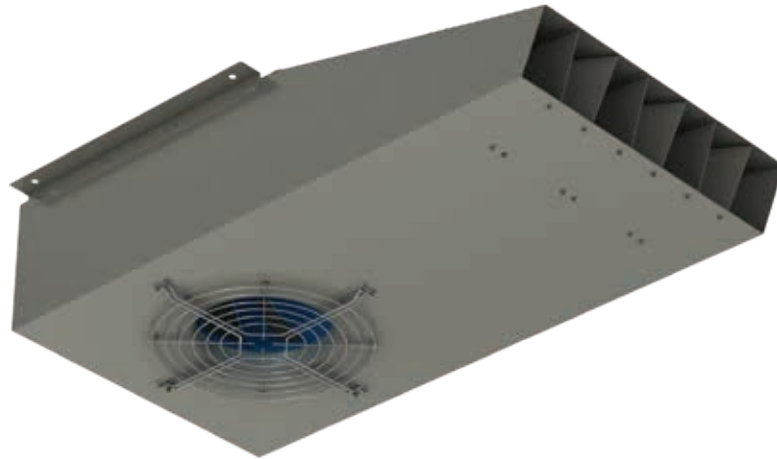

General Safety Information

Only qualified personnel should install this fan. Personnel should have a clear understanding of these instructions and should be aware of general safety precautions. Improper installation can result in electric shock, possible injury due to coming in contact with moving parts, as well as other potential hazards. Other considerations may be required if high winds or seismic activity are present. If more information is needed, contact a licensed professional engineer before moving forward.

1. Follow all local electrical and safety codes, as well as the National Electrical Code (NEC), the National Fire Protection Agency (NFPA), where applicable. Follow the Canadian Electrical Code (CEC) in Canada.
2. The rotation of the wheel is critical. It must be free to rotate without striking or rubbing any stationary objects.
3. Motor must be securely and adequately grounded.
4. Do not allow the power cable to kink or come in contact with oil, grease, hot surfaces, or chemicals. Replace cord immediately if damaged.
5. Verify the power source is compatible with the equipment.

Features

Input speed control options:
0-10VDC signal
MODBUS Communications

DANGER

Always disconnect, lock and tag power source before installing or servicing. Failure to disconnect power source can result in fire, shock or serious injury.

CAUTION

When servicing the fan, motor may be hot enough to cause pain or injury. Allow motor to cool before servicing.

CAUTION

Precaution should be taken in explosive atmospheres.

Receiving

Upon receiving the product, check to ensure all items are accounted for by referencing the delivery receipt or packing list. Inspect each crate or carton for shipping damage before accepting delivery. Alert the carrier of any damage detected. The customer will make a notation of damage (or shortage of items) on the delivery receipt and all copies of the bill of lading which is countersigned by the delivering carrier. If damaged, immediately contact your local sales representative. Any physical damage to the unit after acceptance is not the responsibility of the manufacturer.

Unpacking

Verify that all required parts and the correct quantity of each item have been received. If any items are missing; report shortages to your local representative to arrange for obtaining missing parts. Sometimes it is not possible that all items for the unit be shipped together due to availability of transportation and truck space. Confirmation of shipment(s) must be limited to only items on the bill of lading.

Handling

Handle in such a manner as to keep from scratching or chipping the coating. Damaged finish to parts may reduce ability of unit to resist corrosion.

Fans are to be lifted using a minimum of four (4) points on the fan housing or attach two suitable chains / straps around the entire fan housing.

Storage

Fans are protected against damage during shipment. If the unit cannot be installed and operated immediately, precautions need to be taken to prevent deterioration of the unit during storage. The user assumes responsibility of the unit and accessories while in storage. The manufacturer will not be responsible for damage during storage. These suggestions are provided solely as a convenience to the user.

INDOOR - The ideal environment for the storage of units and accessories is indoors, above grade, in a low humidity atmosphere which is sealed to prevent the entry of blowing dust, rain, or snow. Temperatures should be evenly maintained between 30°F (-1°C) and 110°F (43°C) (wide temperature swings may cause condensation and “sweating” of metal parts).

All accessories must be stored indoors in a clean, dry atmosphere.

Remove any accumulations of dirt, water, ice, or snow and wipe dry before moving to indoor storage. To avoid “sweating” of metal parts, allow cold parts to reach room temperature. To dry parts and packages use a portable electric heater to eliminate any moisture build up. Leave coverings loose to permit air circulation and to allow for periodic inspection.

The unit should be stored at least 3-1/2 in. (89 mm) off the floor on wooden blocks covered with moisture proof paper or polyethylene sheathing. Aisles between parts and along all walls should be provided to permit air circulation and space for inspection.

Removing From Storage

As units are removed from storage to be installed in their final location, they should be protected and maintained in a similar fashion, until the equipment goes into operation. Prior to installing the fan and system components, inspect the unit assembly to make sure it is in working order. Check all fasteners and accessories for tightness.

General Information

To ensure a successful installation, the instructions in this manual should be read and adhered to. Failure to comply with proper installation procedures may void the warranty.

Unit and System Identification Tags

Each fan has a permanently affixed manufacturer's engraved metal nameplate containing the model number and individual serial number.

The tag shown is an example of an identification nameplate on the fan. The information provides general details about the fan, as well as containing

specific information unique to the unit. When contacting your local sales representative with future needs or questions, please have the information on this label available. Tags are mounted in an area which is clearly visible.

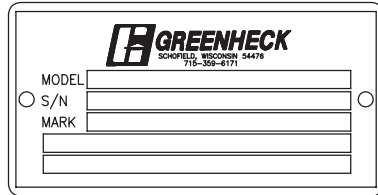

Pre-Installation Information

Before installation, it is important to be certain the mounting surface will bear the operating weight of the unit. For proper unit operation, it is also important that it be operated in a completely level position.

For further details on safety practices involving industrial and commercial fans, please refer to AMCA Publication 410.

Electrical Disconnects

Fan is provided with an integrated service disconnect. Service disconnects shall be locked-out when maintenance is being performed.

Moving Parts

All moving parts must have guards to protect personnel. Refer to local codes for requirements as to the number, type and design. The fan wheel may start “free wheeling” even if all electrical power has been disconnected. Before the initial start-up or any restart, check the following items to make sure that they are installed and secure.

- Do not spin fan wheel faster than the maximum cataloged fan rpm.

Guards

Do not operate fans without proper protective devices in place. Failure to do so may result in serious bodily injury and property damage. Check local codes to ensure compliance for all protective devices.

Air Pressure and Suction

In addition to the usual hazards associated with rotating machinery, fans also create a dangerous suction at the inlet. Special caution needs to be used when moving around a fan, whether it is in operation or not. Before start-up, make sure the inlet area is clear of personnel and loose objects.

Typical Installation

Fan Mounting

The GJI model fan is designed for horizontal ceiling mount applications. The fan should be mounted either rigidly or using vibration isolators.

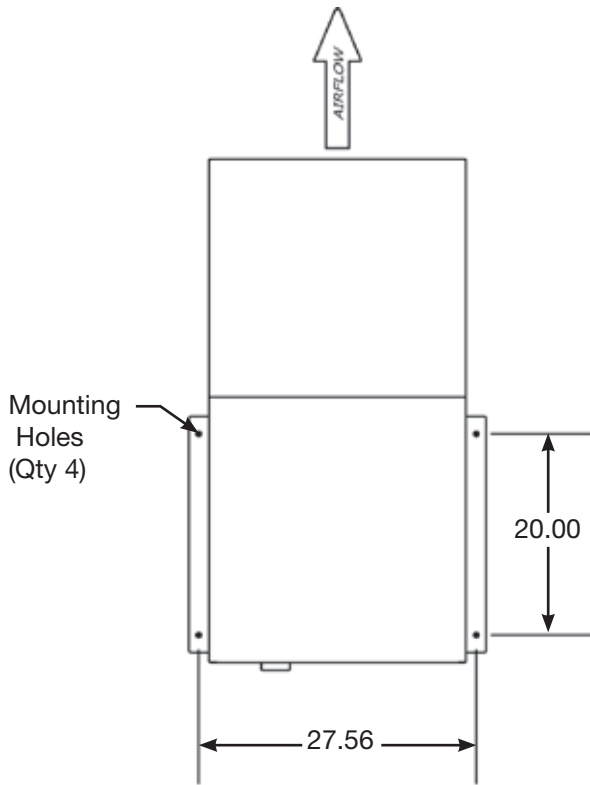

Figure 1 – Top view of GJI mounting hole locations when ordered without isolators

Mounting holes are 7/16 inch when isolators are provided by others. Mounting holes are cut to 1-3/16 inch when isolators are provided by Greenheck.

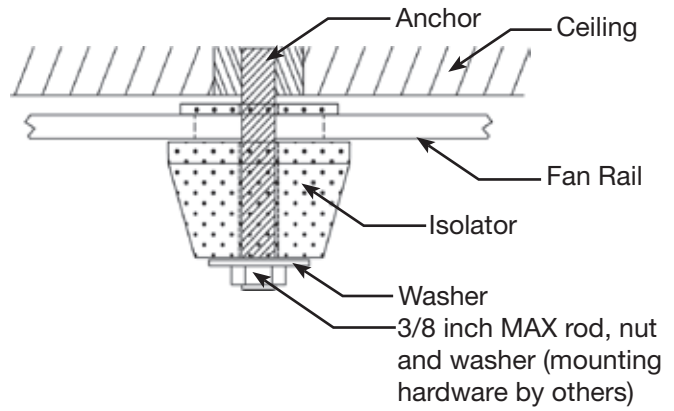

Figure 2 – Mounting GJI model to a ceiling utilizing Greenheck provided neoprene isolator (hardware by others)

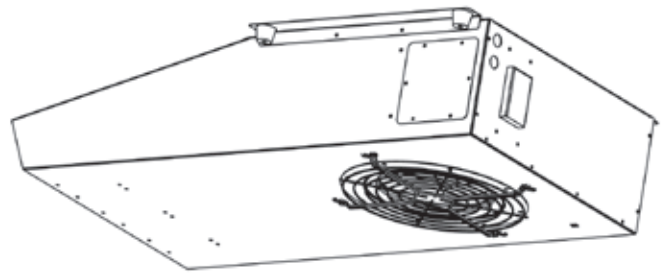

Figure 3 – Illustration showing isolators mounted under fan rails

CAUTION

All products must be installed and maintained according to instructions to ensure proper operation. Only qualified technicians should install and maintain the equipment.

Electrical

NOTE

All field installation and wiring of electrical equipment must be done to meet NEC, CEC and local codes.

Must use appropriately sized wire for the full load amp draw.

When the hardwiring is complete, please refer to the BMS Communication section for details on communication via the hard wire connections.

The GJI fan requires single phase 208-277V 50/60 Hz power. Amperage ranges from 2.4 ~ 1.85A depending on voltage. The motor also requires either a 0-10VDC or MODBUS signal to control the fan speed.

Particular attention should be given when connecting power to the unit. Supply wiring must be properly fused and conform to local and national electrical codes.

Two electrical knockouts are located on the back of the unit (Figure 4). Utilize one knockout for motor power supply and the second for control wiring. Each set of wiring connections are to be run separately into the unit.

To access the wiring terminal strip, remove the electrical access panel (Figure 5). Motor supply power and control wires are connected to a terminal strip as shown in the wiring diagram on the backcover (Figure 7).

After the electrical connections have been made secure, reattach the access panel back into position.

Electrical Data					
Phase	1 (Single)				
Hz	50 / 60				
Voltage	208	220	230	240	277
MCA	3.0	2.8	2.7	2.6	2.3
MOP	15A				

0-10 VDC or MODBUS control signal required for operation

Figure 4 – Back Panel

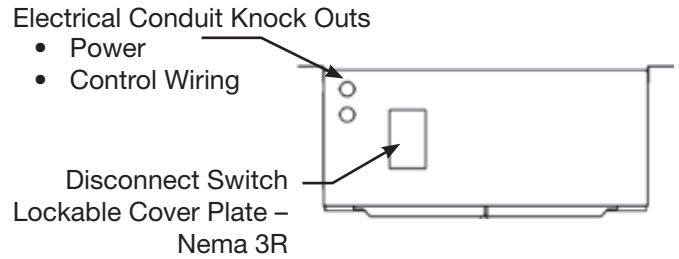
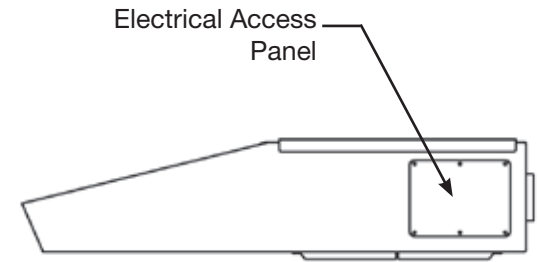

Figure 5 – Side Panel



BMS Communication & Speed Control

Networking via MODBUS-RTU

The device comes equipped with a RS-485 interface for networking via MODBUS. Connection at: SI G-, MDBS+1 and MDBS-1.

The address must be set in the IO Setup menu.

RS-485 - Network Design and Interface Parameter

Ensure the correct connection; i.e. MDBS-1 must always be connected to MDBS-1 of the next device. The same applies to MD+1.

A “GND” connection must be established, as dissimilar to potential (over 10V) will lead to the destruction of the RS-485 interface (e.g. lightning).

Always use two wires of one lead (twisted pair) for connection.

Recommended Wire Types

1. CAT5 / CAT7 cables
2. J-Y (St) 2x2x0.6 (telephone wire)
3. AWG22 (2x2 twisted pair)

When using telephone flex with four cable cores, it is recommended the following allocation:

“A (D+)” = red, “B (D-)” = black, “GND” = white

Pay attention to sufficient distance from power lines and motor wires (min. 8 inches).

Max allowed wire length 3,280 feet (CAT5/7 500 m).

RS-485 Communication

MODBUS follows a simple master/slave model. Slave devices perform data read/write requests which are issued from a client device such as a PLC or building management system. Assignable addresses for server devices range from an address of 1 to theoretical maximum of 247. For a complete address list or motor control questions, please contact Ziehl Abegg support center at 336-834-9339. Default communication parameters for serial MODBUS communication can be found below.

- COM Bus Address: 247
- COM Baud rate: 19200 Bd
- COM Mode: 8E1
- Bits = 8
- Parity = Even
- Stop bits = 1
- Handshake = None

MODBUS Read Communication

Input Register Address	Full Parameter Name	Parameter Setting
14	Speed	Decimal value 0-65535 RPM
15	Motor Current	Decimal value 0-65535 (in 0.01 A steps)
21	Line Voltage	Decimal value 0-65535 (in 1 V steps)
25	Motor Temperature	Decimal value 0-65535 (in 0.1 degrees C steps)

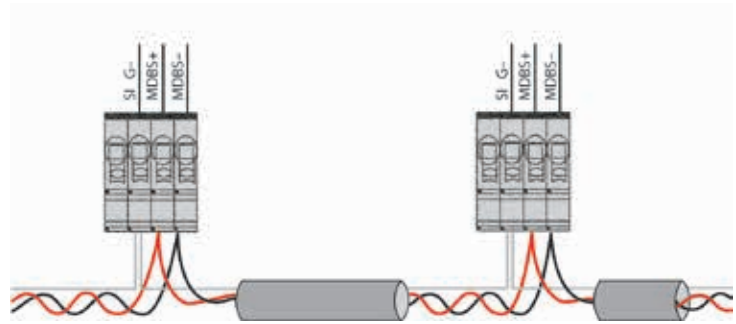

Figure 6 - General example for MODBUS device connection

Controller Setup

MB Holding Register 4, Address: h3	COM Parameter
Communication parameters for serial MODBUS communication. Settings made in this register will be made active after a device reset or by entering a PIN code, press h0.	
Access / necessary PIN protection level	RW, NV / <input type="checkbox"/>
Minimal value	0
Maximum value	65535
Bit [15:8]	Bus Address: 1 - 247, Default 247
Bit [7:4]	COM Baudrate: 19200Bd (default) 0 = 4800 1 = 9600 2 = 19200 (fix @: ECblue lite IP54, ECblue motor size B IP54) 3 = 38400 (only AM-MODBUS) 4 = 115200 (only AM-MODBUS from Firmware 04)
Bit [3:0]	COM Mode 8E1 (default) 0 = 8N1 1 = 8O1 2 = 8E1 (fix @: ECblue lite IP54, ECblue motor size B IP54) 3 = 8N2 (from AM-MODBUS version 9.00)

MB Holding Register 3, Address: h2	Speed control
Used for speed control of the device. The interpretation of the value depends on control mode register (h4) Bit [3:0].	
Access / necessary PIN protection level	RW / <input type="checkbox"/>
Minimal value	0
Maximum value	65535
Default	0
Bit [15:0]	Decimal value 0 - 65535

Maintenance

General maintenance for the GJI model:

- Motor bearings are sealed and do not need lubrication.
- Inspection and cleaning should be limited to remove any dirt accumulation on the fan wheel, fan inlet and fan discharge.

If the fan environment possesses a consistent humidity of 80% or more, the fan must be run for 2 hours on high, once a month to remove condensation.

Paint Touch-Up for Scratched Areas

For field paint repairs, refer to replacement part HAZ2920 Concrete Gray, Touch Up Paint, Spray Can RAL 7023.

Troubleshooting

Problem	Cause	Corrective Action
Excessive noise	Wheel unbalance	Clean all dirt off wheel. Check wheel balance, replace if necessary.
	Impeller blocked	Inspect and remove debris from inlet and outlet.
Fan doesn't operate	Electrical supply	Check fuses/circuit breakers. Check for switches turned off or disconnected. Check for correct supply voltage.
	Control signal	Verify control signal and wiring. Check connections to terminal strip.
Low airflow	Inlet / outlet blocked	Remove debris from inlet and outlet.

* Excessive fan speed may overload the motor and result in motor failure. Do not exceed the maximum cataloged rpm of the fan.

Figure 7 – GJI wiring diagram

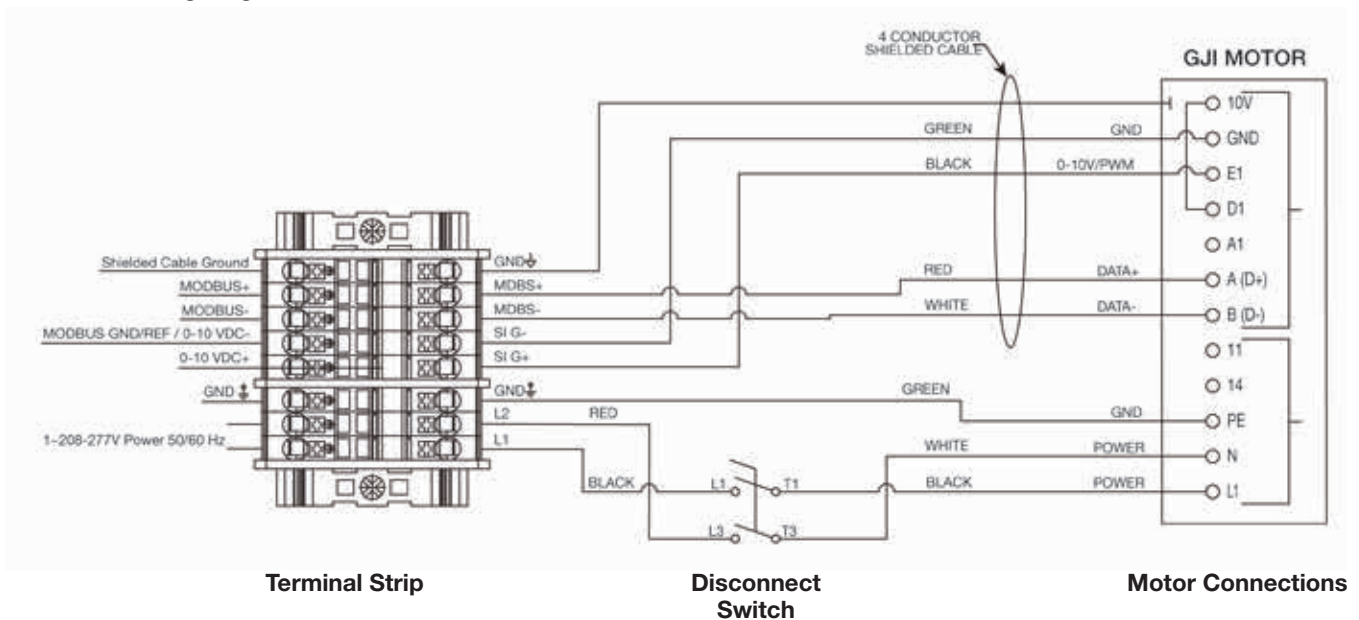

Our Commitment

As a result of our commitment to continuous improvement, Greenheck reserves the right to change specifications without notice.

Product warranties can be found online at Greenheck.com, either on the specific product page or in the literature section of the website at Greenheck.com/Resources/Library/Literature.

Greenheck's GreenJet Jet Fans catalog provides additional information describing the equipment, fan performance, available accessories, and specification data.

