

Installation, Operation and Maintenance Manual

Please read and save these instructions for future reference. Read carefully before attempting to assemble, install, operate or maintain the product described. Protect yourself and others by observing all safety information. Failure to comply with these instructions will result in voiding of the product warranty and may result in personal injury and/or property damage.

Square Mixed Flow Inline Fans

Fans are direct-driven with mixed flow wheels and feature ridged construction, high-efficiency and low sound levels. These compact inline fans are the ideal selection for indoor clean air applications including intake, exhaust, return, or make-up air systems. The square housing design, compact size, and straight-thru airflow also provide the system designer the flexibility to mount in horizontal and vertical orientations. Each fan displays a permanently stamped metal nameplate with complete model number, mark, and unique serial number for future identification.

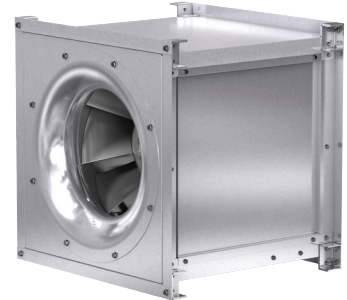

General Safety Information

Only qualified personnel should install this fan. Personnel should have a clear understanding of these instructions and should be aware of general safety precautions. Improper installation can result in electric shock, possible injury due to coming in contact with moving parts, as well as other potential hazards. Other considerations may be required if seismic activity is present. If more information is needed, contact a licensed professional engineer before moving forward.

1. Follow all local electrical and safety codes, as well as the National Electrical Code (NEC) and the National Fire Protection Agency (NFPA), where applicable. Follow the Canadian Electric Code (CEC) in Canada.
2. The rotation of the wheel is critical. It must be free to rotate without striking or rubbing any stationary objects.
3. Motor must be securely and adequately grounded.
4. Do not spin fan wheel faster than max cataloged fan RPM or this could cause catastrophic wheel failure. Adjustments to fan speed significantly affects motor load. If the fan RPM is changed, the motor current should be checked to make sure it is not exceeding the motor nameplate amps.
5. Do not allow the power cable to kink or come in contact with oil, grease, hot surfaces or chemicals. Replace cord immediately if damaged.
6. Verify that the power source is compatible with the equipment.
7. Never open access doors to a duct while the fan is running.
8. Never remove covers protecting electrical components while fan is energized.

DANGER

Always disconnect, lock and tag power source before installing or servicing. Failure to disconnect power source can result in fire, shock or serious injury.

CAUTION

When servicing the fan, motor may be hot enough to cause pain or injury. Allow motor to cool before servicing.

CAUTION

Precaution should be taken in explosive atmospheres.

DANGER

Pour écarter les risques d'incendie, de choc électrique ou de blessure grave, veiller à toujours débrancher, verrouiller et étiqueter la source de courant avant l'installation ou l'entretien.

ATTENTION

Lors de toute intervention sur la soufflante, le moteur peut être suffisamment chaud pour provoquer une douleur voire une blessure. Laisser le moteur refroidir avant toute maintenance.

ATTENTION

Faire preuve de précaution dans les atmosphères explosives.

Receiving

Upon receiving the product check to ensure all items are accounted for by referencing the delivery receipt or packing list. Inspect each crate or carton for shipping damage before accepting delivery. Alert the carrier of any damage detected. The customer will make a notation of damage (or shortage of items) on the delivery receipt and all copies of the bill of lading which is countersigned by the delivering carrier. If damaged, immediately contact your local representative. Any physical damage to the unit after acceptance is not the responsibility of the manufacturer.

Unpacking

Verify that all required parts and the correct quantity of each item have been received. If any items are missing, report shortages to your local representative to arrange for obtaining missing parts. Sometimes it is not possible that all items for the unit be shipped together due to availability of transportation and truck space. Confirmation of shipment(s) must be limited to only items on the bill of lading.

Handling

Move fan to desired location and determine position of access panels, discharge and motor. Make sure the inlet and outlet have at least 2-1/2 times the wheel diameter (duct diameter) of straight duct before any obstructions like an elbow or transition. Attach the fan to a suitable framework as specified by others; hanging or base vibration isolators are recommended. See corresponding Fan Dimensions tables; page 3 for physical dimensions. The motor's amperage and voltage ratings must be checked for compatibility to supply power prior to final electrical connection. Electrical lead-in wires are then connected to the electrical wires run to the external factory supplied junction box. All wiring must conform to local and national codes.

Storage

Fans are protected against damage during shipment. If the unit cannot be installed and operated immediately, precautions need to be taken to prevent deterioration of the unit during storage. The user assumes responsibility of the fan and accessories while in storage. The manufacturer will not be responsible for damage during storage. These suggestions are provided solely as a convenience to the user.

Indoor Storage: The ideal environment for the storage of fans and accessories is indoors, above grade, in a low humidity atmosphere which is sealed to prevent the entry of blowing dust, rain or snow. Temperatures should be evenly maintained between 30° to 110°F (-1° to 43°C) (wide temperature swings may cause condensation and “sweating” of metal parts). All accessories must be stored indoors in a clean, dry atmosphere.

Remove any accumulations of dirt, water, ice or snow and wipe dry before moving to indoor storage. To avoid “sweating” of metal parts allow cold parts to reach room temperature. To dry parts and packages, use a portable electric heater to get rid of any moisture buildup. Leave coverings loose to permit air circulation and to allow for periodic inspection.

The unit should be stored at least 3-1/2 inches (89 mm) off the floor on wooden blocks covered with moisture proof paper or polyethylene sheathing. Aisles between parts and along all walls should be provided to permit air circulation and space for inspection.

Inspection & Maintenance During Storage

While in storage, inspect fans once per month. Keep a record of inspection and maintenance performed.

If moisture or dirt accumulations are found on parts, the source should be located and eliminated. At each inspection, rotate the wheel by hand ten to fifteen revolutions to distribute lubricant in motor. If paint deterioration begins, consideration should be given to touch-up or repainting. Fans with special coatings may require special techniques for touch-up or repair.

Machined parts coated with rust preventive should be restored to good condition promptly if signs of rust occur. Immediately remove the original rust preventive coating with petroleum solvent and clean with lint-free cloths. Polish any remaining rust from surface with crocus cloth or fine emery paper and oil. Do not destroy the continuity of the surfaces. Thoroughly wipe clean with Tectyl® 506 (Ashland Inc.) or the equivalent. For hard to reach internal surfaces or for occasional use, consider using Tectyl® 511M Rust Preventive, WD-40® or the equivalent.

Removing From Storage

As fans are removed from storage to be installed in their final location, they should be protected and maintained in a similar fashion until the fan equipment goes into operation.

Dimensional Data

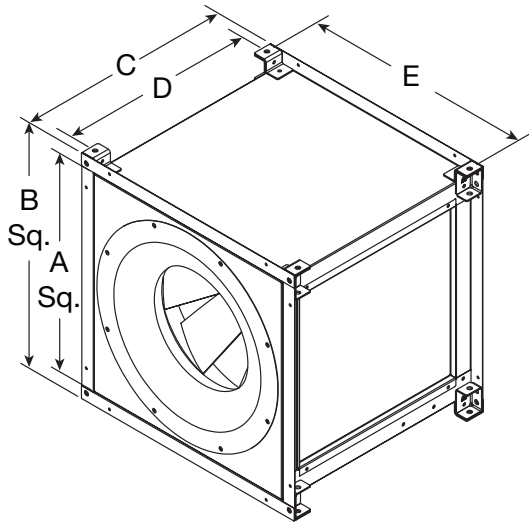

Figure 1 – Standard Mount Configuration

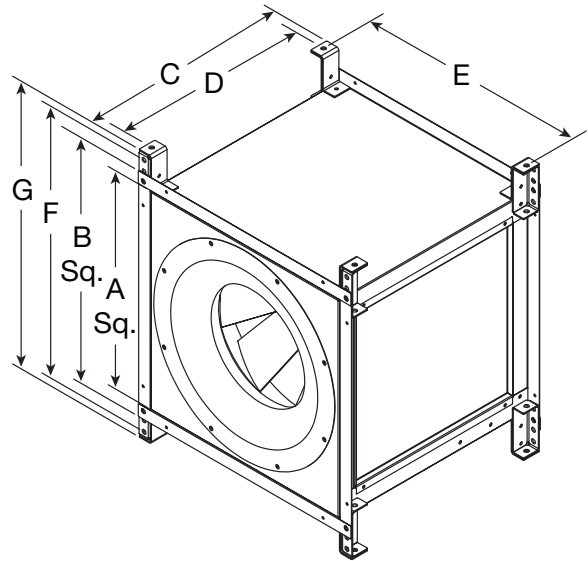

Figure 2 – Universal Mount Configuration with Tall Brackets

Fan Size	A Sq.	B Sq.	C	D	E	F	G	Weight [^]
16	24 (610)	27 (686)	24 (610)	21.80 (554)	25.75 (654)	29.88 (759)	31.63 (803)	171 (78)
18	26.59 (675)	29.59 (752)	26.59 (675)	24.39 (620)	28.34 (720)	32.46 (825)	34.21 (869)	186 (84)
20	29.18 (741)	32.18 (817)	29.18 (741)	26.98 (685)	30.93 (785)	35.05 (890)	36.80 (935)	200 (91)
22	32.05 (814)	35.05 (890)	32.05 (814)	29.85 (758)	33.80 (859)	37.93 (963)	39.68 (1008)	392 (178)
24	35.50 (902)	38.50 (978)	35.50 (902)	33.30 (846)	37.25 (946)	41.38 (1051)	43.13 (1095)	420 (190)
27	38.95 (989)	41.95 (1066)	38.95 (989)	36.67 (931)	40.78 (1036)	44.83 (1139)	46.58 (1183)	606 (275)
30	42.98 (1092)	45.98 (1168)	42.98 (1092)	40.70 (1034)	44.81 (1138)	48.85 (1241)	50.60 (1285)	656 (298)
33	47.29 (1201)	50.29 (1277)	47.29 (1201)	45.01 (1143)	49.12 (1248)	53.16 (1350)	54.91 (1395)	862 (391)

All dimensions in inches (millimeters) and weight is shown in pounds (kilograms). [^]Weight shown is standard galvanized construction and largest cataloged totally enclosed motor. Dimensions A and B are same for height and width.

Mounting

IMPORTANT

Flex duct is recommended for mounting to the inlet of the fan to allow for fitting adjustments. If the inlet cone (venturi) requires adjustment, it can be detached from the unit via the fasteners located on the inlet panel.

IMPORTANT

The inlet and outlet duct should have approximately two to three wheel diameters of straight duct before and after the fan to achieve cataloged performance.

Standard Mount: This is the standard product configuration and requires the fan to be installed so airflow direction is horizontal and fan is installed with motor sitting directly over or under the motor mount plate.

Universal Mount: Selectable option for sizes 16 through 33. Allows fan to be installed for vertical airflow or horizontal airflow. In addition, the fan can be rotated 90 degrees either direction (access doors on the bottom and top).

NOTE: Fan size 22 and larger have additional internal structural supports.

Pre Start-Up Checks

Before Fan Installation

1. **Check all fasteners for tightness:** The wheel should rotate freely and be aligned as shown in Figure 3. Wheel position is preset and the unit is tested at the factory. Movement may occur during shipment, and realignment may be necessary. Centering can be accomplished by loosening the bolts holding the inlet cone (venturi) and repositioning.
2. **Wheel and inlet cone overlap:** Rotate the fan wheel by hand and assure no parts are rubbing. The wheel should rotate freely and be aligned as shown in Figure 3. Wheel position is preset and the unit is tested at the factory. Movement may occur during shipment, and realignment may be necessary.

Radial Gap - If necessary, adjust inlet cone position such that the radial gap between the wheel cone and inlet cone is evenly distributed around the wheel.

Alignment - If necessary, adjust wheel position by loosening the wheel hub from the fan shaft so that a straight edge held tight to the wheel cone just touches the inlet cone. Refer to Figure 3.

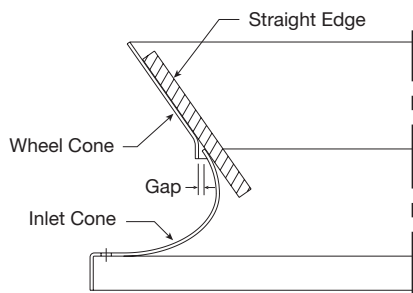

Figure 3

Operation

IMPORTANT

The fan has been checked for mechanical noises at the factory prior to shipment. If mechanical noise should develop, suggested corrective actions are offered in the Troubleshooting section (page 5).

1. After the fan is installed, disconnect and lock-out all power switches to fan.
2. Before starting up or operating fan, check all fasteners for tightness. In particular, check the cap screws in wheel bushing.
3. Before connecting the fan to power, turn the fan wheel by hand to be sure it is not striking the inlet cone (venturi) or any obstacle.
4. Start the fan and shut it off immediately to check rotation of the wheel, see Figure 4.

Wheel Rotation: Direction of wheel rotation is critical. Reversed rotation will result in poor air performance, motor overloading and possible burnout. Check wheel rotation by momentarily energizing the unit. Rotation should be counterclockwise when viewed from the fan inlet as shown in Figure 4. If wheel rotation is incorrect, switch two of the wiring leads for 3 phase power supply or check motor wiring for single phase power supply. Fan rpm should be checked and verified with a tachometer.

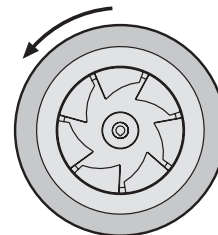

Figure 4

5. When the fan is started, observe the operation and check for any unusual noises.
6. With the system in full operation and all ductwork attached, measure current input to the motor and compare with the nameplate rating to determine if the motor is operating under safe load conditions.
7. Keep inlets and approaches to fan clean and free from obstruction.

Inspection

Inspection of the fan should be conducted at the first 30 minute and 24 hour intervals of satisfactory operation.

30 Minute Interval: Inspect bolts, setscrews and motor mounting bolts. Adjust and tighten as necessary.

24 Hour Interval: Check all internal components.

Troubleshooting

WARNING

Before taking any corrective action, make certain unit is not capable of operation during repairs.

AVERTISSEMENT

Avant d'entreprendre toute action corrective, s'assurer que l'appareil ne pourra pas fonctionner durant les réparations.

PROBLEM	CAUSE	CORRECTIVE ACTION
Excessive noise or vibration	Wheel unbalance	Clean all dirt off wheel. Check wheel balance, rebalance in place if necessary.
	Wheel improperly aligned and rubbing	Center wheel on inlet, see Figure 3.
	Foreign objects in wheel or housing	Remove objects, check for damage or unbalance.
Reduced airflow	System resistance too high	Check system: Proper operation of backdraft or control dampers, obstruction in ductwork, clean dirty filters.
	Unit running backwards	Correct. See Wheel Rotation on page 4.
	Excessive dirt buildup on wheel	Clean wheel.
	Improper wheel alignment	Center wheel on inlet, see Pre Start-Up Checks and Figure 3.

For Vari-Green® motor troubleshooting, refer to the Vari-Green Motor Installation, Operation and Maintenance Manual.

Maintenance

DANGER

Always disconnect, lock and tag power source before servicing. Failure to disconnect power source can result in fire, shock or serious injury.

WARNING

This unit should be made non-functional when cleaning the wheel or housing (fuses removed, disconnect locked off).

IMPORTANT

Uneven cleaning of the wheel will produce an out of balance condition that will cause vibration in the fan.

DANGER

Pour écarter les risques d'incendie, de choc électrique ou de blessure grave, veiller à toujours débrancher, verrouiller et étiqueter la source de courant avant l'installation ou l'entretien.

AVERTISSEMENT

L'appareil doit être rendu non opérationnel lors du nettoyage de la turbine ou du caisson (fusibles retirés, sectionneur verrouillé).

Installation and maintenance are to be performed only by qualified personnel who are familiar with local codes and regulations and who are experienced with this type of equipment.

Motor maintenance is generally limited to cleaning and lubrication (where applicable). Cleaning should be limited to exterior surfaces only. Removing dust buildup on motor housing ensures proper motor cooling.

Greasing of motors is only intended when fittings are provided. Many fractional horsepower motors are permanently lubricated and should not be lubricated after installation. Motors supplied with grease fittings should be greased in accordance with manufacturers' recommendations. Where motor temperatures do not exceed 104°F (40°C), the grease should be replaced after 2,000 hours of running time as a general rule.

Wheels require very little attention when moving clean air. Occasionally, oil and dust may accumulate causing imbalance. When this occurs the wheel and housing should be cleaned to ensure smooth and safe operation.

All fasteners should be checked for tightness each time maintenance checks are performed prior to restarting unit.

A proper maintenance program will help these units deliver years of dependable service.

Tapered Bushing Hub Installation and Removal

For wheel hubs utilizing a tapered bushing interface, follow this procedure for installation and removal.

Tapered Bushing Removal

1. If present, loosen the setscrew holding the bushing and shaft key in place.
2. Loosen and remove the socket head cap screws which fasten the bushing to the hub as shown in Figure 5.
3. Take the socket head cap screws that were removed and install them into the visibly threaded holes on the wheel hub.
4. Once socket head cap screws are installed, tighten them an eighth of a turn at a time, alternating until the hub comes loose from the bushing.

Bushing Installation

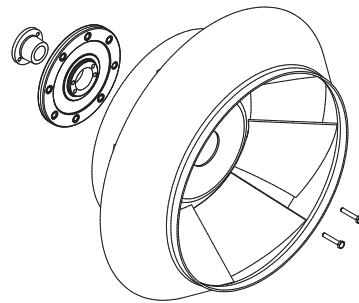

Figure 5

1. Clean all surfaces of hub and bushing to remove any oil or residue present and do not use any lubricant to install bushing into the hub. The socket head cap screws are adjustable from the inlet of the fan.
2. Slide the bushing and shaft key onto the fan shaft followed by the wheel and hub assembly. If present, use the keyway setscrew to hold the shaft key and bushing in place but DO NOT overtighten as this can damage the bushing. Align the unthreaded holes of the hub with the threaded holes of the tapered bushing.
3. Install the bushing socket head cap screws into the aligned holes by hand (or without excessive torque).
4. Adjust the axial location of the wheel in the fan relative to the inlet cone (venturi). Then tighten the socket head cap screws an eighth turn at a time in an alternating fashion and to a torque of 10 ft·lbs for QT bushings and 9 ft·lbs for SD bushings.

NOTE: QT or SD is shown on the outer edge of the bushing. QT bushings have two cap screws and SD bushings have three cap screws.

Parts List

Each fan bears a manufacturer's nameplate with model number and serial number embossed. This information will assist the local Greenheck representative and the factory in providing service and replacement parts. Before taking any corrective action, make certain unit is not capable of operation during repairs.

CAUTION

A fan manufactured with an explosion resistant motor does not certify the entire unit to be explosion resistant. Refer to UL Listing Mark for the fans approved usage.

ATTENTION

La présence d'un moteur antidéflagrant sur un ventilateur ne garantit pas que tout l'appareil est antidéflagrant. Pour connaître les emplois autorisés de l'appareil, voir son marquage de conformité UL.

Standard Orientation Construction

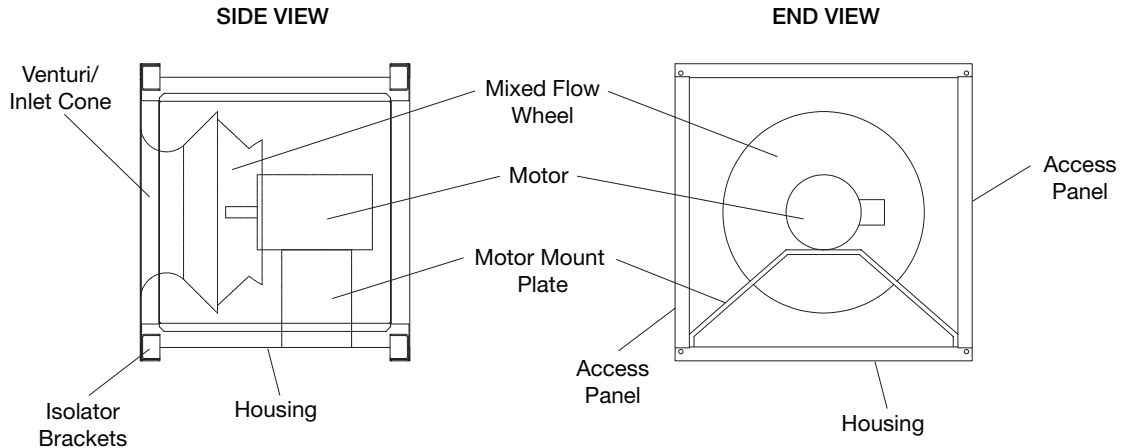

Universal Construction

NOTE: SQ-22 and larger will include the extra motor mount braces shown below.

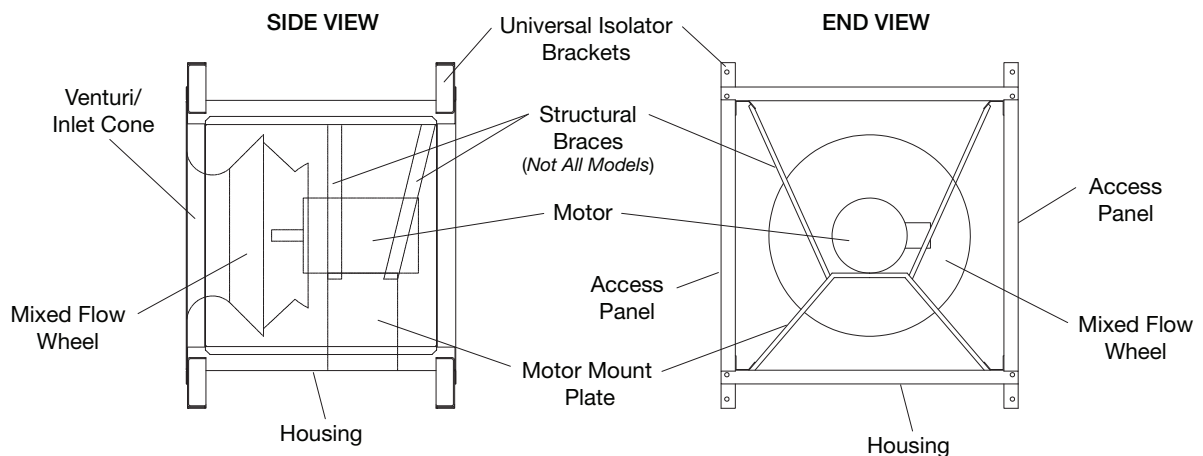

For field installation of universal mount:

1. Disconnect and lock-out all power switches to fan.
2. Place fan on the floor in the horizontal position with the motor directly above the motor mount plate.
3. Use the provided self-rolling screws to fasten in the four extra braces starting with the vertical ones that fasten to the motor mount plate closest to the wheel.
4. Fasten in the last two braces that mount on the air discharge side of the motor mount plate and are angled to the top corners or the discharge outlet.
NOTE: One brace may not be used if the brace interferes with the motor junction box.
5. Remove the standard isolator brackets and replace with the universal isolator brackets provided.

Our Commitment

As a result of our commitment to continuous improvement, Greenheck reserves the right to change specifications without notice.

Product warranties can be found online at Greenheck.com, either on the specific product page or in the literature section of the website at Greenheck.com/Resources/Library/Literature.

AMCA Publication 410-96, Safety Practices for Users and Installers of Industrial and Commercial Fans, provides additional safety information. This publication can be obtained from AMCA International, Inc. at www.amca.org.

