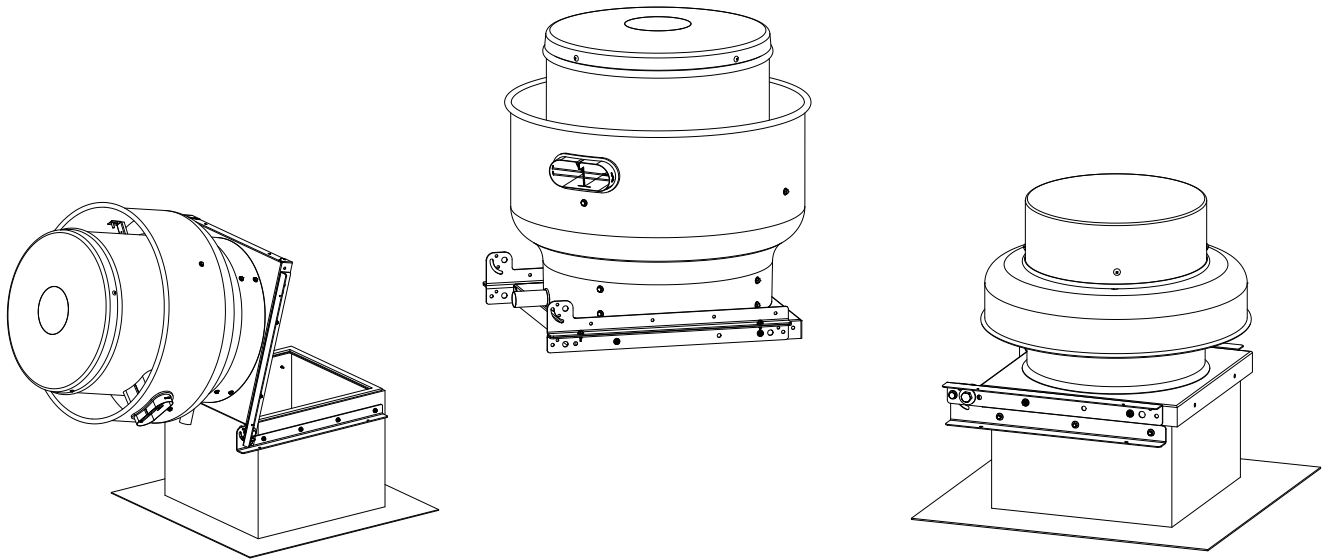


## Installation, Operation and Maintenance Manual

Please read and save these instructions for future reference. Read carefully before attempting to assemble, install, operate or maintain the product described. Protect yourself and others by observing all safety information. Failure to comply with these instructions will result in voiding of the product warranty and may result in personal injury and/or property damage.



### Recommended tools for installation

- Two 3/4 inch wrenches or hex sockets
- Two 1/2 inch wrenches or hex sockets
- 5/16 inch hex driver bit
- Tape
- Marker

### WARNING

Disconnect power and observe proper lockout tagout procedures per OSHA Regulation, Title 29 Code of Federal Regulations Part 1910.147 & 1910.333.

### NOTE

If fan is connected to electrical source via rigid connection, a qualified electrician will need to change the rigid connection to a flexible connection long enough per local electrical codes to allow for fan movement.

### Included Fasteners

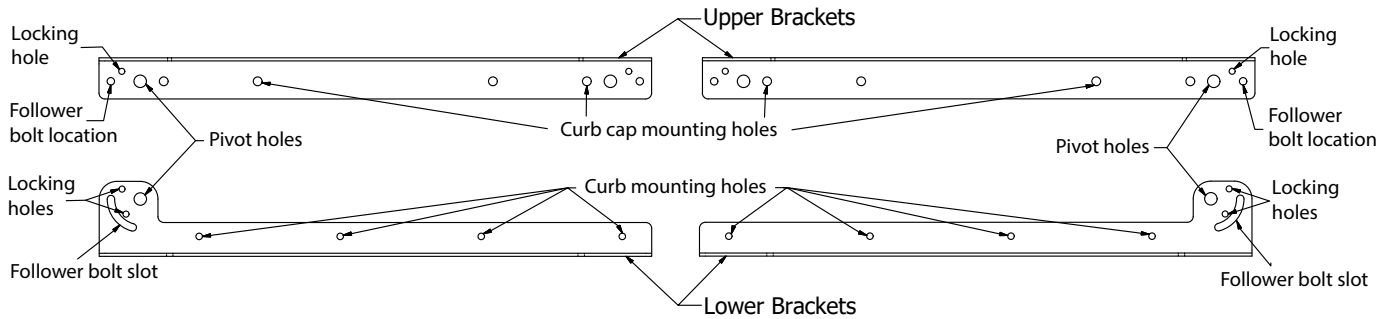
Qty	Description	Part Number
2	1/2" - 13 x 2.5" bolt	415273
2	1/2" - 13 lock nut	415269
20	1/2" flat washer	415080
2	5/16" - 18 x 2 shoulder bolt	415985
2	5/16" - 18 lock nut	415240
22	5/16" flat washer	415082
12	#12 x 1" L self-drilling screw w/ clima seal	415450
4	5/16" - 18 x 0.75" weld stud	415160
4	5/16" - 18 serrated flange nut	415456
2	1/4" dia quick release detent pin*	417565
2	1/4" - 20 x 2.5" shoulder bolt*	415527
2	1/4" - 20 flanged nut*	415455

\* Depending on hinge kit ordered, may receive either detent pins or shoulder bolts and nuts.

### NOTE

There may be extra self-drilling screws remaining after kit is assembled, this will depend on fan size.  
Factory mounted kits will have extra weld studs and flange nuts after kit assembled.

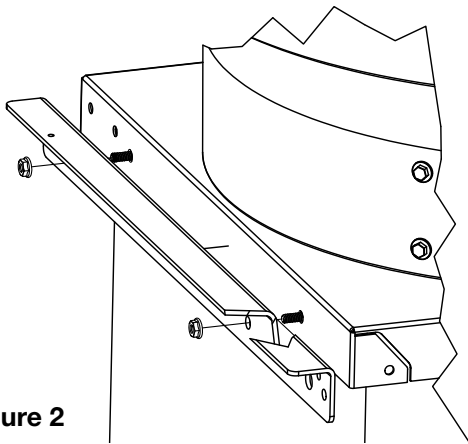
## Installation (Rooftop 060 - 200, Sidewall 060 - 160)



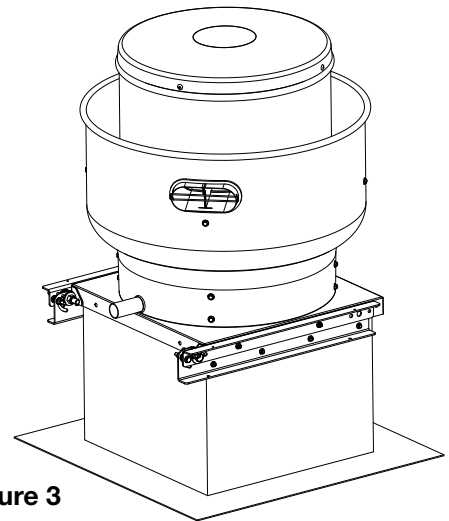
**Figure 1**

1. If fan was ordered as Factory Mounted, skip to step 3, otherwise locate two upper brackets and two lower brackets. See Figure 1.
2. Fasten the upper brackets to each side of the curb cap using two 5/16" - 18 x 3/4" weld studs and two flange nuts per bracket. It may help to place the fan on top of the roof curb offset 45 degrees as to how it should sit, this will allow for easier access to the curb cap holes. See Figure 2.

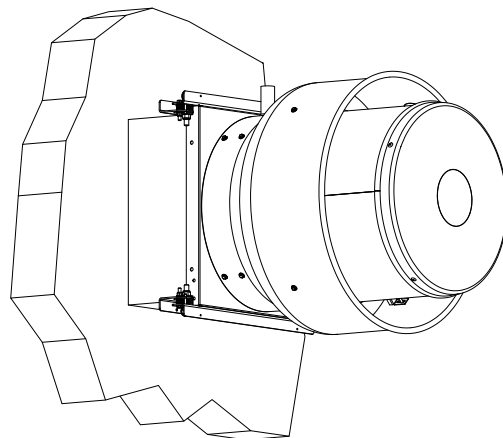
**NOTE:** If installing bracket hinge kit on a **rooftop** upblast fan (Figure 3), ensure the pivot portion of the upper bracket that extends beyond the curb cap is on the side of the grease trough/drain. If installing bracket hinge kit on a **sidewall** upblast fan (Figure 4), completely install hinges before mounting curb to wall and remove before curb installation on or through the wall. Ensure the grease trough/drain will point downward and the upper brackets are installed to open the fan outward.



**Figure 2**

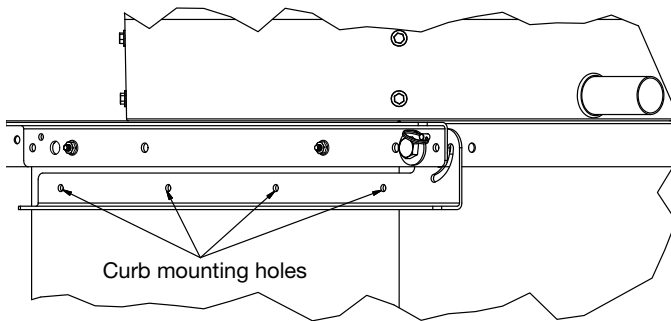


**Figure 3**



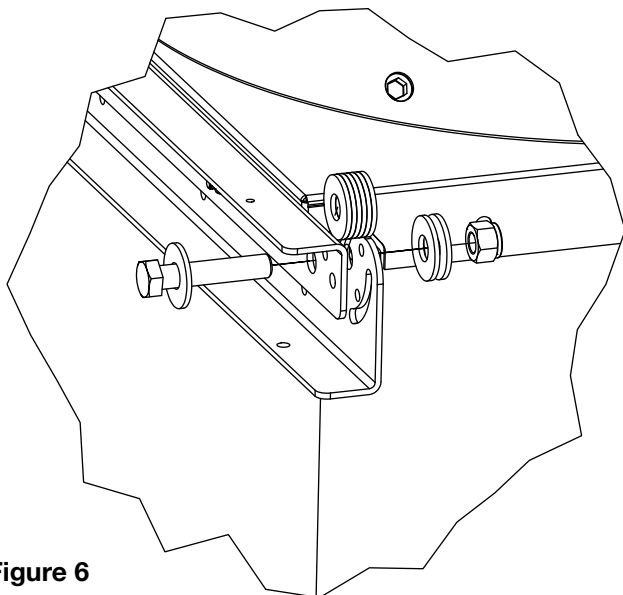
**Figure 4**

3. Place fan squarely onto roof curb maintaining even spacing on each side between the curb and curb cap.
4. If hinge was ordered as Factory Mounted, remove the self-drilling screws that fasten the lower bracket to its respective upper bracket, 2 screws per bracket. If kit was shipped loose, locate left and right lower brackets to their respective side.
5. Insert the 1/2" bolt into the pivot hole of an upper bracket and its respective lower bracket. Also inset the detent pin or 1/4" shoulder bolt into locking hole in the upper bracket and lower locking hole of the lower bracket. While pressing the lower bracket against the roof curb and holding it level, mark the curb mounting holes using a marker. See Figure 5.
8. Tighten the 1/2" - 13 lock nut onto the 1/2" - 13 x 2.5" shoulder bolt until the bolt can still rotate using a wrench. Do not over tighten or hinge may bind and not function properly.
9. In similar fashion to step 7, install the 5/16" - 18 x 2" shoulder bolt and washers into the follower bolt hole and follower bolt slot as shown in Figure 7. After determining the amount of 5/16" flat washers needed to act as a spacer it may help to tape them together for installation. Remove the tape after installation if this method is used.

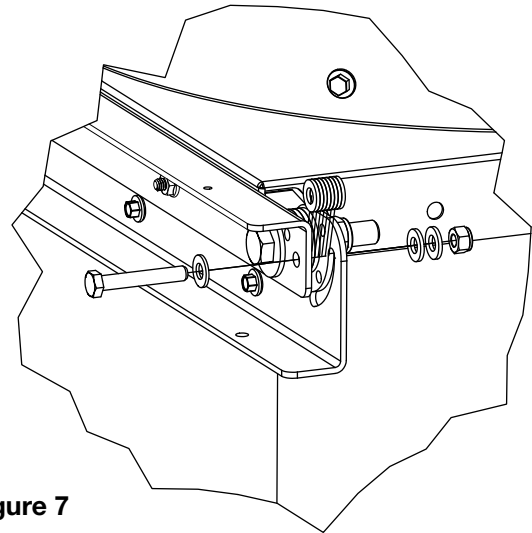


**Figure 5**

6. Install the appropriate amount of self-drilling screws into the lower bracket using a 5/16" driver, the quantity of screws varies depending on fan size.
7. Determine how many 1/2" flat washers are needed between the upper and lower bracket pivot points and install the 1/2" - 13 x 2.5" bolt and washers as shown in Figure 6. The number of washers needed will vary depending on curb undersizing.

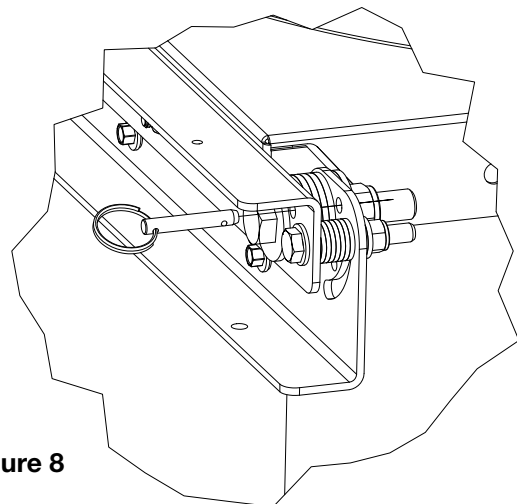


**Figure 6**



**Figure 7**

10. Tighten the 5/16" - 18 lock nut onto the 5/16" - 18 x 2" shoulder bolt until the bolt can still rotate using a wrench. Do not overtighten this bolt or hinge may bind and not function properly.
11. Repeat steps 5 through 10 for mounting lower bracket on the opposite side.
12. To lock hinge in closed position, insert detent pin or 1/4" - 20 x 2 1/2" should bolt and flange nut through the locking hole of the upper bracket and into the top locking hole of the lower bracket as shown in Figure 8. In a sidewall mounted unit, it is good practice to secure the unit closed either with self-drilling screws through the curb cap flange holes and into the curb or by installing a latch kit.



**Figure 8**

13. To lock hinge in open position, insert detent pin or 1/4" - 20 x 2 1/2" shoulder bolt and flange nut through the locking hole of the upper bracket and into the bottom locking hole of the lower bracket as shown in Figure 9.

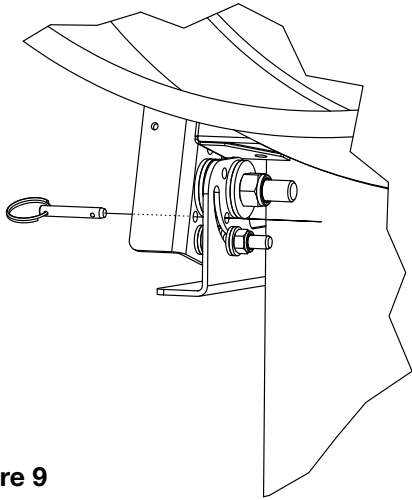


Figure 9

**WARNING**

When hinging fan open, detent pins or lock bolts must be inserted in the lock-hole position and secured to prevent sudden closure.

**CAUTION**

Forcible hinging of fan may result in damage to the fan curb cap. Take caution when hinging fan.

Final assembly view with hinge in hold open position in rooftop and sidewall orientations.

