

Installation, Operation and Maintenance Manual

Please read and save these instructions for future reference. Read carefully before attempting to assemble, install, operate or maintain the product described. Protect yourself and others by observing all safety information. Failure to comply with these instructions will result in voiding of the product warranty and may result in personal injury and/or property damage.

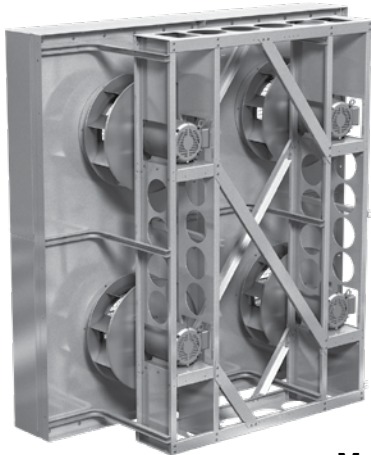

Model OPA

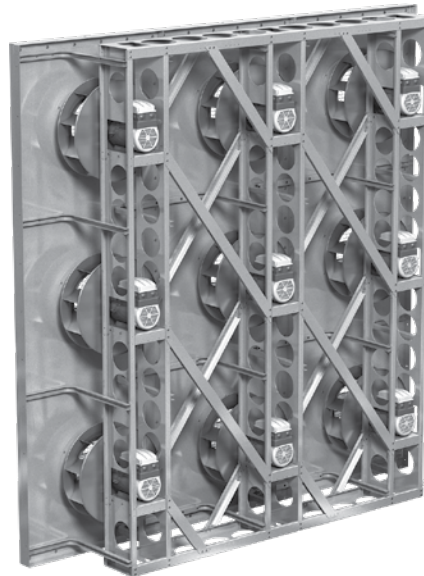

General Safety Information

Only qualified personnel should install this array. Personnel should have a clear understanding of these instructions and should be aware of general safety precautions. Improper installation can result in electric shock, possible injury due to coming in contact with moving parts, as well as other potential hazards. If more information is needed, contact a licensed professional engineer before moving forward.

1. Follow all local electrical and safety codes, as well as the National Electrical Code (NEC), the National Fire Protection Agency (NFPA), where applicable. Follow the Canadian Electric Code (CEC) in Canada.
2. The rotation of the wheel is critical. It must be free to rotate without striking or rubbing any stationary objects.
3. Motor must be securely and adequately grounded.
4. Do not spin the wheel faster than max cataloged RPM. Adjustments to fan speed significantly effects motor load. If the fan RPM is changed, the motor current should be checked to make sure it is not exceeding the motor nameplate amps.
5. Do not allow the power cable to kink or come in contact with oil, grease, hot surfaces or chemicals. Replace cord immediately if damaged.
6. Verify that the power source is compatible with the equipment.

DANGER

Always disconnect, lock and tag power source before installing or servicing. Failure to disconnect power source can result in fire, shock or serious injury.

CAUTION

When servicing the fan, motor may be hot enough to cause pain or injury. Allow motor to cool before servicing.

CAUTION

Precaution should be taken in explosive atmospheres.

DANGER

Pour écarter les risques d'incendie, de choc électrique ou de blessure grave, veiller à toujours débrancher, verrouiller et étiqueter la source de courant avant l'installation ou l'entretien.

ATTENTION

Lors de toute intervention sur la soufflante, le moteur peut être suffisamment chaud pour provoquer une douleur voire une blessure. Laisser le moteur refroidir avant toute maintenance.

ATTENTION

Faire preuve de précaution dans les atmosphères explosives.

Receiving

Upon receiving the product check to ensure all items are accounted for by referencing the delivery receipt or packing list. Inspect each crate or carton for shipping damage before accepting delivery. Alert the carrier of any damage detected. The customer will make a notation of damage (or shortage of items) on the delivery receipt and all copies of the bill of lading which is countersigned by the delivering carrier. If damaged, immediately contact the local sales representative. Any physical damage to the unit after acceptance is not the responsibility of the manufacturer.

Unpacking

Verify that all required parts and the correct quantity of each item have been received. If any items are missing report shortages to arrange for obtaining missing parts. Sometimes it is not possible that all items for the unit be shipped together due to availability of transportation and truck space. Confirmation of shipment(s) must be limited to only items on the bill of lading.

Handling

Arrays are to be rigged and moved by the lifting brackets provided or by the skid when a forklift is used. Location of brackets varies by model and size. Eight-foot extended forks are required. Handle in such a manner as to keep from scratching or chipping the coating. Damaged arrays may reduce the ability of the fan to resist corrosion. Arrays should never be lifted by the shaft, motor, damper, inlet or outlet guard or accessories.

Storage

- Do not store outdoors
- Rotate the wheel monthly
- Energize the motor once every three months
- Store unit in location which does not have vibration

If storage of fan is in a humid, dusty or corrosive atmosphere, rotate the fan once a month. Improper storage which results in damage to the array will void the warranty.

Arrays are protected against damage during shipment. If the unit cannot be installed and operated immediately, precautions need to be taken to prevent deterioration of the unit during storage. The user assumes responsibility of the fan and accessories while in storage. The manufacturer will not be responsible for damage during storage. These suggestions are provided solely as a convenience to the user.

The ideal environment for the storage of the array and accessories is indoors, above grade, in a low humidity atmosphere which is sealed to prevent the entry of blowing dust, rain, or snow. Temperatures should be evenly maintained between 30°F (-1°C) and 110°F (43°C) (wide temperature swings may

cause condensation and “sweating” of metal parts). All accessories must be stored indoors in a clean, dry atmosphere.

Remove any accumulations of dirt or debris and wipe clean before moving to indoor storage. To avoid “sweating” of metal parts, allow cold parts to reach room temperature. To dry parts and packages use a portable electric heater to get rid of any moisture build up. Leave coverings loose to permit air circulation and to allow for periodic inspection.

The unit should be stored at least 3-1/2 in. (89 mm) off the floor on wooden blocks covered with moisture proof paper or polyethylene sheathing. Aisles between parts and along all walls should be provided to permit air circulation and space for inspection.

Inspection & Maintenance during Storage

While in storage, inspect array once per month. Keep a record of inspection and maintenance performed.

If moisture or dirt accumulations are found on parts, the source should be located and eliminated. At each inspection, rotate the wheel by hand ten to fifteen revolutions to distribute lubricant on motor.

Machined parts coated with rust preventive should be restored to good condition promptly if signs of rust occur. Immediately remove the original rust preventive coating with petroleum solvent and clean with lint-free cloths. Polish any remaining rust from surface with crocus cloth or fine emery paper and oil. Do not destroy the continuity of the surfaces. Wipe clean thoroughly with Tectyl® 506 (Ashland Inc.) or the equivalent. For hard to reach internal surfaces or for occasional use, consider using Tectyl® 511M Rust Preventive or WD-40® or the equivalent.

Removing from Storage

As the arrays are removed from storage to be installed in their final location, they should be protected and maintained in a similar fashion, until the fan equipment goes into operation.

Prior to fully assembling and installing the array and system components, inspect the array assembly to make sure it is in working order.

1. Check all fasteners, set screws, wheel, motors and accessories for tightness.
2. Rotate the wheel by hand and assure no parts are rubbing.
3. Ensure proper wheel settings for radial gap and alignment. See page 6.

General Information

To ensure a successful installation, the instructions in this manual should be read and adhered to. Failure to comply with proper installation procedures may void the warranty.

Unit and System Identification Tags

Each array has a permanently affixed manufacturer's engraved metal nameplate containing the model number and individual serial number.

The tag shown is an example of an identification nameplate on the array. The information provides general details about the fan, as well as containing specific information unique to the unit. When contacting the local sales representative with future needs or questions, please have the information on this label available. Tags are mounted in an area which is clearly visible, usually on the side of the fan array.

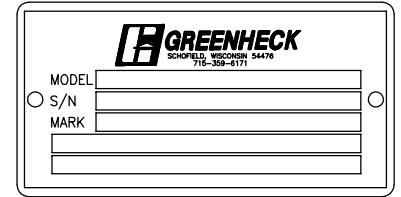

Pre-Installation Information

Before installation, it is important to be certain the mounting surface will bear the operating weight of the unit. For proper unit operation, it is also important that it be operated in a completely level position. Leveling shims may be required for proper installation. See next page.

For further details on safety practices involving industrial and commercial fans, please refer to AMCA Publication 410.

Moving Parts

All moving parts must have guards to protect personnel. Refer to local codes for requirements as to the number, type and design. Fully secure the wheel before performing any maintenance. The wheel may start "free wheeling" even if all electrical power has been disconnected. Before the initial start-up or any restart, check the following items to make sure that they are installed and secure.

- Do not spin the wheel faster than the maximum cataloged fan RPM.
- Adjustments to fan speed significantly affects motor load. If the fan RPM is changed, the motor current should be checked to make sure it is not exceeding the motor nameplate amps.

Air Pressure and Suction

In addition to the usual hazards associated with rotating machinery, arrays also create a dangerous suction at the inlet. Special caution needs to be used when moving around an array, whether it is in operation or not. Before start-up, make sure the inlet area is clear of personnel and loose objects.

Rigging and Lifting

CAUTION

Arrays should never be lifted by the shaft, motor, guards or accessories.

Arrays are to be rigged and moved by the lifting brackets and/or lifting points provided or by the skid when a forklift is used. Handle in such a manner as to keep from scratching or denting. Damage may reduce the ability of array to resist corrosion.

- Use standard lifting and rigging practices. Use of a spreader bar is recommended.
- **ALL** lifting brackets on each component must be utilized at the same time.

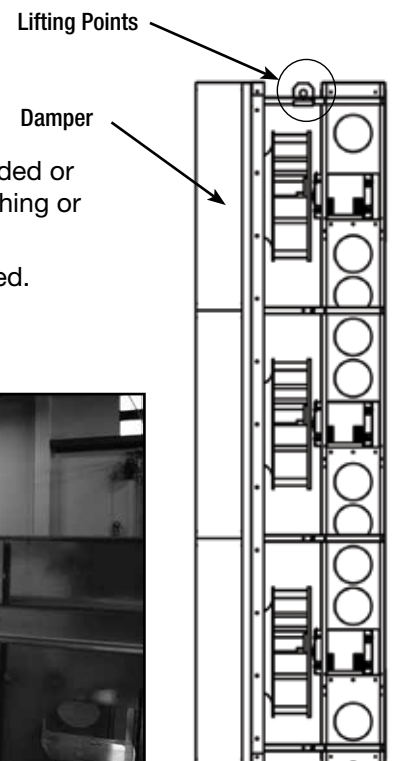

Installation

1. Carefully remove any crate and packing materials.
2. Array ships from factory fully assembled unless width exceeds 12 feet. If greater than 12 ft wide, multiple sections are to be assembled at the job site. Lift each section into place and secure to one another.
3. Leveling and Shimming
Use slotted shim stock beneath the bottom array as needed. Spaces greater than 0.025 in. (0.635 mm) should be shimmed.
4. Place the array onto the mounting structure using the recommended lifting points and hooking method as shown. Anchor frame to floor using all anchor points shown above. The array also requires anchoring to the walls and ceiling, see above illustration for details. (Anchoring material provided by installer).

Example of Shim Stock

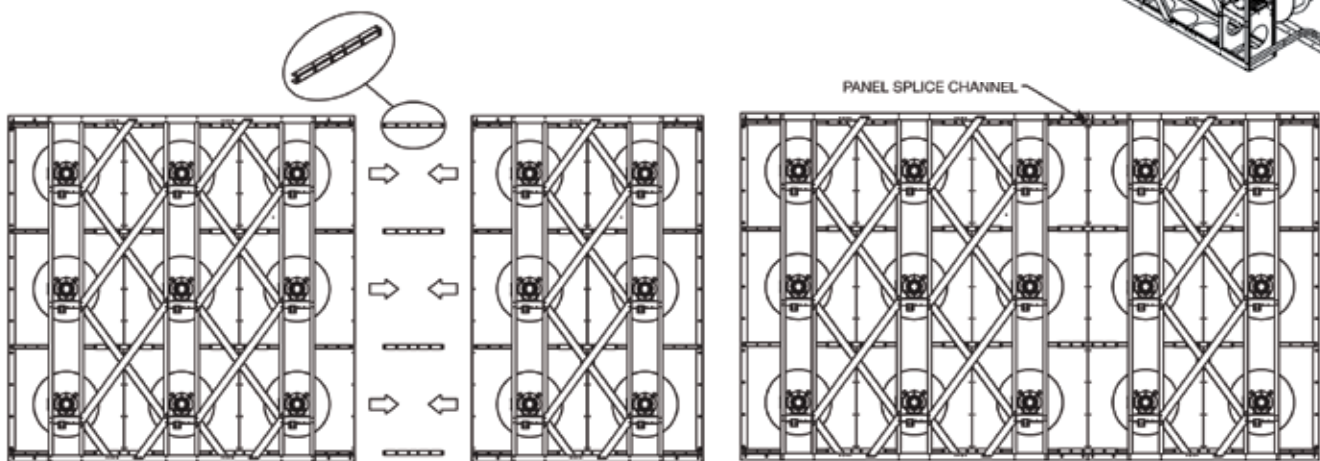
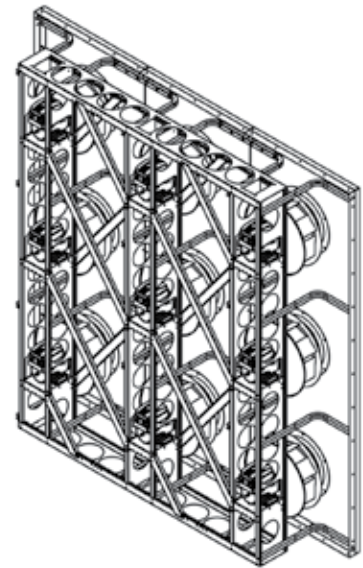

5. Wiring to be provided by others. All supply and/or signal wiring should be secured to the array structure.

CAUTION

When installing an array, ensure the proper protective devices are used to protect personnel from moving parts and other hazards. A complete line of protective accessories are available from the manufacturer.

Electrical Connections

Before electrical connections are made, the supply voltage, phase and ampere capacity must be checked for compatibility with the fan motor. In addition, the supply wiring must be properly fused and conform to local and national electrical codes. If the unit is supplied with a safety disconnect switch, ensure proper wiring to the fan motor. Be sure the disconnect is switched to the "OFF" position before connecting supply wires. If no disconnect is supplied, ensure the supply wire is not live before connection. Supply wires are then connected to the optional safety disconnect switch (if supplied) or motor.

Radial Gap, Overlap and Wheel Alignment

Efficient array performance can be maintained by having the correct radial gap, overlap and wheel alignment. These items should be checked after the array has been in operation for 24 hours and before start-up after the unit has been serviced.

Overlap, or offset, is adjusted by loosening the wheel hub from the shaft and moving the wheel to the desired position along the motor shaft. The transition between the inlet cone and wheel should be as shown; there is a smooth feel to the profile when moving from one component to the other.

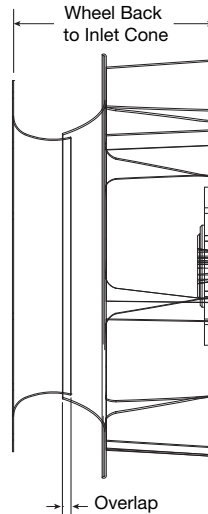

Backward Curved Aluminum Wheel (Mill Finish)				
Unit Size	Overlap		Overall Assembly Wheel Back to Inlet Cone	
	inch	mm	inch	mm
315	0.12	3.2	7.26	184
355	0.14	3.6	8.17	208
400	0.16	4.0	9.09	231
450	0.18	4.5	10.19	259
500	0.20	5.0	11.32	288
560	0.22	5.6	12.80	325
630	0.25	6.3	14.49	368

Airfoil Aluminum Wheel (Mill Finish)				
Unit Size	Overlap		Overall Assembly Wheel Back to Inlet Cone	
	inch	mm	inch	mm
315	0.12	3.2	7.43	189
355	0.14	3.6	8.43	214
400	0.16	4.0	9.40	239
450	0.18	4.5	10.58	269
500	0.20	5.0	11.71	298
560	0.22	5.6	13.11	333
630	0.25	6.3	14.84	377

Wheel Removal / Installation

Taper-Lock Bushing Installation & Removal

To Install Taper-Lock™ Bushings:

1. Clean shaft, bore and outside of bushing, and bore of hub (taking bushings from hub if already assembled). Remove any oil, grease and dirt.
2. Place hub onto shaft. Slip bushing onto shaft and into hub. Oil threads and points of setscrews or threads and under heads of capscrews. **DO NOT** lubricate the hub bore or the outside of the bushing. Place screws loosely in holes that are threaded on hub side (shown as  on diagram above).
3. Locate assembly in desired position and tighten screws slightly to seat bushing in hub.
4. Tighten screws alternately and evenly to the fastener torque. Do not overtorque. Using a hammer and drift, hammer against large end of bushing. Hammer first beside the screw farthest from the bushing split and then hammer on the bushing on the opposite side of the screw. Avoid hammering close to the OD of the bushing to prevent damage. Working towards the split, hammer on the bushing on each side of the setscrews. Then hammer on each side of the bushing split. Make sure that the surfaces back both sides of the split are even. Screws can now be tightened to fastener torque. Repeat sequence, hammering and retightening until the specified fastener torque no longer turns the screws after hammering.

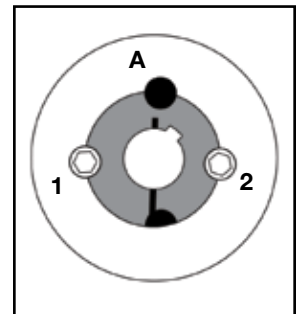

WARNING

DO NOT use lubricants on the bushing body or hub bore.

Wheel Removal / Installation (Continued)

To Remove:

1. Remove all screws. Oil threads and points of set screws or threads and under heads of cap screws.
2. Insert screws into holes that are threaded on the bushing side (shown as  on image). In sizes where washers are found under the screw heads, be sure to use the washers. Note that one screw in each hub is leftover and is not used in the loosening operation.
3. Tighten screws alternately until bushing is loosened in hub. If bushing does not loosen, tap on face of hub.

Backward Curved Aluminum Wheel (Mill Finish)			
Unit Size	TaperLock Bushing	Fastener Torque	Screws
		lb-ft	
315	SM12/BF16	15	3/8
355	SM12/BF16	15	3/8
400	SM12	15	3/8
450	SM12	15	3/8
500	SM20	22	7/16
560	SM20	22	7/16
630	SM20	22	7/16

Airfoil Aluminum Wheel (Mill Finish)			
Unit Size	TaperLock Bushing	Fastener Torque	Screws
		lb-ft	
315	BF16	15	3/8
355	BF16	15	3/8
400	SM16	15	3/8
450	SM16	15	3/8
500	SM20	22	7/16
560	SM25	39	1/2
630	SM25	39	1/2

Unit Start-Up

WARNING

Disconnect and secure to the "Off" position all electrical power to the array prior to inspection or servicing. Failure to comply with this safety precaution could result in serious injury or death.

Visual Inspection of Equipment

The equipment type and arrangement should be verified as ordered at once when it arrives at the jobsite. When a discrepancy is found, the local sales representative must be notified immediately so that corrective action may be investigated, also verify electrical conformance to specifications. Unauthorized alterations and unauthorized backcharges will not be recognized by the manufacturer.

After the array has been assembled, installed and all utilities have been hooked up, the unit is now ready for operation.

Check

Before starting the array, check the following:

1. Confirm that building supply voltage matches the voltage for which the unit is wired.
2. Disconnect and lock-out all power switches to array. See warning below.
3. Check all piping and wiring penetrations made by contractors for water tightness. All penetrations must be made watertight to prevent water damage to the unit and building.
4. Check all fasteners, set screws and locking collars on the array, bearings, drive, motor base and accessories for tightness.
5. Rotate the wheel by hand and assure no parts are rubbing. Remove any dirt or debris that may have accumulated during installation.
6. Check all guarding (if supplied) for being securely attached and not interfering with rotating parts.
7. Check all electrical connections for proper attachment.
8. Check for obstructions and foreign material that may damage the wheel.

Additional Steps for Initial Start-Up

1. Check for proper wheel rotation by momentarily energizing the fan. Rotation is always determined by viewing the wheel from the drive side and should correspond to the rotation decal affixed to the unit.

Note: One of the most frequently encountered problems with centrifugal fans is motors which are wired to run in the wrong direction. This is especially true with 3-phase installations where the motor will run in either direction, depending on how it has been wired. To reverse rotation of a 3-phase motor, interchange any two of the three electrical leads. Single phase motors can be reversed by changing internal connections as described on the motor label or wiring diagram.

2. Arrays with multi-speed motors should be checked on low speed during initial start-up.
3. Check for unusual noise, vibration or overheating of bearings. Refer to the “Troubleshooting” section of this manual if a problem develops.

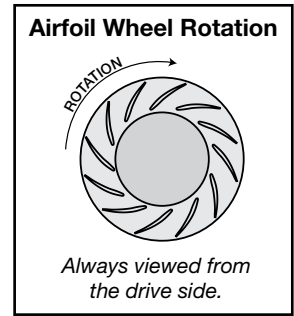

Routine Maintenance

CAUTION

When performing any service to the array, disconnect the electrical supply and secure wheel.

Once the unit has been put into operation, a routine maintenance schedule should be set up to accomplish the following:

1. Wheel, motor bolts and set screws on the entire fan should be checked for tightness.
2. Any dirt accumulation on the wheel or in the housing should be removed to prevent unbalance and possible damage.
3. Inspect fan wheel and motor, looking for fatigue, corrosion, or wear.

When performing any service to the unit, disconnect the electrical supply and secure array wheel.

Operation

All arrays should be run every thirty (30) days, or at least “bumped” every thirty days. It is preferred that each array is run as this causes all electrical and mechanical components to get up to temperature, displacing any formed condensation, redistributes load on bearings, and redistributes grease in the bearings (motor and shaft bearings).

Vibration

Excessive vibration is the most frequent problem experienced during initial start-up.

Left unchecked, excessive vibration can cause a multitude of problems, including structural and/or component failure.

Common Sources of Vibration

1. Wheel Unbalance
2. Bearing
3. Mechanical Looseness
4. Drive Component Unbalance
5. Poor Inlet/Outlet Conditions
6. Foundation Stiffness

Many of these conditions can be discovered by careful observation. Refer to the troubleshooting section of this manual for corrective actions. If observation cannot

locate the source of vibration, a qualified technician using vibration analysis equipment should be consulted. If the problem is wheel unbalance, in-place balancing can be done providing there is access to the fan wheel. Any correction weights added to the wheel should be attached securely.

The factory performs a vibration test on all each array fan individually. Vibration readings are taken on each array fan in the horizontal, vertical, and axial directions.

These vibration signatures are a permanent record of how the fan left the factory and are available upon request.

CAUTION

- Always check the fan RPM when adjusting the operating frequency. Do not exceed maximum class fan RPM of the wheel.
- When operating conditions of the array are to be changed (speed, pressure, temperature, etc.), consult the factory to determine if the unit can operate safely at the new conditions.

Troubleshooting

Problem	Cause	Corrective Action
Excessive Noise	Wheel rubbing (inlet)	Adjust wheel and/or inlet cone. Tighten wheel hub or bearing collars on shaft.
	Wheel unbalance	Clean all dirt off wheel. Check wheel balance, rebalance in place if necessary.
Low CFM	Fan	Check wheel for correct rotation. Increase fan speed.*
	Duct system	Check duct installations with poor inlet or discharge configurations.
High CFM	Fan	Decrease fan speed.
High Horsepower	Fan	Check rotation of wheel. Reduce fan speed.
Fan Doesn't Operate	Electrical supply	Check fuses/circuit breakers. Check for switches turned off or disconnected. Check for correct supply voltage.
	Motor	Assure motor is correct horsepower and not tripping overload protector.
Excessive Vibration	System unbalance	Check wheel balance, rebalance if necessary.

*Always check motor amps and compare to nameplate rating. Excessive fan speed may overload the motor and result in motor failure. Do not exceed the maximum cataloged RPM of the fan.

NOTE: Always provide the unit model and serial numbers when requesting parts or service information.

Parts List

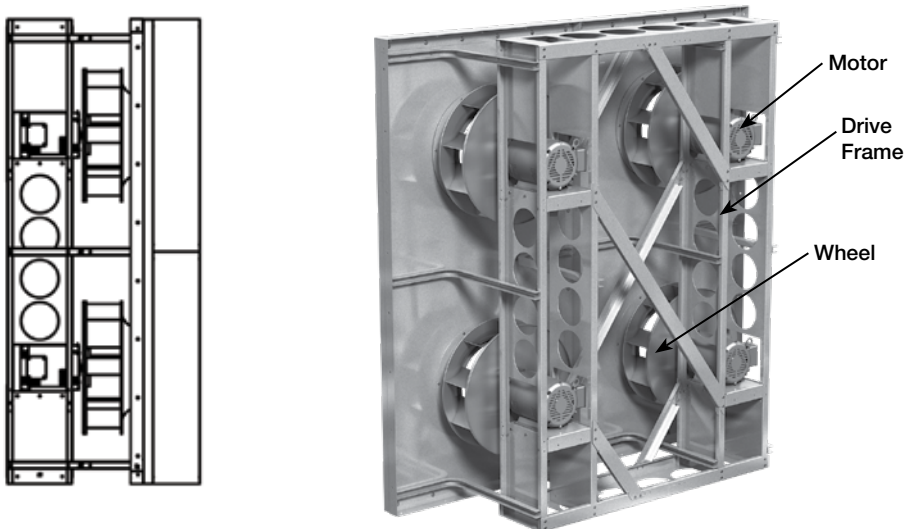

Our Commitment

As a result of our commitment to continuous improvement, Greenheck reserves the right to change specifications without notice.

Product warranties can be found online at Greenheck.com, either on the specific product page or in the literature section of the website at Greenheck.com/Resources/Library/Literature.

AMCA Publication 410-96, Safety Practices for Users and Installers of Industrial and Commercial Fans, provides additional safety information. This publication can be obtained from AMCA International, Inc. at www.amca.org.



Phone: 715.359.6171 • Fax: 715.355.2399 • Parts: 800.355.5354 • E-mail: gfcinfo@greenheck.com • Website: www.greenheck.com