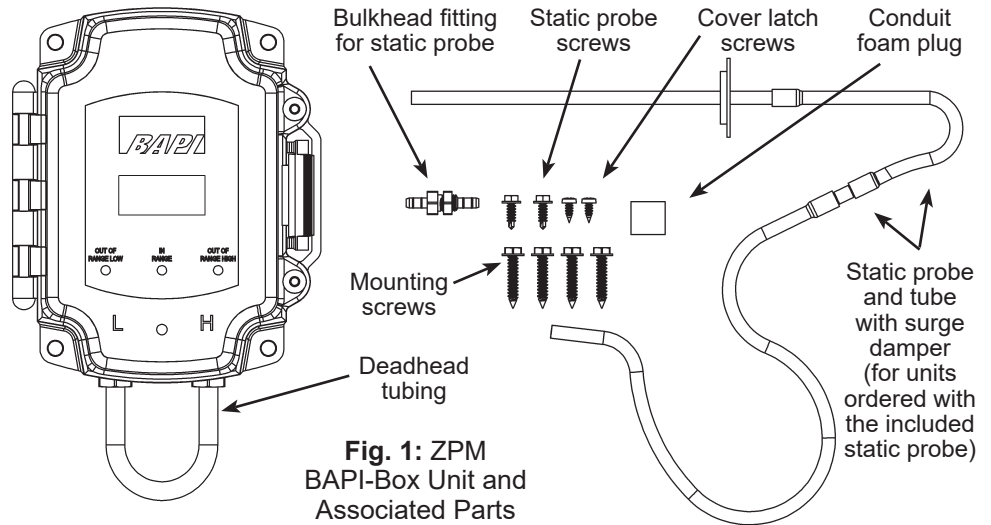


## Identification and Overview

BAPI's ZPM is designed for quick and easy field installation. The outputs, ranges, units, directionality, and response time are quickly set in the field with no tools, no power and no small components.

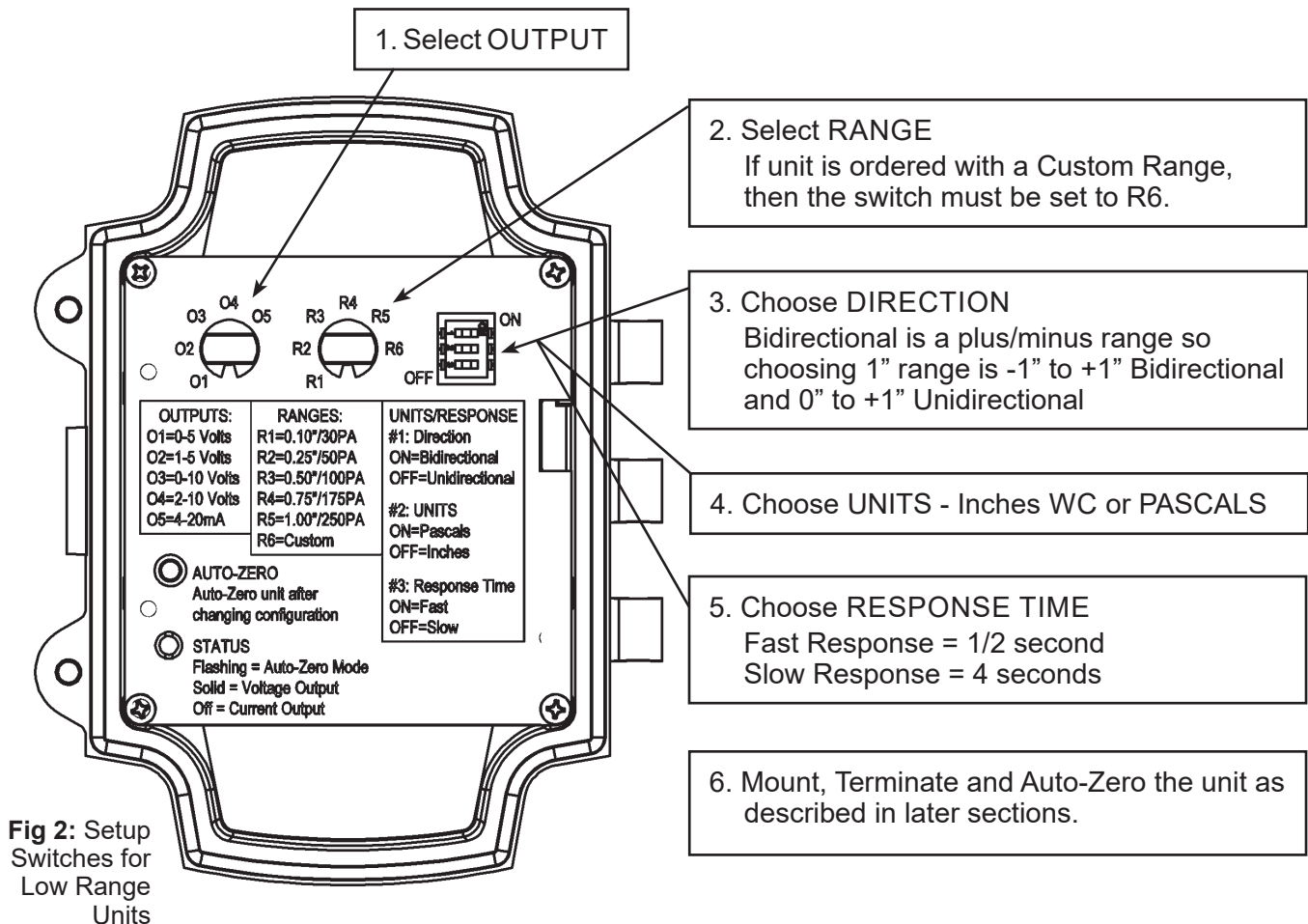
The optional LCD display helps with troubleshooting because it displays the actual pressure regardless of the selected pressure range. Three LEDs on the face of the unit indicate when the pressure is "Out of Range Low", "In Range" or "Out of Range High" for the selected range. The appropriate LED will flash when out of range.



**Fig. 1:** ZPM BAPI-Box Unit and Associated Parts

## Switch Setup - Outputs, Ranges, Units/Response

**NOTE!** Always follow the Auto-Zero procedure after changing settings.



**Fig 2:** Setup Switches for Low Range Units



# Low Range ZPM - Zone Pressure Sensor in a BAPI-Box Enclosure

Installation & Operations

47139\_ins\_ZPM\_LR\_BB

rev. 05/14/21

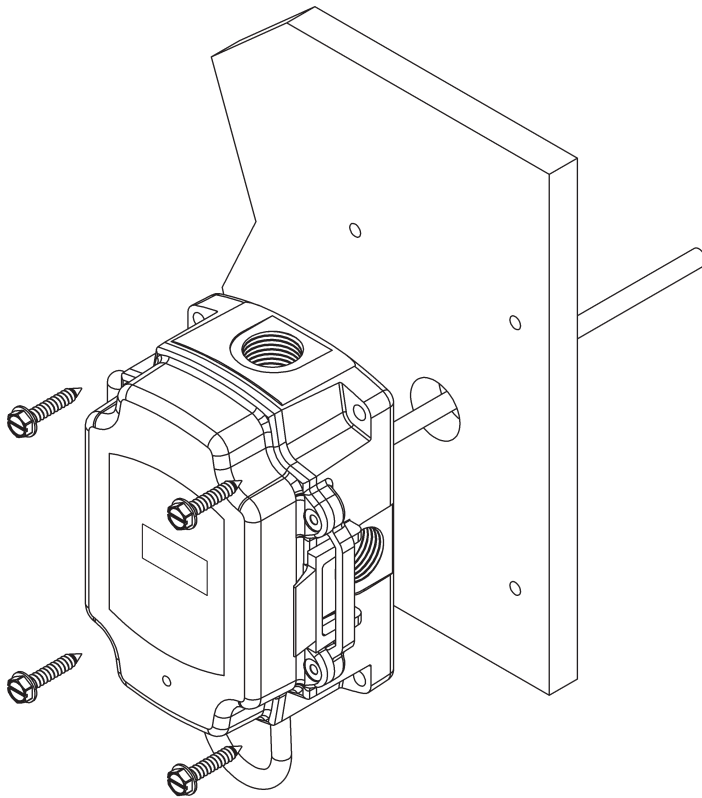
## Mounting

Attach the unit to its mounting surface with the four self-tapping #10x3/4" sheet metal screws through the holes in the mounting feet. The preferred mounting orientation is with the pressure ports facing down.

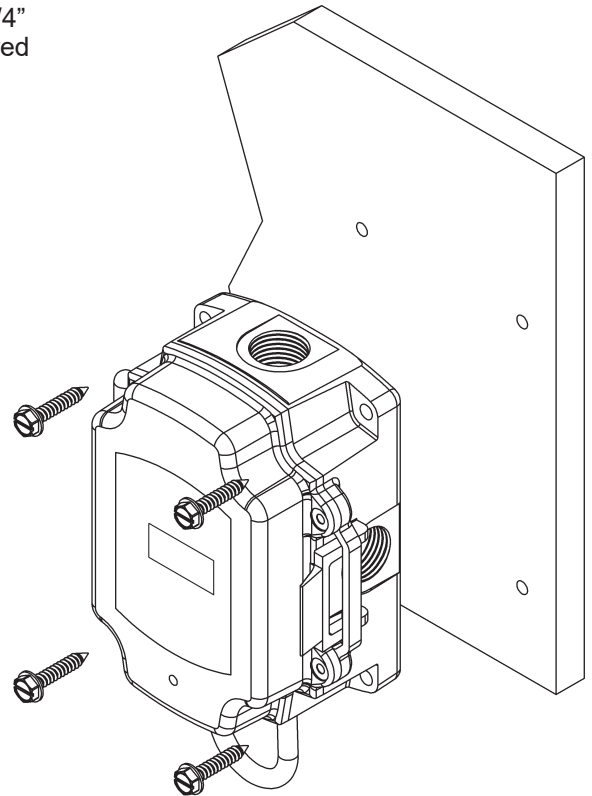
The two cover latch screws must be installed to achieve IP66 rating.

After Auto-Zeroing, remove the deadhead tubing and push the system tubing onto the port nipple without creating any kinks or holes.

See page 3 for an actual size mounting template for the unit.

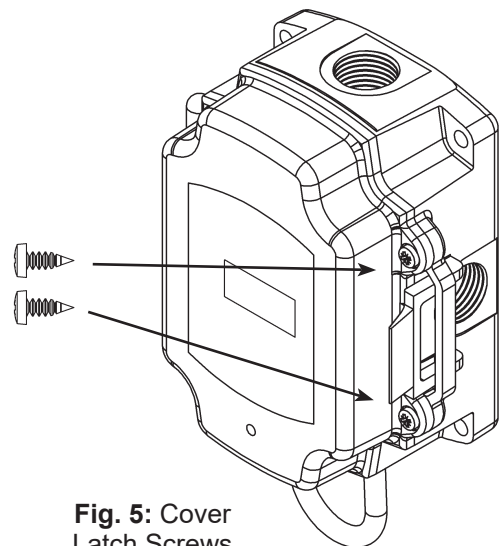


**Fig. 4:** ZPM BAPI-Box Mounting  
(for units with Attached Tube  
option)



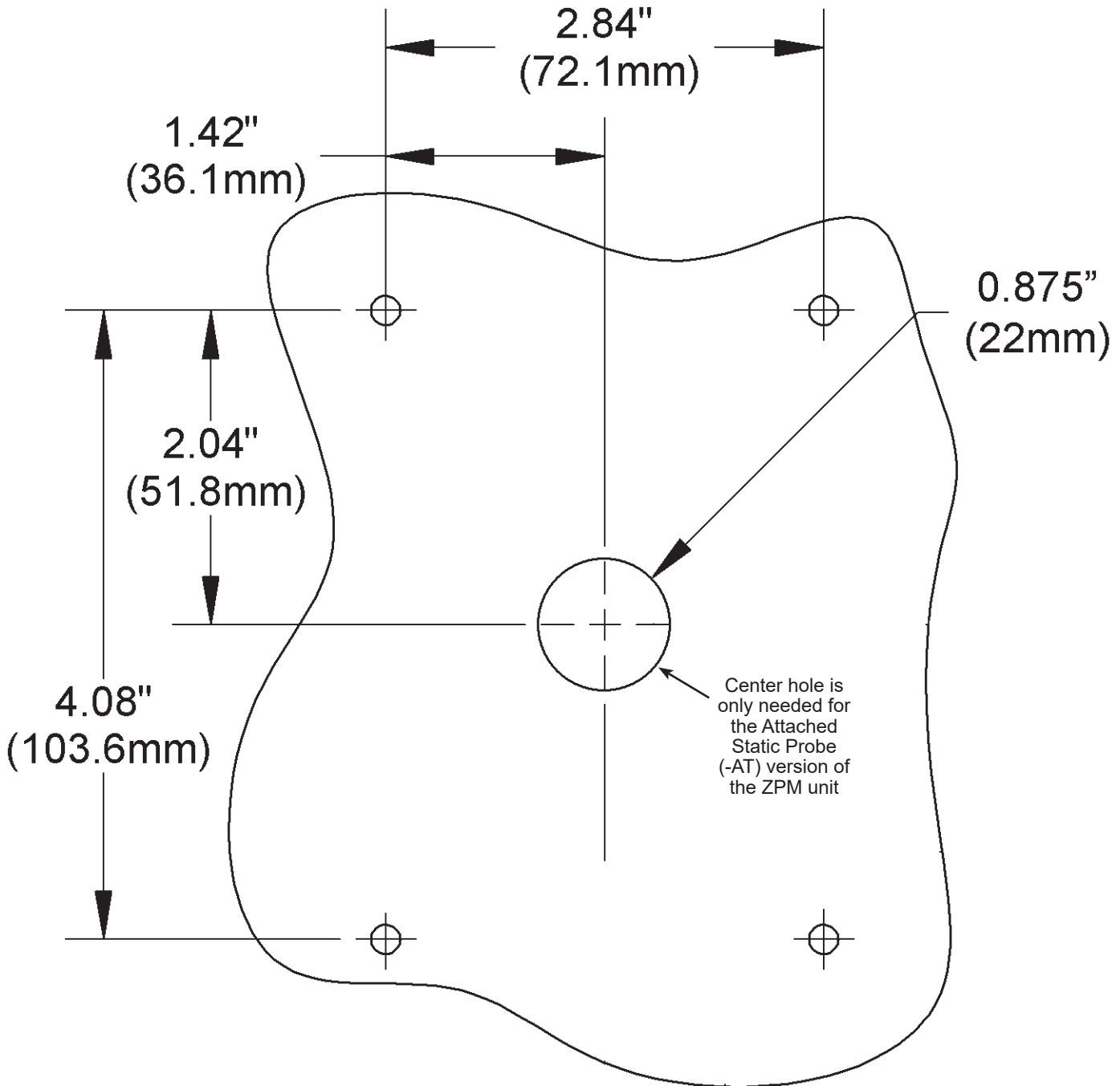
**Fig. 3:** ZPM BAPI-Box Mounting  
(for units without Attached Tube  
option)

Unit includes  
two screws  
for the hinged  
cover



**Fig. 5:** Cover  
Latch Screws

## Mounting Template



**Fig. 6:**  
Mounting Hole Template - shown actual size  
(BAPI recommends creating 5/32" (4mm) pilot holes  
for the #10x3/4" self-tapping mounting screws.)

## Output Termination

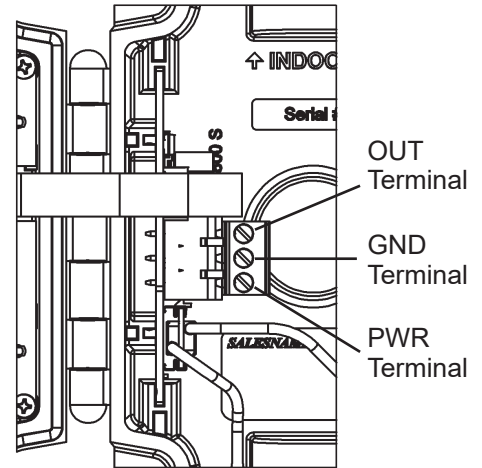


BAPI recommends wiring the product with power disconnected. Proper supply voltage, polarity and wiring connections are important to a successful installation. Not observing these recommendations may damage the product and void the warranty.

To ensure that all wires are properly terminated, twist the stripped ends of each wire together before inserting into the terminals. Gently tug on the wire after inserting into the terminal to verify a good connection.

**Table 1: ZPM Termination**

Output Signal	PWR Terminal	GND Terminal	OUT Terminal
4 to 20 mA	7 to 40 VDC	4 to 20 mA Signal To Controller Analog Input	Not Used
0 to 5 or 1 to 5 VDC	7 to 40 VDC or 18 to 32 VAC	To Controller Ground	VDC Signal To Controller Analog Input
0 to 10 or 2 to 10 VDC	13 to 40 VDC or 18 to 32 VAC	To Controller Ground	VDC Signal To Controller Analog Input



**Fig. 7: ZPM Wiring Terminals**

## Auto-Zero and Status LED Operation

### AUTO-ZERO OPERATION

Auto-Zeroing must be done after the initial setup, changing mounting orientation or changing any settings. For most applications, perform an auto-zero whenever it appears that the sensor has drifted. For critical applications, the unit should be zeroed 2-3 times a year.

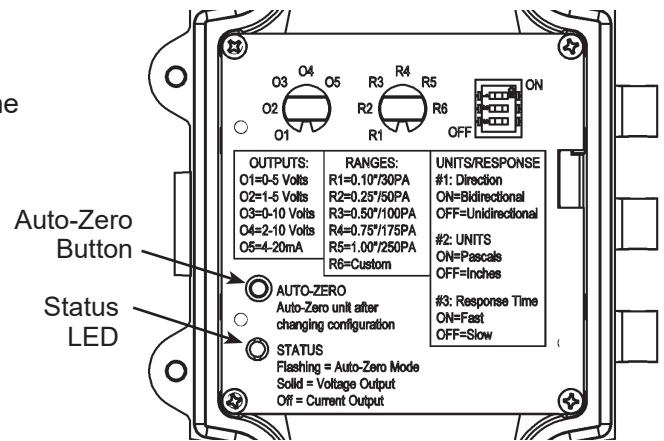
1. Make sure power is applied
2. Detach system tubing and deadhead the ports using the supplied tubing or other short length of tubing. Do not kink the tubing.
3. Press the Auto-Zero button until the Status LED flashes
4. Remove deadhead after the Status LED stops flashing
5. Reattach system tubing

### STATUS LED OPERATION

**LED Off:** No power is applied or the unit is in 4 to 20 mA Mode

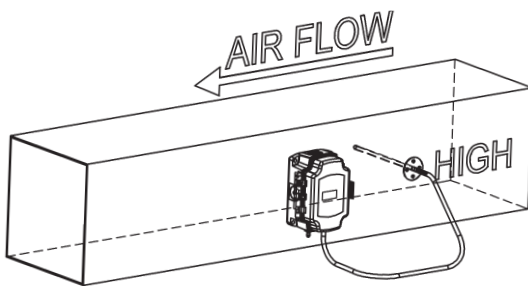
**LED Solid (On):** LED is on when power is applied and a VDC output is selected. When 4 to 20 mA output is selected, the light is on for 2 seconds at power up then goes off.

**LED Flashing:** Auto-Zero. The LED will flash for about 20 seconds.



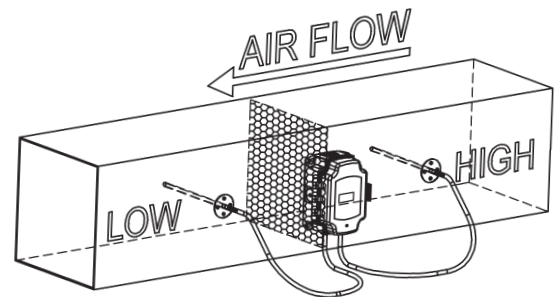
**Fig 8: Auto-Zero Button and Status LED**

## Typical Applications



**Fig. 9: Duct Static Pressure Monitoring**  
(ZPM Pressure Sensor mounted on the duct with a Static Pressure Probe in the duct.)

**NOTE:** Best practice is to form a drip loop in the tubing to prevent condensation from reaching the unit.



**Fig. 10: Air Filter Pressure Drop Monitoring**  
(ZPM Pressure Sensor mounted on the duct with a Static Pressure Probe on either side of the filter in a duct.)



# Low Range ZPM - Zone Pressure Sensor in a BAPI-Box Enclosure

Installation & Operations

47139\_ins\_ZPM\_LR\_BB

rev. 05/14/21

## Diagnostics

### POSSIBLE PROBLEMS:

Status LED does not light

Status LED is flashing

Output stuck (high or low)

Output not tracking pressure properly

### POSSIBLE SOLUTIONS:

- Check power connections for proper power

- Sensor is set to 4-20mA output

- The unit is performing an auto-zero. Wait 20 seconds and check again.

- Remove pressure from ports and perform auto-zero procedure

- Check rotary switch for proper pressure range selection

- Check rotary switch for proper output range selection

## Specifications

### Power:

7 to 40 VDC (4 to 20 mA Output)

7 to 40 VDC or 18 to 32 VAC (0 to 5 or 1 to 5 VDC Output)

13 to 40 VDC or 18 to 32 VAC (0 to 10 or 2 to 10 VDC Output)

### Power Consumption:

20 mA max, DC only at 4 to 20 mA Output

5.2 mA max DC at 0 to 5 or 0 to 10 VDC Output

0.12 VA max AC at 0 to 5 or 0 to 10 VDC Output

### Load Resistance:

4 to 20 mA Output 850  $\Omega$  Maximum @ 24 VDC

0 to 5 or 0 to 10 VDC Output 6K $\Omega$  Minimum

### Accuracy:

$\pm 0.25\%$  FS @ 72°F (22°C)

$\pm 0.005"$  WC ( $\pm 1.24$  Pa)

**Stability:**  $\pm 0.25\%$  FS per year

**Overpressure:** Proof 270" WC (67 kPa)

**Media:** Clean, dry, non-corrosive gases

**Compensated Temperature Range:**

32 to 122°F (0 to 50°C)

**Environmental Operating Range:**

-4 to 140°F (-20 to 60°C)

**Storage Temperature:**

-40 to 185°F (-40 to 85°C)

**Humidity:** 0 to 95% RH, non-condensing

### Wiring:

2 wires (4 to 20mA Current loop)

3 wires (AC or DC powered, VDC output)

**Port Size:** 1/4" barb

### Enclosure Material:

UV-resistant Polycarbonate, UL94, V-0

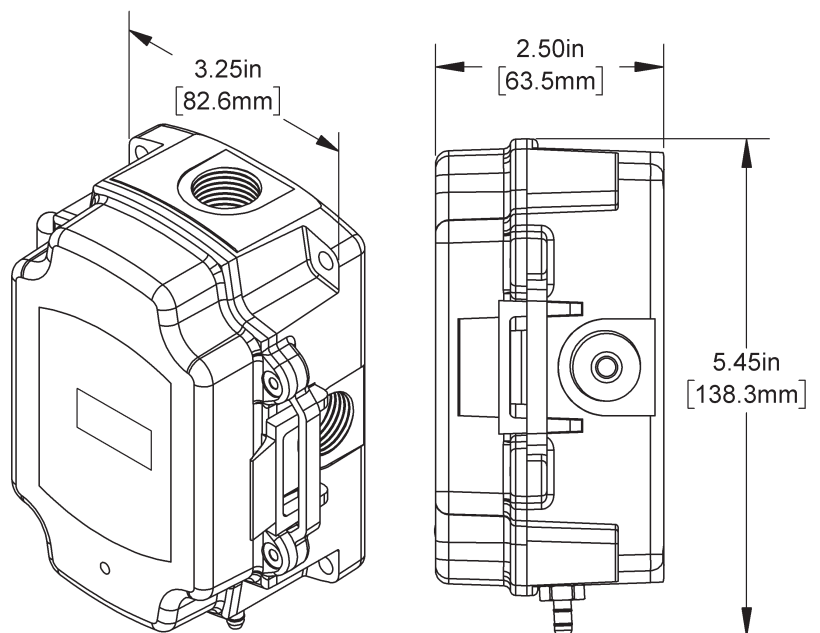
**Enclosure Rating:** IP66, NEMA 4

### Agency:

CE EN 61326-1:2013 EMC (Industrial Electromagnetic Environment), UL, RoHS

### Selectable Low Ranges

<u>Inches WC</u>	<u>Pascals</u>
0 to 0.10.....	0 to 30
0 to 0.25.....	0 to 50
0 to 0.50.....	0 to 100
0 to 0.75.....	0 to 175
0 to 1.00.....	0 to 250
-0.10 to 0.10 .....	-30 to 30
-0.25 to 0.25 .....	-50 to 50
-0.50 to 0.50 .....	-100 to 100
-0.75 to 0.75 .....	-175 to 175
-1.00 to 1.00 .....	-250 to 250



Specifications subject to change without notice.