

OPTIONS, ACCESSORIES AND ENGINEERING

| INDEX OF SECTIONS | PAGE |
|--|------|
| Options and Accessories Overview | 2 |
| Construction Options - Hanger Bracket and Inlet Attenuator | 4 |
| Insulation Options | 5 |
| Hot Water Coil Access | 6 |
| Inlet Flow Sensors | 7 |
| Primary Air Dampers | 11 |
| Hot Water Coils | 12 |
| Electric Heat | 13 |
| Motors | 19 |
| Factory Provided Controls | 23 |
| Sound Path Attenuation Assumptions | 31 |
| System Design and Noise Generation | 33 |
| Sensor Calibration for SR-500 | 34 |
| Balancing Fan Boxes with Induction Baffles | 35 |
| ECO Ultra Low Leakage ATU's | 36 |
| Option Codes and Descriptions | 37 |
| Electric Heat Option Descriptions | 48 |

OPTIONS, ACCESSORIES, AND ENGINEERING OVERVIEW

CONSTRUCTION:

- 20 gauge construction available on all units, except retrofit units.
- Hanger brackets available for all units. Metal “L” brackets (4 per unit) which are shipped loose for field installation. Brackets are provided with a 5/8" diameter hole and vibration isolation grommet.
- Inlet attenuators available for fan powered units. The opening is on the side of the box, and the insulation type will match whatever is chosen for the unit. With an induction mounted coil, the filter is on either the top or bottom.
- Individual cartoning is available for all XG-TH / XG-TL units.

CONTROL ENCLOSURES:

- Dust tight control enclosures available for all units. The damper control enclosure is provided sealed to prevent light or dust from entering the enclosure when the cover is in place.
- Oversized control enclosure and cover available on all single duct, dual duct, and retrofit units when the DDC controls are too large for the standard enclosure.
- Control enclosures also available with a sliding control cover on all single duct, dual duct, retrofit units, as well as the XG-FCQ. The cover slides towards the primary inlet. This option is available for both the standard and oversized control enclosures.

FILTERS:

- Fan powered units have optional 1" or 2" filter racks with filters. Filters are installed at the fan air intake and have a MERV 6-7 rating. Spare filters can also be ordered and ship loose.

INSULATION:

- All units available with dual density fiberglass insulation. Available thicknesses are 1/2" and 1". XG-FCI and XG-FVL can only accommodate 1/2" thickness.
- All units available with foil-faced fiberglass insulation, 1.5 lbs density. Available thicknesses are 1/2", 3/4", and 1". XG-FCI and XG-FVL can only accommodate 1/2" thickness.
- All units except XG-FCI and XG-FVL available with foil-faced fiberglass insulation, 4lbs density. Only available in 1" thickness.
- All units available with ThermoPure closed cell foam insulation. Available thicknesses are 1/2" and 1". XG-FCI and XG-FVL can only accommodate 1/2" thickness.
- Single duct (XG-TH, XG-TL) and dual duct (XG-DD, XG-DH) units are available with solid double-wall / metal lined insulation. The double wall is available with either 1/2" or 1" fiberglass insulation between the unit and metal liner.

ACCESS:

- All units without heat have an optional access panel available for inspection of the damper. The panel is rectangular and gasketed, and is installed with zip screws.
- Protective screen for XG-TH / XG-TL units with electric heat. This allows an access panel to be installed, but blocks contact with the electric heat elements.
- Optional standard coil access door can be mounted on the top or the bottom of the unit.
- Optional quick release access door available for all units. Available for coil access on units with a hot water coil; available for inspection of damper on all units without heat. The panel is heavy gauge galvanized steel, insulated and gasketed, and is closed with quarter-turn latches. For coil access it can be mounted on either the top or the bottom of the unit.
- Optional high pressure spin-in access door with cam latches available for all units. Available for coil access on units with a hot water coil; available for inspection of damper on all units without heat.

HANDING:

- All single duct and dual duct units are configured with controls and coil connections on the right as standard (looking in direction of air flow). Optional configurations include controls on left, coil connections on right; controls on right, coil connections on left; and both controls and coil connections on the left.
- All fan powered units are configured with the controls and coil connections on the left as standard (looking in direction of air flow). Optional configurations include controls on left, coil connections on right; controls on right, coil connections on left; and both controls and coil connections on right. Optional handing not available on the XG-FVI unit if the coil is mounted on the induction.

CONSTRUCTION OPTIONS

HANGER BRACKETS

Hanger brackets are shipped loose for field installation. The optional hanger brackets (4) are bagged and placed inside the control enclosure on each air terminal. Hanger bracket kit includes:

- (4) 18 Gauge Hanger Brackets
- (12) Sheet Metal Screws
- (4) Isolation Grommets

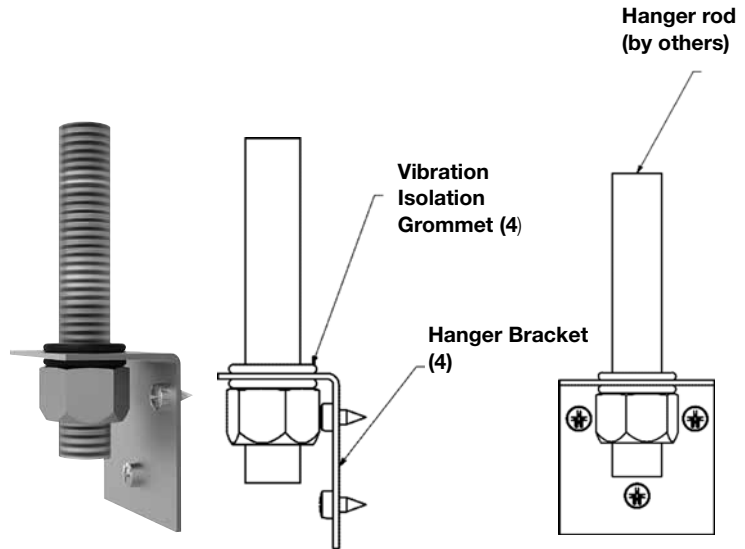

INLET ELBOW ATTENUATOR FOR FAN POWERED TERMINAL UNITS

The inlet elbow attenuator is designed to reduce the radiated noise of fan powered terminal units. The standard inlet elbow attenuator is manufactured from 22 gauge metal and is lined with the same insulation material as the terminal unit it is mounted to. Optional 20 gauge construction and various types of insulation are also available. The standard inlet elbow attenuator is factory installed and ships as an integral part of the terminal. Depending on the terminal unit model and case size, attenuator lengths vary from 16-24". The table to the right lists the Insertion loss credits for the inlet elbow attenuator.

Insertion Loss for Inlet Elbow Attenuator

| dB | CFM | | | | | |
|----|-----|-----|-----|------|------|------|
| | 125 | 250 | 500 | 1000 | 2000 | 4000 |
| | 1 | 4 | 6 | 7 | 10 | 12 |

1. 22 ga. Galvanized steel casing
2. 1.5 lb/ft³ dual density coated fiberglass insulation
3. Insulation meets standards UL 181 and NFPA 90A
4. Performance data is obtained from laboratory testing in accordance with AHRI 880-2011



Typical view showing position of filter with induction mounted coil

INSULATION OPTIONS

Many insulation types are available for use in air terminal units. Each type and thickness of insulation has different thermal and acoustical characteristics as well as unit cost. It is important when specifying any type of insulation to specify not only the material, but the thickness and density as well. For instance, a common fiberglass specification is 1" thick, dual density (1.5lb/ft³ min.) fiberglass insulation. For all insulations, the thicker the insulation, the greater the acoustical and thermal performance, and the higher the cost.

Generally, insulation erosion resistance is stated with respect to UL 181 erosion test. Insulation meeting this specification will not erode or otherwise contribute particulate to the airstream at velocities up to 2500 fpm. Also, insulation is regulated regarding the restriction of fire and smoke spread by NFPA 90A, which requires insulation to be tested at a minimum of 250°F. All insulations offered by Greenheck meet UL 181 and NFPA 90A requirements.

FIBERGLASS

The most common type of insulation applied to ATU boxes is fiberglass. Fiberglass insulation is relatively inexpensive, and provides good thermal and acoustical performance. In most cases, some type of binder is applied to the airstream-facing side of the fiberglass to minimize fiber erosion. This is referred to as 'dual density' insulation as the density of the coated material 'skin' is greater than the core material.

FOIL-FACED FIBERGLASS INSULATION

In situations where erosion resistance above that of dual density is required, foil-faced insulation may be specified. The material, commonly referred to as FSK (foil scrim kraft) facing is adhered to the face of the fiberglass insulation. Critical to the specification is whether or not the FSK material is to be included in the overall material density. Generally, the density of the underlying insulation should be clearly stated.

CLOSED-CELL FOAM INSULATION

Closed-cell foam has acoustical and thermal properties at near parity to dual density fiberglass. In addition to its non-fibrous composition, the material resists mold and mildew growth and is easily cleanable. The material will not wick moisture on exposed edges. The material is more costly than dual density fiberglass and this must be considered when specifying the material.

DOUBLE-WALL INSULATION

For very stringent specifications where fiber erosion must be completely eliminated as a possibility, solid or double wall metal liners have been specified. These liners are extremely expensive and negatively affect the sound performance of the terminal unit to which it is applied.

ACCESS OPTIONS

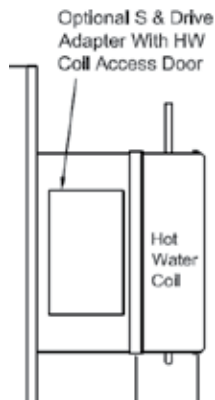

COIL ACCESS

On fan powered terminals with discharge mounted hot water coils that require an access door, a section of insulated duct is added to the discharge of the terminal upstream of the coil.

All coil access doors are insulated with ThermoPure closed cell fiber free insulation. The closed cell foam insulation is used for achieving an air tight seal on the access door. Also, by using the closed cell foam insulation there is no concern for the access door insulation tearing or the edge coating seal being damaged during removal.

INLET FLOW SENSORS

OVERVIEW OF AVAILABLE SENSORS

MULTI-QUADRANT AVERAGING FLOW SENSOR

Greenheck's standard air flow sensor is a multi-quadrant averaging sensor, suitable for use in most differential pressure feedback air control circuits. The accuracy or minimum-maximum set point is $\pm 5\%$ or less when calibration is accurately performed.

CENTER AVERAGING CROSS FLOW SENSOR

Greenheck's multi-point center averaging cross flow sensor is one of the most accurate flow sensors on the market today regardless of inlet conditions. The repeatability of generating a large amplification velocity pressure signal allows quick and easy balancing and commissioning of the Air Terminal Unit.

HIGH GAIN "CROSS-BOW" FLOW SENSOR

The optional "cross-bow" sensor is a premium sensor where a K Factor of 3+ is specified to allow register control or air flow set points. It also allows control at lower CFM settings than the standard Multi-Quadrant Averaging Flow Sensor.

INLET FLOW SENSOR PORTS

Greenheck air terminal units are provided with external piping sensor connections, allowing visual verification of inlet sensor piping connections without having to remove the primary duct or relying solely on tubing color coding. The units are shipped with red stripe tubing on the high pressure port and green stripe tubing on the low pressure port of the inlet sensor. The tubing are short pieces with barbed fittings. The "HIGH" pressure side of the inlet flow sensor is what the air hits first and the "LOW" pressure side of the inlet flow sensor is farthest away from the air flow. All pneumatic piping diagrams and electric, electronic or digital wiring diagrams display the color of tubing used on the "HIGH" and "LOW" pressure ports of the inlet flow sensor.

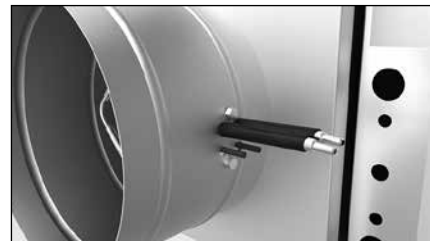

MULTI-QUADRANT AVERAGING FLOW SENSOR



| MODEL | INLET SIZE | K FACTOR |
|---|--------------|----------|
| TXG-H, XG-FCI, XG-FCQ XG-FVI, XG-DD XG-DH, XG-BP XG-RT, XG-RA XG-TL (4 to 10) XG-FCI C2 (4 to 8) XG-FVL C2 (4 to 8) | 04 Rnd | 300 |
| | 05 Rnd | 375 |
| | 06 Rnd | 540 |
| | 07 Rnd | 760 |
| | 08 Rnd | 990 |
| | 09 Rnd | 1250 |
| | 10 Rnd | 1640 |
| | 12 Rnd | 2350 |
| | 14 Rnd | 3250 |
| | 16 Rnd | 4100 |
| XG-TL (12) | 12 Flat Oval | 2270 |
| XG-TL (14) & XG-FVL C6 | 14 Flat Oval | 2850 |
| XG-TL (16) | 16 Flat Oval | 3550 |
| XG-FVL C4 | 14x8 Rect | 2450 |
| XG-FCI C4 | 16x8 Rect | 2770 |
| XG-FCI, XG-FCQ, & XG-FVI C7 | 18x16 Rect | 6200 |
| XG-TH 20 | 20x16 Rect | 6430 |
| XXG-TH 24 | 24x16 Rect | 7270 |

Note: K-factor is the calibration flow constant at 1" w.g. delta P

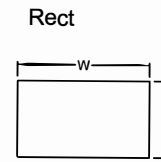
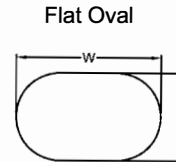
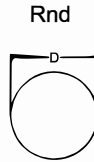

| SIZE | D (in.) |
|--------|---------|
| 04 Rnd | 4 |
| 05 Rnd | 5 |
| 06 Rnd | 6 |
| 07 Rnd | 7 |
| 08 Rnd | 8 |
| 09 Rnd | 9 |
| 10 Rnd | 10 |
| 12 Rnd | 12 |
| 14 Rnd | 14 |
| 16 Rnd | 16 |

| SIZE | W (in.) | H (in.) |
|--------------|---------|---------|
| 12 Flat Oval | 13 | 10 |
| 14 Flat Oval | 16.25 | 10 |
| 16 Flat Oval | 16.25 | 10 |

| SIZE | W (in.) | H (in.) |
|------------|---------|---------|
| 14x8 Rect | 14 | 10 |
| 16x8 Rect | 16 | 10 |
| 20x16 Rect | 20 | 10 |
| 24x16 Rect | 24 | 16 |

$$Cfm = \sqrt{\Delta p} \times K \text{ Factor}$$

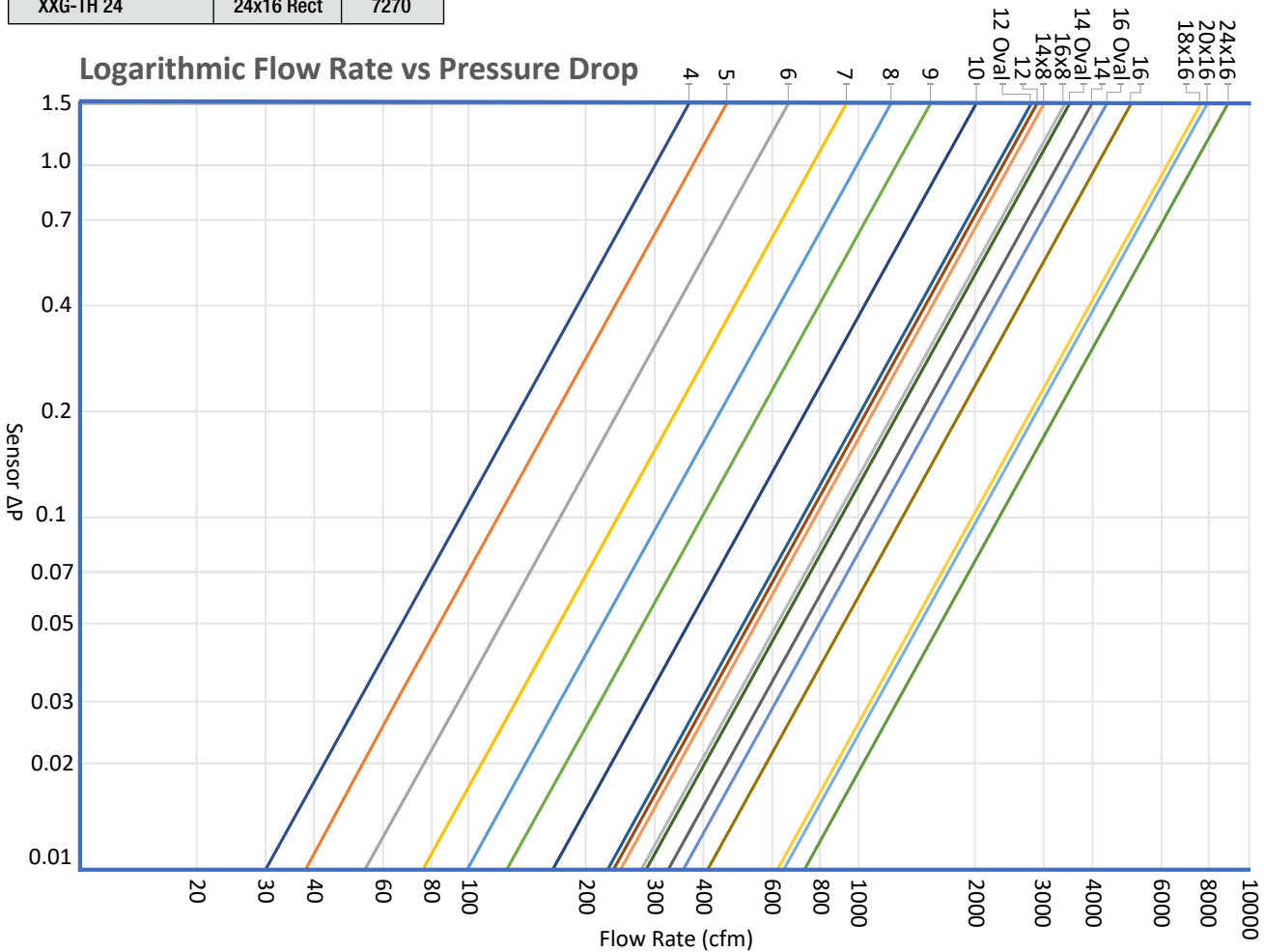

CENTER AVERAGING CROSS FLOW SENSOR

| MODEL | INLET SIZE | K FACTOR |
|-----------------------------|--------------|----------|
| XG-TH, XG-FCI, XG-FCQ | 04 Rnd | 290 |
| | 05 Rnd | 338 |
| | 06 Rnd | 481 |
| | 07 Rnd | 731 |
| | 08 Rnd | 930 |
| | 09 Rnd | 1176 |
| | 10 Rnd | 1472 |
| | 12 Rnd | 1993 |
| | 14 Rnd | 2825 |
| | 16 Rnd | 3570 |
| XG-TL (12) | 12 Flat Oval | 2034 |
| XG-TL (14) & XG-FVL C6 | 14 Flat Oval | 2681 |
| XG-TL (16) | 16 Flat Oval | 3077 |
| XG-FVL C4 | 14x8 Rect | 2139 |
| XG-FCI C4 | 16x8 Rect | 2286 |
| XG-FCI, XG-FCQ, & XG-FVI C7 | 18x16 Rect | 5222 |
| XG-TH 20 | 20x16 Rect | 5922 |
| XG-TH 24 | 24x16 Rect | 7324 |

Note: K-factor is the calibration flow constant at 1" w.g. delta P

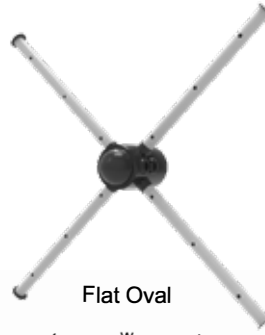

Rnd

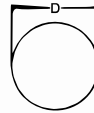

Flat Oval

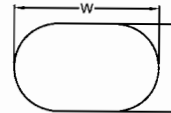

Rect

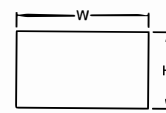

| SIZE | D (in.) |
|--------|---------|
| 04 Rnd | 4 |
| 05 Rnd | 5 |
| 06 Rnd | 6 |
| 07 Rnd | 7 |
| 08 Rnd | 8 |
| 09 Rnd | 9 |
| 10 Rnd | 10 |
| 12 Rnd | 12 |
| 14 Rnd | 14 |
| 16 Rnd | 16 |

| SIZE | W (in.) | H (in.) |
|--------------|---------|---------|
| 12 Flat Oval | 13 | 10 |
| 14 Flat Oval | 16.25 | 10 |
| 16 Flat Oval | 16.25 | 10 |

| SIZE | W (in.) | H (in.) |
|------------|---------|---------|
| 14x8 Rect | 14 | 10 |
| 16x8 Rect | 16 | 10 |
| 20x16 Rect | 20 | 10 |
| 24x16 Rect | 24 | 16 |

$$Cfm = \sqrt{\Delta p} \times K \text{ Factor}$$

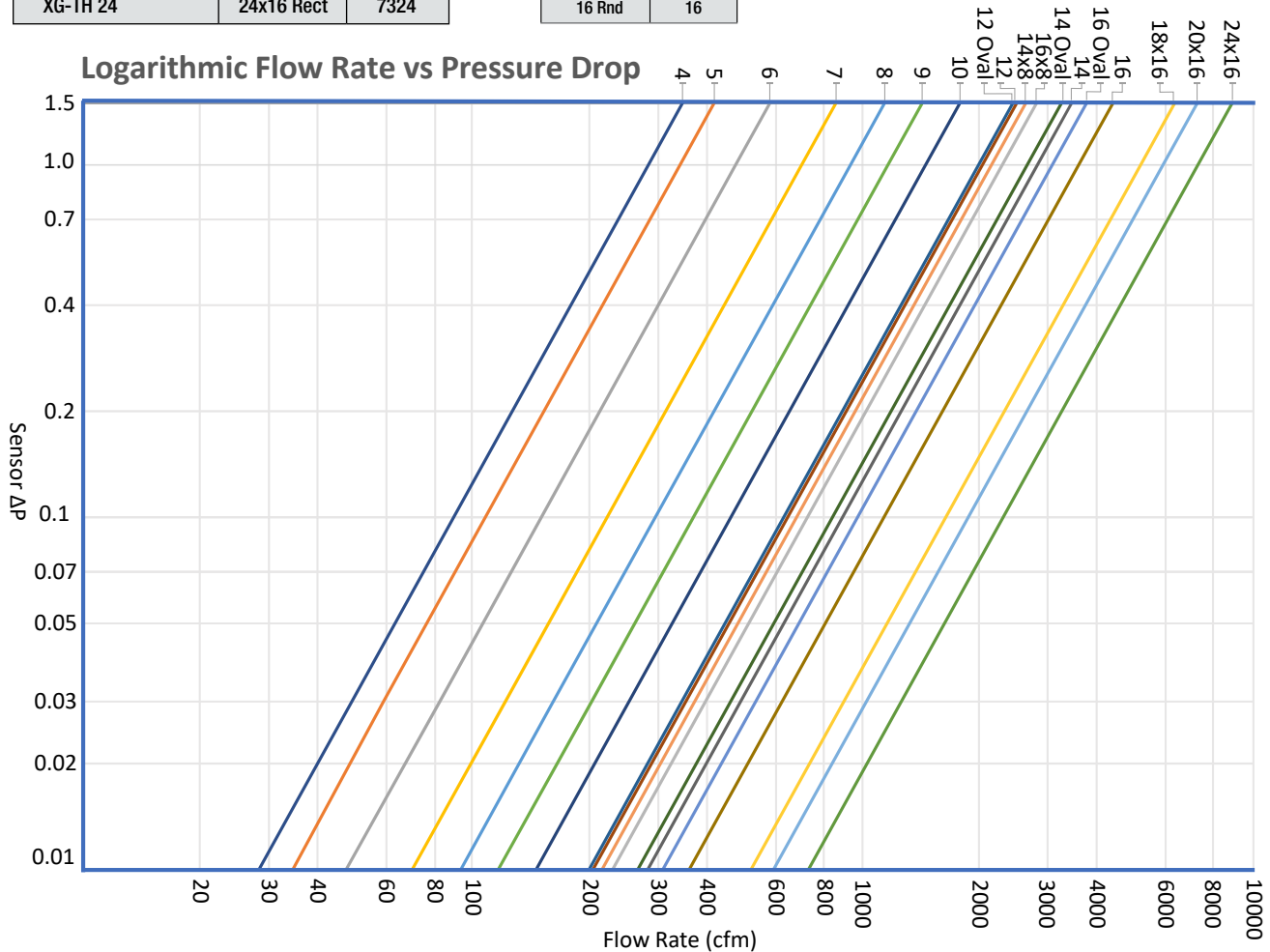

**MULTI-QUADRANT AVERAGING HIGH GAIN
“CROSS-BOW” FLOW SENSOR**

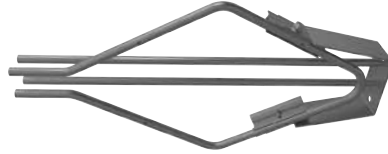

Rnd

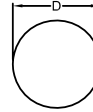

| MODEL | INLET SIZE | K FACTOR |
|-----------------------|-------------|----------|
| XG-TH, XG-FCI, XG-FCQ | 04 & 05 Rnd | 225 |
| XG-FVI, XG-DD | 06 Rnd | 455 |
| XXG-DH, XXG-BP | 08 Rnd | 830 |
| XG-RT, XG-RA | 10 Rnd | 1330 |
| XG-TL (4 to 10) | 12 Rnd | 1770 |
| XG-FCI C2 (4 to 8) | 14 Rnd | 2460 |
| XG-FVL C2 (4 to 8) | 16 Rnd | 3340 |

Note: K-factor is the calibration flow constant at 1" w.g. delta P

| SIZE | D (in.) |
|--------|---------|
| 04 Rnd | 4 |
| 05 Rnd | 5 |
| 06 Rnd | 6 |
| 08 Rnd | 8 |
| 10 Rnd | 10 |
| 12 Rnd | 12 |
| 14 Rnd | 14 |
| 16 Rnd | 16 |

$$Cfm = \sqrt{\Delta p} \times K \text{ Factor}$$

Logarithmic Flow Rate vs Pressure Drop

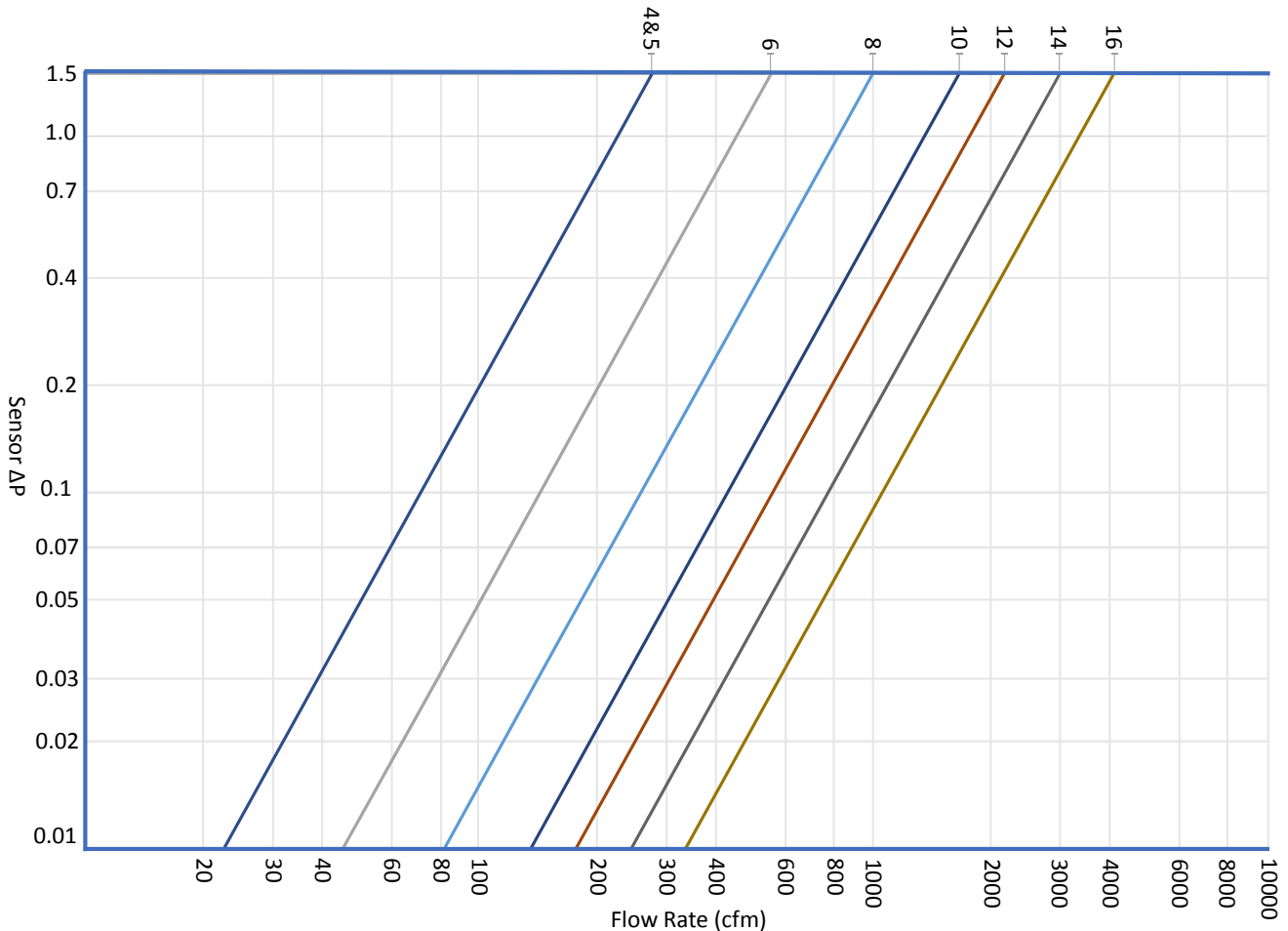

PRIMARY AIR DAMPERS

The Greenheck damper blade is manufactured with a flexible gasket and mounted without adhesives to provide an excellent close off seal. Included on the damper gasket are slits around the perimeter to prevent damper noise at low turn down. Mechanically fastened damper assembly is double layer, 18 gauge equivalent, galvanized steel with integral blade seal. Damper leakage is less than 1% of maximum CFM at 3.0"wg static pressure.

Greenheck has designed the primary air damper shaft assembly for improved performance. The 1/2" diameter shaft is a one-piece, continuous shaft extruded from aluminum alloy. The shaft has a straightness tolerance of 0.010"/ft which provides extremely smooth operation. Determining damper position is straightforward since the shaft has a built-in damper position indicator. The indicating arrows provide a high-contrast against the shaft interior for easily visible damper position confirmation. The continuous shaft is much stronger than multiple-piece shaft assemblies, which rely on a thin damper blade to span the middle part of the damper assembly, thus eliminating the opportunity for flexing and twisting of the damper blade.

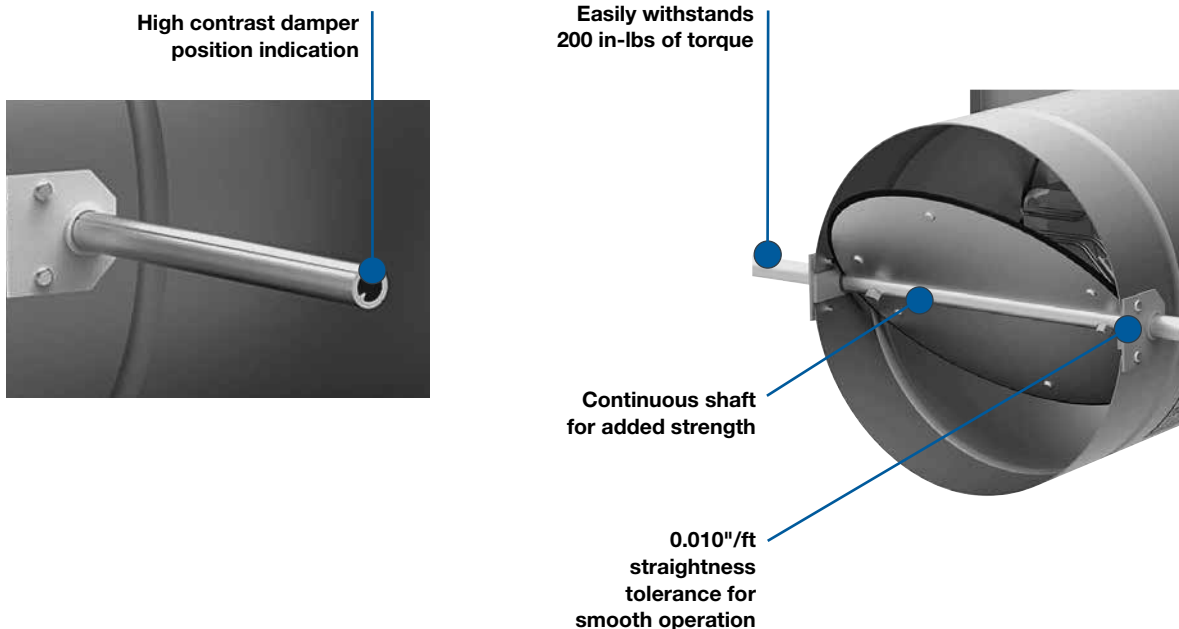

HOT WATER COILS

NOTES FOR COIL PERFORMANCE

- Hot water coil data is for discharge mounted coils.
- For water valve sizing, contact your Greenheck representative.
- Greenheck coil data is AHRI 410 certified.

IMPERIAL NOTES

- Tabulated values are in MBH (thousands of BTU/hr).
- Head loss is in feet of water.
- MBH values are based on a ΔT (temperature difference) of 115°F between entering air and entering water. For other ΔT s, multiply the MBH value by the factors shown:

$$\text{Air Temperature Rise} = 927 \times \text{MBH} / \text{CFM}$$

$$\text{Water Temperature Drop} = 2.04 \times \text{MBH} / \text{GPM}$$

METRIC NOTES

- Tabulated values are in kW (thousands of Watts).
- Head loss is in kPa.
- kW values are based on a ΔT (temperature difference) between entering air and entering water of 64°C. For other ΔT s, multiply the kW values by the factors shown:

$$\text{Air Temperature Rise} = 579 \times \text{kW} / \text{Air Flow (L/s)}$$

$$\text{Water Temperature Drop} = 0.17 \times \text{kW} / \text{Water Flow (L/s)}$$

STANDARD NOTES FOR HOT WATER COILS

- Hot water coils are factory mounted on the discharge of the air terminal.
- Discharge of coil is slip and drive configuration.
- Hot water coils are enclosed in a 20 gauge galvanized steel casing.
- All hot water coils are shipped uninsulated.
- Standard coil fins are 0.045" thick aluminum mechanically bonded to tubing.
- Coils are leak tested at 300psig with minimum burst of 2000 psig at ambient temperature.



| IMPERIAL | | METRIC | |
|-----------------|--------|-----------------|--------|
| ΔT (°F) | Factor | ΔT (°C) | Factor |
| 50 | 0.44 | 30 | 0.48 |
| 60 | 0.52 | 35 | 0.55 |
| 70 | 0.61 | 40 | 0.63 |
| 80 | 0.70 | 50 | 0.78 |
| 90 | 0.79 | 60 | 0.94 |
| 100 | 0.88 | 64 | 1.00 |
| 115 | 1.00 | 70 | 1.08 |
| 125 | 1.07 | 80 | 1.24 |
| 140 | 1.20 | | |
| 150 | 1.30 | | |

ELECTRIC HEAT

STANDARD FEATURES:

- Primary automatic reset thermal cutout
- Secondary manual reset thermal cutout
- Air pressure switch (standard on non-fan powered boxes, optional on fan powered boxes)
- 80/20 nickel chrome element wire
- Magnetic contactor
- Line terminal block
- Staged heat - 1, 2, or 3 stages/steps
- Transformer
- Interlock fan control relay (fan powered boxes only)

OPTIONAL FEATURES:

- Mercury contactors
- SCR heat
- Door interlocking disconnect switch
- Line disconnect fusing
- Transformer with fused primary
- Transformer with fused secondary
- Transformer with both fused primary and secondary
- Fusing per step (for single phase applications)
- Insulated control enclosure
- Dust tight control enclosure
- Access door
- Pilot light, 24V

TOTAL AMPS CALCULATION

- Heater Amps Single Phase = $(kW \times 1000) / (\text{LINE VOLTAGE})$
- Heater Amps Three Phase = $(kW \times 1000) / (\text{LINE VOLTAGE} \times 1.732)$
- Motor F.L.A. is the nameplate amp rating of a given motor (depends on HP and Voltage)
- Total Circuit Amps = (Heater Amps + Motor F.L.A.)
- Minimum Circuit Ampacity = (Total Circuit Amps X 1.25)
- Maximum Overcurrent Protection = (Minimum Circuit Ampacity) rounded up to the nearest standard Fuse or HACR Circuit Breaker size.

SCR HEAT CONTROL:

- 2-10Vdc
- 4-20mA
- Pulse Width Modulation (PWM)

UL 1995 AND GREENHECK ELECTRIC HEAT DESIGN CRITERIA

All Greenheck Air Terminal Units with Electric Heat are built to UL 1995 standards. Intertek/ETL is the listing agency we have chosen to enforce UL 1995 requirements. The agency is primarily concerned with safety of the product, especially in regards to fire and electric shock hazards. The following items are governed by the listing agency to ensure safety:

- Sheet metal thickness and corrosion resistance.
- All internal components must be either UL listed or recognized.
- Internal wiring and electrical spacings of live uninsulated parts in regard to Voltage Ratings.
- Internal Control Enclosure and electrical component temperatures.
- Primary and Secondary temperature limit ratings.
- Airflow and Fan Interlock requirements.
- Discharge and Duct temperature rise. This indirectly influences our minimum airflow requirements.
- Maximum kW for a given unit size based upon 17 kW/Sq. Ft. and available airflow.
- Duct insulation and adhesive temperature and flammability ratings.

All Air Terminal Unit models must be tested before the ETL label is issued to our products. The agency representative chooses at least 2 samples of each model to be tested, usually the largest and smallest units with the maximum kW allowable for each size. A specially designed duct with temperature sensing thermocouples is attached to the discharge of the heater to measure temperature rise under various normal and abnormal operating conditions. All of our units with Electric Heat are designed for zero clearance to combustible materials. This limits our maximum discharge temperature to 200° F and the duct surface temperature to 197° F (Section 45.9 of UL 1995, 3rd Edition).

To meet the above temperature rise, testing has shown that the primary limit control (auto reset thermal cutout) should be rated at 120° F. The spacing between the return bend of the element and the primary limit control, as well as general placement, is determined by this test. As the airflow begins to drop,

glowing of the return bends send radiant energy to the cutout, adding to the air temperature sensed by this device. The cutout is assured of tripping before the maximum temperature is achieved, by breaking the operating or safety contactors and de-energizing the heating elements.

In the event of primary limit control failure, a backup system is employed that is completely independent of the primary limit control or controlled switching device (operating contactor or safety contactor). This secondary limit control system utilizes a manual reset thermal cutout that controls a backup contactor wired in series with the heating elements. The requirements and placement of the manual reset cutout is also determined by testing to limit the duct temperature to a maximum of 212° F (Section 47.2).

To meet the above temperature rise, testing has shown that the secondary limit control (manual reset thermal cutout) should be rated at 160° F maximum. The spacing between the return bend of the element and the primary limit control, as well as general placement, is determined by this test. The cutout is assured of tripping before the maximum temperature is achieved by breaking the backup contactor and deenergizing the heating elements. All tests are conducted under specific duct static pressure conditions.

In addition to temperature rise, a method of fan or airflow interlock system must be provided to prevent heater operation when no airflow is present. Section 26.11 of UL 1995 describes its function.

All single duct units with electric heat utilize an airflow-sensing switch that measures supply airflow at the discharge side near the air valve. It must read a total pressure (static + velocity) of at least 0.05" of positive pressure to operate. On Dust Tight applications, the negative port of this switch must be vented outside of the control enclosure to prevent reading pressure buildup within the enclosure.

All fan powered units with electric heat have a fan interlocking relay that will not allow the heater to energize until power to the fan motor is confirmed. The control transformer is also wired in series with the optional motor fuse, to prevent the heater from energizing by breaking all control voltage to the heater when the fuse opens. The optional airflow-sensing switch can be specified as a secondary device. It requires a probe placed near the blower discharge to sense positive pressure. The fan interlock relay remains operational when the optional airflow switch is chosen.

Units with electric heat should have a minimum airflow of 70 CFM per kW. Also, a maximum leaving air temperature of 115° F should be observed to prevent premature heater coil failure. The Temperature Rise is a function of kW and airflow: $TR = (kW \times 3413) / (CFM \times 1.085)$. The entering air temperature will determine the leaving air temperature: $Entering\ Air\ Temperature + Temperature\ Rise = Leaving\ Air\ Temperature$. In this case, we want to limit the leaving air temperature to 115° F maximum. Ideally, per an ASHRAE Article published in a 1979 handbook, the leaving air temperature should be around 15° F above the room set point to prevent air stratification. Our catalog recommends no more than 20° F above the set point.

How does this all relate to Greenheck design?

The primary cutout limit was selected to be 120° F to meet the Primary Limit Control test. These cutouts are generally accurate within 5° F. To prevent nuisance tripping of the cutout, and eventual fatigue failure, the leaving air temperature must never exceed 115° F. Also, in the event that either the auto reset or airflow switch trips due to sudden loss of airflow or improperly programmed DDC control systems that allow the heater to function during re-calibration, stored heat will build up within the heater, allowing the temperature to continue to rise above the auto reset set point. To prevent unnecessary tripping of the manual reset, the setting of 160° F provides a safe temperature spread and prevents this from occurring. At the same time, it prevents duct temperatures above 212° F from being reached in the event that there is total failure of the primary limit system.

The 70 CFM/kW rule assumes that the inlet air temperature does not exceed 70° F. This temperature is usually less for single duct units (55° F typical). If it is known that the inlet temperature will always be below 70° F, calculation of the Catalog program can be used to determine the outlet temperature per the formulas above. As an example, a 5 kW heater will need at least 350 CFM if the inlet air temperature is 70° F, but this same heater can go as low as 265 CFM if the inlet air temperature is 55° F. Since the ideal leaving air temperature is 95° F or less, it is recommended not to go below 70 CFM per kW.

Fan Powered Units use a mix of Primary Air (about 55° F) and Plenum Air (about 75° F). This mix will usually average out to about 70° F or less unless the primary air is set to zero. This further reinforces the need to limit the minimum airflow setting to 70 CFM per kW.

ELECTRIC HEAT WIRING

All units with electric heat are Single Point electrical connection devices. The power supply voltages can be Single or Three Phase. See the chart below for voltage availability and requirements. In all cases of Three Phase power, only 3 wires of a 4-Wire supply will be used. A separate neutral is not required.

- 120 volts, single phase is derived from a 208 volt, 3-phase, 4-wire supply. The voltage is taken from the grounded neutral and any one of the 3 hot legs.
- 220 volts, single phase (usually 50 / 60 HZ, Overseas) is derived from a 380 volt, 3-phase, 4-wire supply. The voltage is taken from the grounded neutral and any one of the 3 hot legs.
- 240 volts, single phase can be derived from 2 possible sources:
 - 1) Domestically, it is usually a stand alone transformer supplying a 3-phase, 3-wire supply and has no neutral.



| SINGLE DUCTS | | |
|--------------|-------|--------------|
| Supply Volts | Phase | No. of Wires |
| 120 | 1 | 2 |
| 208 | 1 | 2 |
| 220 | 1 | 2 |
| 240 | 1 | 2 |
| 277 | 1 | 2 |
| 380 | 1 | 2 |
| 415 | 1 | 2 |
| 480 | 1 | 2 |
| 415 | 1 | 2 |
| 208 | 3 | 3 |
| 240 | 3 | 3 |
| 415 | 3 | 3 |
| 380 | 3 | 3 |
| 480 | 3 | 3 |

The exception is the residential market where the transformer has an center tapped grounded neutral to supply 120 volts for normal household usage with 240 volts available for heavy appliances, such as central A/C, Cooking Ranges, and Electric Clothes Dryers.

- 2) Commercially, it is usually derived from a 415 volt, 3-phase, 4-wire supply. The voltage is taken from the grounded neutral and any one of the 3 hot legs.
- 277 volts, single phase, is derived from a 480 volt, 3-phase, 4-wire supply. The voltage is taken from the grounded neutral and any one of the 3 hot legs.
 - 208 volts and 480 volts, 3-phase may not have a separate neutral available in some older buildings. This is called a Delta connected supply transformer. All 4-wire supplies are Wye connected transformers. This is not a concern with single duct units, since a separate neutral is not required.



| FAN POWERED | | |
|----------------|---------------|---------------------------|
| Heater Voltage | Motor Voltage | Separate Neutral Required |
| 120 V 1 PH | 120 V 1 PH | NO |
| 208 V 1 PH | 120 V 1 PH | YES |
| 277 V 1 PH | 277 V 1 PH | NO |
| 480 V 1 PH | 277 V 1 PH | YES |
| 208 V 1 PH | 208 V 1 PH | NO |
| 208 V 3 PH | 120 V 1 PH | YES |
| 480 V 3 PH | 277 V 1 PH | YES |
| 208 V 3 PH | 208 V 1 PH | NO |

ELECTRIC HEAT – TYPICAL WIRING DIAGRAMS

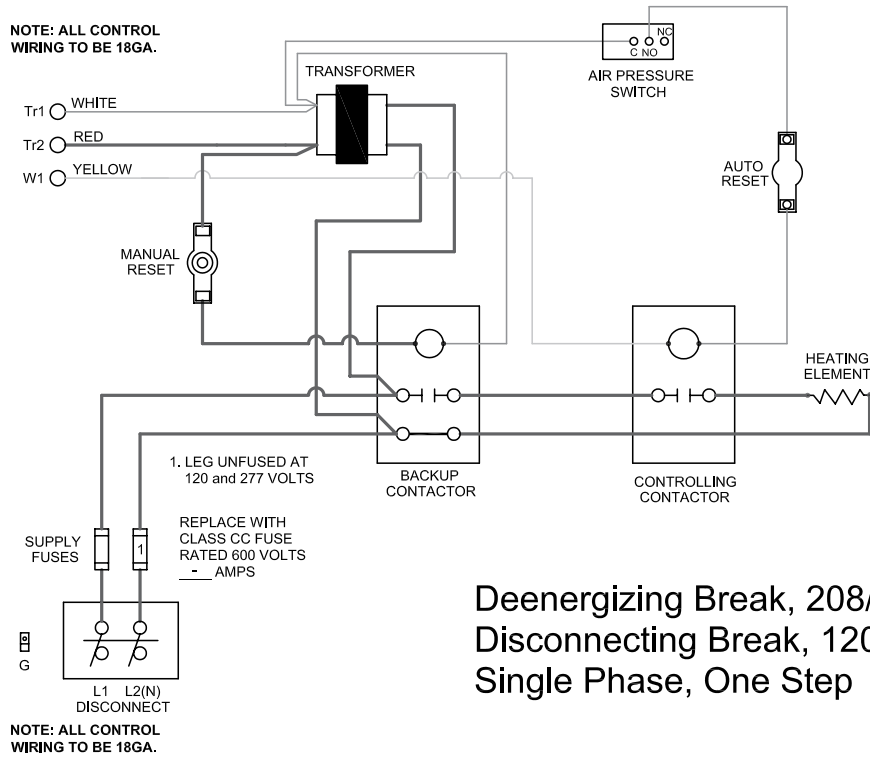

**Deenergizing Break, 208/240/480 V.
Disconnecting Break, 120/277 V.
Single Phase, One Step**

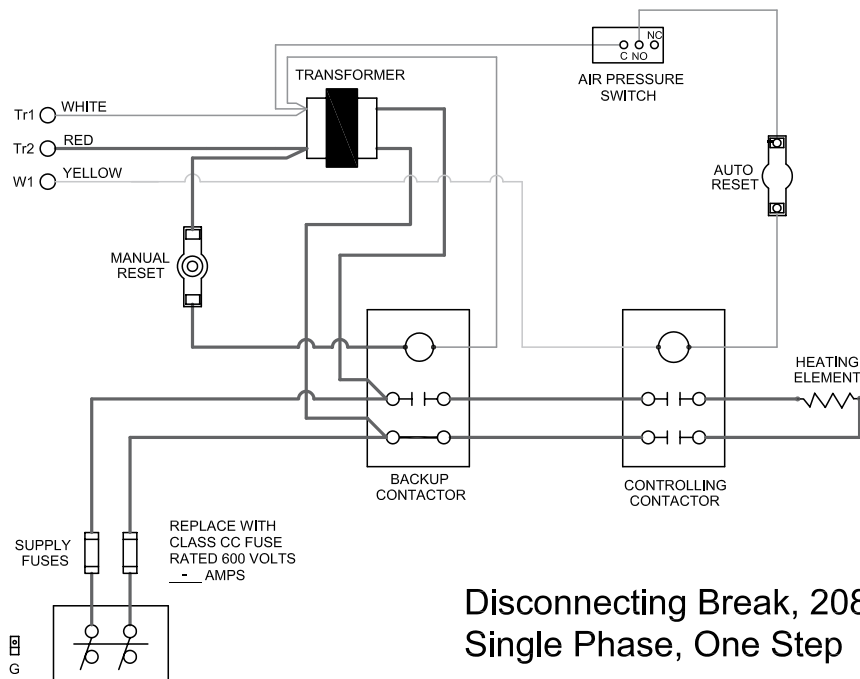

**Disconnecting Break, 208/240/480 V.
Single Phase, One Step**

ELECTRIC HEAT – TYPICAL WIRING DIAGRAMS

NOTE: ALL CONTROL WIRING TO BE 18GA.

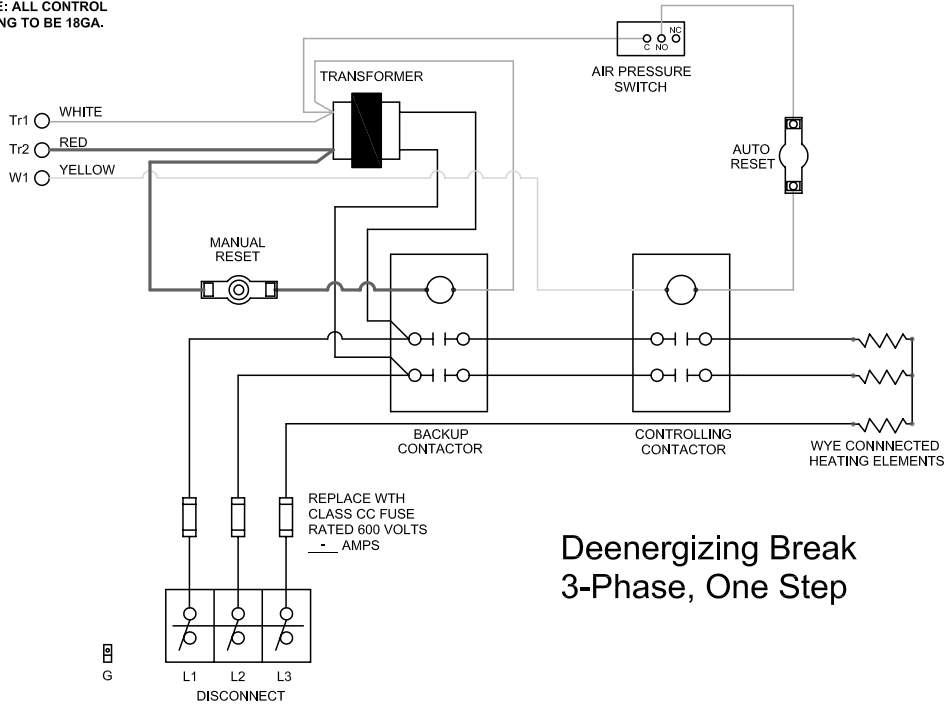

**Deenergizing Break
3-Phase, One Step**

NOTE: ALL CONTROL WIRING TO BE 18GA.

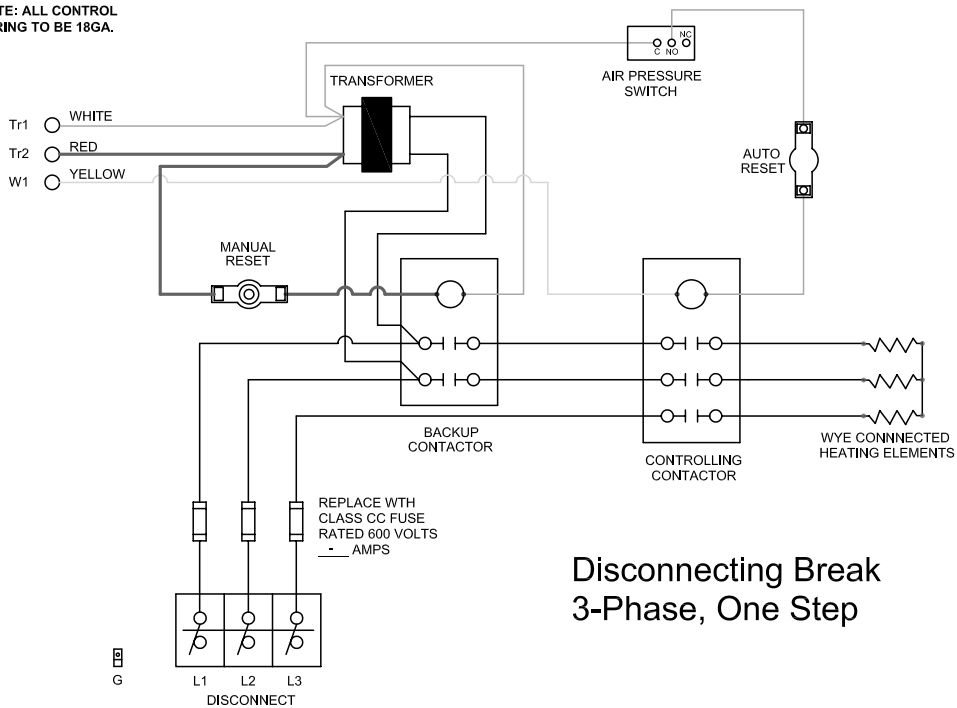

**Disconnecting Break
3-Phase, One Step**

MOTORS

PSC MOTORS

The vast majority of motors used in air terminal units are PSC (permanent split capacitor) type motors. They are generally 6-pole AC motors with a nominal speed of 1075 RPM. They have an efficiency of around 50% at full load. The PSC motor can be used with a speed control down to about 50% of max RPM. When utilized at part load conditions, however, the PSC operating efficiency falls off dramatically, to as low as 15%. When a VAV terminal must operate at part load conditions, special consideration should be given to ECM motors.

AVAILABLE VOLTAGES

Greenheck's motors are available in 3 different voltages, 120v, 208-240v, and 277V. All motors are single phase. Three phase motors or 480V motors are not available.

| Model and Motor Type | Case Size | Motor HP | 120V | 230V | 230V |
|----------------------|-----------|----------|----------------|----------------|----------------|
| | | | Full Load Amps | Full Load Amps | Full Load Amps |
| XG-FCI w/ PSC | 2 | 1/8 | 2.6 | 0.8 | 1.1 |
| | 3 | 1/8 | 2.6 | 0.8 | 1.1 |
| | 4 | 1/4 | 4.8 | 1.9 | 1.9 |
| | 5 | 1/3 | 8.8 | 3.0 | 3.6 |
| | 6 | 1 | N/A | 6.2 | 6.2 |
| | 7 | 3/4 (2) | 22.8 | 8.0 | 8.6 |
| XG-FCI w/ PSC | 2 | 1/4 | 4.8 | 1.9 | 1.9 |
| | 4 | 1/4 (2) | 9.6 | 3.8 | 3.8 |

| Model and Motor Type | Case Size | Motor HP | 120V | 230V | 230V |
|----------------------|---------------|----------|----------------|----------------|----------------|
| | | | Full Load Amps | Full Load Amps | Full Load Amps |
| XG-FCQ w/PSC | 2 | 1/8 | 2.6 | 0.8 | 1.1 |
| | 3 | 1/4 | 4.8 | 1.9 | 1.9 |
| | 4 | 1/3 | 8.8 | 3 | 3.6 |
| | 5 | 1/3 | 8.8 | 3 | 3.6 |
| | 6 | 1/3 (2) | 16.6 | 6 | 7.2 |
| | 7 | 3/4 (2) | 22.8 | 8 | 8.6 |
| XG-FVI w/ PSC | 1 | 1/8 | 2.6 | 0.8 | 1.1 |
| | 2 | 1/6 | 3.1 | 0.8 | 1.1 |
| | 3 | 1/4 | 4.8 | 1.9 | 1.9 |
| | 4 | 1/4 | 4.8 | 1.9 | 1.9 |
| | 5 | 1/3 | 8.8 | 3 | 3.6 |
| | 6 | 1/2 | 9.8 | 3.5 | 3.9 |
| | 7 | 1 | N/A | 6.2 | 6.2 |
| XG-FVL w/ PSC | 2 | 1/8 | 2.6 | 0.8 | 1.1 |
| | 4 | 1/4 | 4.8 | 1.9 | 1.9 |
| | 6 | 1/3 | 8.8 | 3 | 3.6 |
| XG-FCI w/ ECM | 2 | 1/3 | 4.7 | 2.8 | 2.4 |
| | 3 | 1/3 | 4.7 | 2.8 | 2.4 |
| | 4 | 1/2 | 6.6 | 3.9 | 3.4 |
| | 5 | 1 | 12 | 7.1 | 6.2 |
| | 6 | 1 | 12 | 7.1 | 6.2 |
| | 7 | 1 (2) | 24 | 14.2 | 12.4 |
| | XG-FCI w/ ECM | 2 | 1/3 | 4.7 | 2.8 |
| 4 | | 1/3 (2) | 9.4 | 5.6 | 4.8 |
| XG-FCQ w/ECM | 2 | 1/3 | 4.7 | 2.8 | 2.4 |
| | 3 | 1/2 | 6.6 | 3.9 | 3.4 |
| | 4 | 1 | 12 | 7.1 | 6.2 |
| XG-FCQ w/ECM | 6 | 1/2 (2) | 13.2 | 7.8 | 4.8 |
| | 1 | 1/3 | 4.7 | 2.8 | 2.4 |
| | 2 | 1/3 | 4.7 | 2.8 | 2.4 |
| XG-FVI w/ ECM | 3 | 1/2 | 6.6 | 3.9 | 3.4 |
| | 4 | 1/2 | 6.6 | 3.9 | 3.4 |
| | 5 | 1 | 12 | 7.1 | 6.2 |
| | 6 | 1 | 12 | 7.1 | 6.2 |
| | 7 | 1 | 12 | 7.1 | 6.2 |

ECM MOTOR

Greenheck offers the optional ECM motor for the XG-FCI, XG-FCI, XG-FVI and XG-FCQ fan powered terminal units. Add the ECM motor to any of these and you have an ultra high efficient air terminal.

WHAT IS AN ECM MOTOR?

ECM stands for Electronically Commutated Motor. The ECM motor is a brushless-DC motor with built in speed and torque controls.

Unlike a conventional induction motor, ECM motor regulates itself by automatically changing its torque and speed to maintain a pre-programmed level of constant airflow over a wide range of external static pressures and does so without the use of airflow sensors. The ECM's regulated airflow output remains constant over that same range of static pressure.

For optimum heating, the ECM system can be programmed to deliver just the right level of airflow for both low and high.



FEATURES AND BENEFITS

ULTRA HIGH EFFICIENCY

ECM efficiencies are as high as 82%. At full load the ECM is 20% more efficient than a standard induction motor. At low speed the ECM is over 30% more efficient than a standard induction motor. On constant fan speed, the ECM consumes 60-80 Watts as compared to 400 Watts for the induction motor. The permanent magnet DC design allows it to maintain its efficiency over its wide speed range.



FACTORY PROGRAMMED

Programming options for the ECM include: start/stop ramp rates, on/off blower delays, and many other functions all stored in the motor's memory. Even its speed and torque characteristics can be customized to meet specific performance requirements.

SELF REGULATING CONSTANT AIRFLOW

The ECM variable-speed motor can run in a wide range of speeds. The motor can be programmed to deliver constant airflow into a wide range of external static pressures in an air distribution system. This is all accomplished without the use of external sensors.

ECM CONTROLS

Greenheck engineering has carefully integrated the ECM motor into each terminal blower assembly resulting in a terminal fan that produces a constant CFM over a wide range of operating pressures.

The CFM can be adjusted from the specified minimum CFM to the specified maximum CFM by sending the fan a flow index signal. A fan control interface allows external adjustment of the flow index and provides fan on/off control.

ECM CONTROL INTERFACES

Greenheck offers two fan control interface devices for fan terminals equipped with the ECM motor.

MODEL ECM-VCU

The visual fan control interface allows local adjustment of the fan CFM and indicates the fan RPM on an illuminated numerical display. The visual control interface may also be used where automation systems only turn the fan on or off.

MODEL ECM-RPM

The automation fan control interface allows an automation system to control fan on/off, fan CFM, and to monitor the fan RPM from the automation console.

Both control interfaces provide a means to monitor fan RPM. This is an important value to record after air balance, and can be used to diagnose system problems.

MODEL ECM-RPM – REMOTE ADJUSTMENT

The ECM-RPM allows industry standard 2-10 VDC controls to adjust and monitor ECM motor. These are fractional horsepower air moving motors featuring an internal microprocessor. The design provides exceptional efficiency, performance and motor life. The motor may be factory configured to provide constant mass airflow or constant torque.

The ECM-RPM allows remote adjustment of the output from 0% to 100% of the programmed control range. A lamp on the control continuously flashed out the flow index, so instruments are not required to read the value.

The ECM-RPM version provides low voltage on/off controls by switching the motor's "GO" control when the input signal drops below the 2 volt (4 mA) operating point.

Specifications:

| | |
|----------------|-----------------------------|
| Power | NEC Class II Only |
| | 24 Vac + / - 20% 50 / 60 Hz |
| | 2 W, 4 VA + 1VA / Motor |
| Control Signal | 2-10 VDC – 0-100% |
| | 4-20 mA – 0-100% |
| | ON / OFF Control |

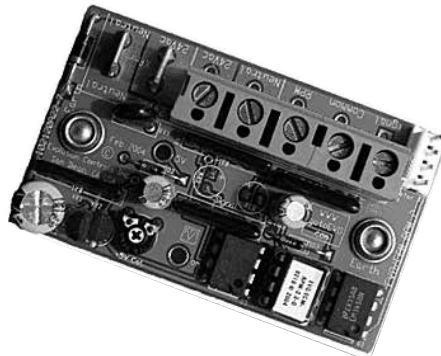

MODEL ECM-VCU – MANUAL ADJUSTMENT

The ECM-VCU control allows accurate manual adjustment and monitoring of fans using ECM motor. These are fractional horsepower air moving motors featuring an internal microprocessor. The design provides exceptional efficiency, performance, and motor life. These self regulating motors may be factory configured so the fan will provide constant mass airflow.

OPERATION

ECM motors configured for Vspd operation are factory configured for external torque or airflow adjustment. The configuration data includes the fan manufacturer's specified adjustment range. A numerical flow index accurately adjusts the fan to the desired torque or air-flow. The flow index is a number from 0-100 having a linear relationship to the minimum to maximum torque or airflow range specified by the motor fan.

The ECM-VCU allows local on/off and fan airflow adjustment. Rotating a single screwdriver adjuster changes the variable output signal to the motor from off to full output. While rotating the adjuster, a numerical flow index is locked on the illuminated numerical display. After adjustment, the display shows fan RPM.

The ECM-VCU may also be used where automation systems only turn the fan on or off.

Specifications:

Power NEC Class II Only
 24 Vac + / - 20% 50 / 60 Hz
 4 W, 6 VA

Flow Index Adjustment 270° rotation
 F Off – 0-100



FACTORY PROVIDED CONTROLS

CONTROL SEQUENCE NOMENCLATURE

The control sequences begin with a digit that refers to a model/terminal type. 1 is single duct model XG-TH or XG-TL, 2 is dual duct model XG-DD or XG-DH, etc. See Chart 1. The middle digits are the code for the sequence. 10 is Pneumatic Pressure Dependent, 82 is Direct Digital Control with Heat/Cool controller with Hot Water Re-Heat, etc. See Chart 2.

The last digit, a letter, refers to the transformer. A is 120/24V, N is No transformer, etc. See Chart 3.

EXAMPLES

880A is fan powered model XG-FVI, XG-FVL with a Digital Cooling only controller and a 120/24v transformer. 983E is a fan powered model XG-FCI, XG-FCI, XG-FCQ with a Digital Heat/Cool controller with Electric Heat.

First Digit-Model-Chart 1

| First Reference Digit | Model Type |
|-----------------------|------------------------------------|
| 1 | XG-TH, XG-TL-Single Duct |
| 2 | XG-DD, XG-DH Dual Duct |
| 3 | XG-BP-Bypass |
| 4 | XG-SR-Retrofit |
| 5 | XG-RA-Retrofit |
| 6 | XG-RT-Retrofit |
| 8 | XG-FVI, XG-FVL-Fan Powered |
| 9 | XG-FCI, XG-FCI, XG-FCQ-Fan Powered |

Last Letter-Transformer-Chart 3

| Last Reference Letter | Transformer |
|-----------------------|---------------------------|
| A | 120/24 V |
| C | 277/24 V |
| F | 208-240/24 V |
| N | No Transformer |
| E | Electric Heat Transformer |

Middle Digits-Control Sequence-Chart 2

| PPD-Pneumatic Pressure Dependent | |
|------------------------------------|--|
| 10N | DA/NC Includes Actuator Only, No Controller or T-stat |
| 12N | RA/NO Includes Actuator Only, No Controller or T-stat |
| PPI-Pneumatic Pressure Independent | |
| 14M | DA/NC Multi Function, Includes Controller and Actuator, No T-stat |
| 15M | DA/NO Multi Function, Includes Controller and Actuator, No T-stat |
| 16M | RA/NC Multi Function, Includes Controller and Actuator, No T-stat |
| 17M | RA/NO Multi Function, Includes Controller and Actuator, No T-stat |
| 35M | Retrofit H-NO, Includes Controller and Actuator, No-T-stat |
| 36M | Retrofit C-NO, Includes Controller and Actuator, No-T-stat |
| 38M | Dual Duct DA/C-NO/H-NC, Includes Controller and Actuator, No T-stat |
| 39M | Dual Duct RA/C-NO/H-NC, Includes Controller and Actuator, No T-stat |
| 40M | Static Pressure Control, Includes Controller and Actuator, No T-stat |
| 41M | Dual Duct DA/C-NC/H-NO, Includes Controller and Actuator, No T-stat |
| 42M | Dual Duct DA/C-NO, RA/H-NC, Includes Controller and Actuator, No T-stat |
| 43M | Dual Duct RA/C-NC, DA/H-NO, Includes Controller and Actuator, No T-stat |
| 44M | Dual Duct DA/C-NO/H-NC Includes Controller and Actuator, No T-stat |
| 45M | Dual Duct RA/C-NO/H-NC Includes Controller and Actuator, No T-stat |
| EPD-Electric Pressure Dependent | |
| 52 | Cooling only, Includes Actuator and T-stat, No-Controller |
| 53 | Cooling with Reheat, Includes Actuator and T-stat, No-Controller |
| 57 | Actuator only, No Controller or T-stat |
| 58 | Dual Duct C-NC/H-NO, Actuator only, No Controller or T-stat |
| API-Analog Pressure Independent | |
| 60 | Cooling only, Includes Controller, Actuator, T-stat |
| 61 | Cooling with Reheat, Includes Controller, Actuator, T-stat |
| 63 | Dual Duct C-NC/H-NC, Includes Controller, Actuator, T-stat |
| 64 | Night Setback/AM Warm up , Includes Controller, Actuator, T-stat |
| 65 | Heat/Cool Auto changover, Includes Controller, Actuator, T-stat |
| 73 | Static Pressure Control, Includes Controller and Actuator, No T-stat |
| DDC-Direct Digital Control | |
| 90 | Cooling only, Includes Controller and Actuator, No T-stat |
| 91 | Heat/Cool Auto Changeover, Includes Controller and Actuator, No T-stat |
| 92 | Heat/Cool with Hot Water Heat, Includes Controller and Actuator, No T-stat |
| 93E | Heat/Cool with Electric Heat, Includes Controller and Actuator, No T-stat |

PNEUMATIC CONTROLS

A direct acting thermostat causes an increase in branch pressure as the room temperature rises. A reverse acting thermostat causes a decrease in branch pressure as the room temperature rises. Since the pneumatic actuator is a spring return device, the damper can be connected so that without main pressure it will return to normally closed position to shut off the air to the room or a normally open position to permit unobstructed air flow to the room.

PNEUMATIC PRESSURE DEPENDENT

Pressure dependent pneumatic air terminal actuators are powered directly by branch line pressure signals from the room thermostat.

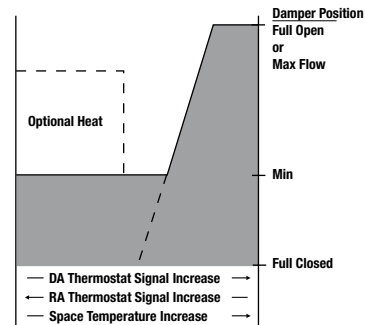

PNEUMATIC PRESSURE INDEPENDENT

Pressure independent pneumatic air terminal actuators are powered by signals from a flow control device which balances pressure readings from the main air supply and the branch air pressure from the thermostat. The damper's position is regulated by the flow control which operates within preset minimum and maximum flow rates.

Multi-function flow controllers for pressure independent applications can be field modified for use with a direct or reverse acting thermostat and the damper actuator can be switched to either normally open or normally closed position without adding control components.

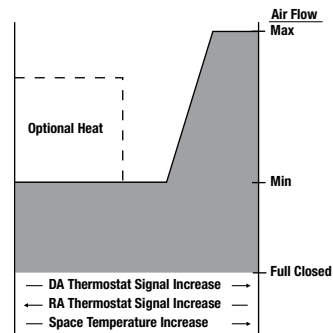

PNEUMATIC-STATIC CONTROL

Local or remote pickup senses duct static and signals controller to maintain constant static at sensing point. It may be used for direct static control or as a bypass flow method. 0"-2" range.

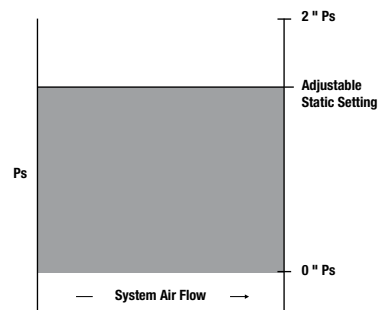

TYPICAL DUAL DUCT PNEUMATIC CONTROLS

PNEUMATIC PRESSURE INDEPENDENT-VARIABLE VOLUME/ DUAL FLOW CONTROLLERS/ZERO MINIMUM

Thermostat signals dual flow controls to regulate hot and cold duct damper positions in sequence. Flow control modulates cold duct damper in response to signals from the room thermostat within preset maximum to 0 CFM range while hot duct remains closed. If room temperature drops below the set point, the cold duct damper is closed and the hot duct damper is modulated between 0 and the maximum CFM range. Once the set point has been reached, neither heating nor cooling occurs.

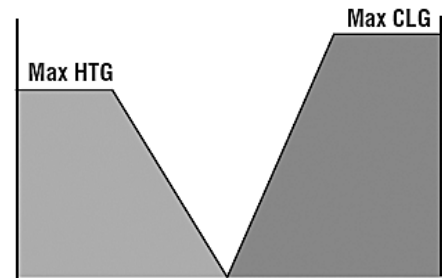

PNEUMATIC PRESSURE INDEPENDENT- VARIABLE VOLUME/ DUAL FLOW CONTROLLERS/REDUCED MIXING

Thermostat signals dual flow controls to regulate hot and cold duct damper positions in sequence. Flow control modulates cold duct damper in response to signals from room thermostat within preset maximum and minimum CFM range while hot duct damper remains closed. If the set point is still not reached, the unit switches from the cooling minimum to the heating minimum CFM with hot and cold air blending. If room temperature still remains below the set point, the cold duct damper goes to minimum or closed and the hot duct damper is modulated between its minimum and maximum CFM range until the set point is reached.

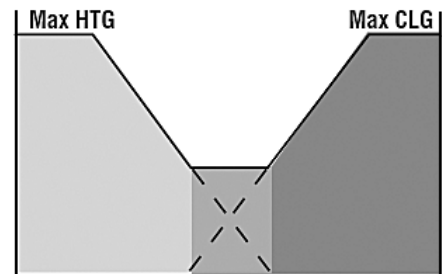

PNEUMATIC PRESSURE INDEPENDENT- CONSTANT VOLUME/DUAL FLOW CONTROLLERS/MIXING SENSORS

Flow controllers respond to signals from the room thermostat in a complimentary fashion so that as the hot duct damper closes, the cold duct damper opens and vice versa. In this way varying volumes of hot and cold air are blended to maintain a constant volume of air to the room.

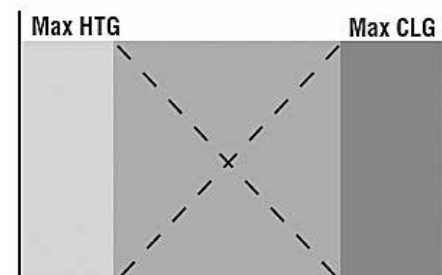

ELECTRIC CONTROL

ELECTRICALLY CONTROLLED AIR TERMINALS

Reversible electric actuators are pressure dependent and are powered directly by signals from the room thermostat. As room temperature rises, the actuator opens the damper to permit a higher flow of cooling air into the room. As temperature falls, the actuator closes the damper to reduce air flow to the room. The electric actuator is not a spring return device. If there is a loss of power to the air terminal, the damper will remain in the position it occupied at the time of the failure.

A mechanical stop is provided with each electric control sequence to assure minimum air flow to the room. The modulating actuator provides floating proportional control of supply air to the room and can be left in a stalled position indefinitely. A 24 volt bi-metallic room thermostat is standard component on each electric control sequence, with the exception of the 57N. A transformer is required to reduce the line voltage to 24 volts to operate the thermostat and the actuator. An optional minimum 40 VA transformer that will step down the primary voltage from 120, 277 or 208-240 line voltage to 24 control voltage.

COOLING ONLY

As room temperature rises, the thermostat signals the actuator to open the damper to its fully open position. As room temperature falls, the thermostat signals the actuator to close the damper to a mechanically determined minimum set point.

COOLING WITH HEAT

As room temperature rises, the thermostat signals the actuator to open the damper to its fully open position. As room temperature falls, the thermostat signals the actuator to close damper to a mechanically determined minimum set point.. this point, an electrical accessory switch energizes optional heat at the minimum air flow rate. Up to two stages heat are available.

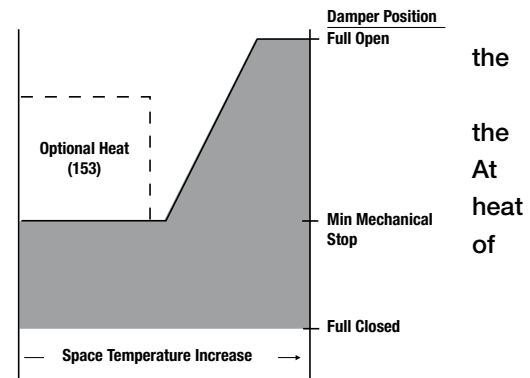

STATIC CONTROL

Static sensor — at terminal or remote — senses static variations and signals controller to maintain static. 0"-1.6" range.

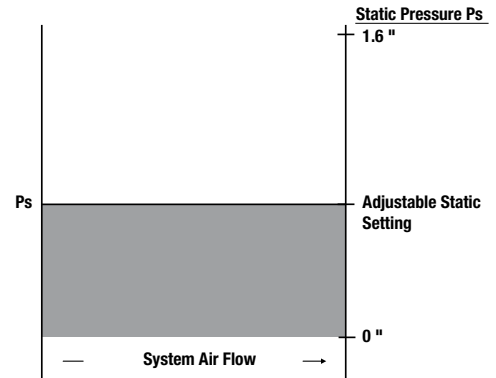

FLOATING ELECTRIC CONTROL

Actuator modulates air flow in response to controller (by others) signals. Signal, 24 volt, may be from a static, velocity or other controller requiring air flow modulation. (Flow sensor and thermostat optional)

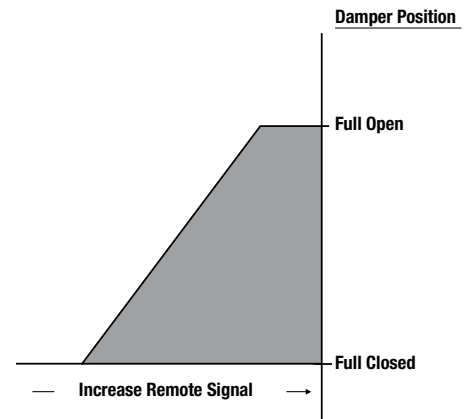

ANALOG ELECTRONIC CONTROLS

Analog electronic flow controls are the only electrical devices available for use with electric or electronic damper actuators that achieve pressure independent control so that variations in supply static pressure do not affect air flow conditions to the room. The analog electronic room thermostats supplied with the control sequences detailed on these pages have field adjustable flow limit set points. The thermostat electronically signals the actuator to open or close the damper in response to room temperature within preset air flow limits. The electric and electronic actuators are not spring return devised. If there is a loss of power to the air terminal, the damper will remain in the position it occupied at the time of power failure.

These state-of-the-art control sequences are available with both analog and computer compatible digital input/output controller options. Numerous control arrangements are possible with electronic control sequencing which are not discussed in this catalog.

All electric and electronic components used in these sequences use low voltage (24V) controls and are readily enclosed with a standard control panel cover. A standard 50Va transformer that reduces 120, 240, or 277 line voltage to 24 control voltage is wired into the control sequence as a standard component. It is assumed that 120 line voltage is being supplied to the air terminal if a different line voltage is not specifically listed.

COOLING ONLY

Electronic thermostat (analog models with integral, adjustable, maximum, and minimum flow limits) signals electronic flow controller to regulate damper position. The damper is rotated to its maximum open position as room temperature rises and to its minimum open position as room temperature falls in proportion to the temperature conditions in the space.

COOLING WITH HEAT

The electronic thermostat (analog models with integral, adjustable, maximum and minimum flow limits) signals the electronic flow controller to regulate the dampers position. The damper is rotated to its maximum open position as room temperature rises and to its minimum open position as room temperature falls in proportion to the temperature conditions in the space. After the damper has reached its minimum position, the thermostat activates the optional heat at an independently selected set point. Up to three stages of heat are available.

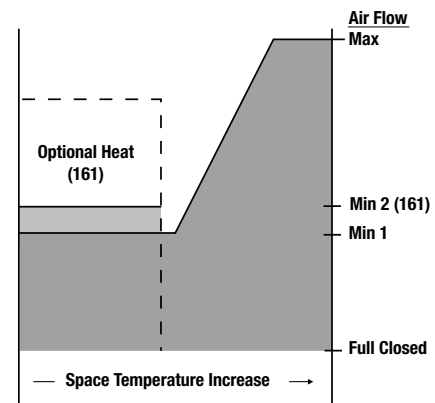

NIGHT SHUTDOWN/MORNING WARM-UP DAYTIME OPERATION

Electronic thermostat (analog models with integral, adjustable, maximum and minimum flow limits) signals electronic flow controller to regulate damper position. The damper is rotated to its maximum open position as room temperature rises and to its minimum open position as temperature falls. After the damper has reached its minimum position, the thermostat actuates optional heat at an independently selected set point. Up to three stages of heat are available depending on the control manufactured selected.

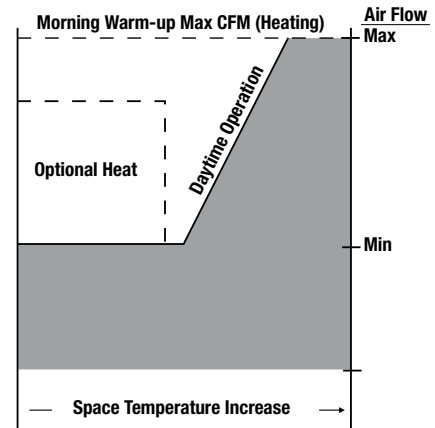

NIGHT SHUTDOWN/MORNING WARM-UP

With central system off, no air or duct mounted heat is supplied to the room. At morning warm up, a duct sensor detects warm air in the central system and drives air terminal to maximum CFM. During warm up, duct heat is held off. When duct sensor detects warm air in the central system, the air terminal automatically reverts to daytime operation.

HEATING/COOLING CHANGEOVER:

A duct thermostat or a remote input signal switches the heat/cool relay to force the system to operate in the desired heating or cooling mode.

COOLING MODE:

The electronic thermostat signals the analog electronic flow controller to regulate primary air damper position. The damper is rotated to its maximum flow settings as room temperature rises and to its minimum flow setting as room temperature falls in proportion to the temperature conditions in the space. For fan powered units, when the primary air damper is at its minimum airflow position, fan induced plenum air is supplied to the room until the room temperature reaches the set point.

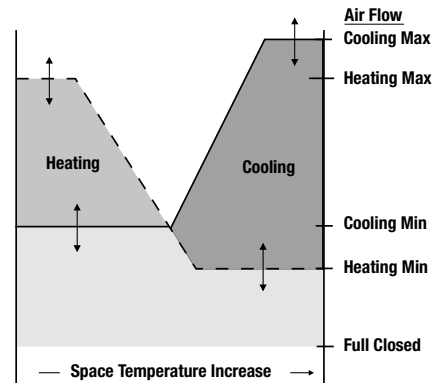

HEATING MODE:

The primary air damper is modulated in response to signals from the electronic room thermostat. In fan powered units, plenum air is induced proportionally to maintain a constant volume of airflow to the room.

DDC ELECTRONIC CONTROL CAPABILITY

The majority of controls installed in HVAC systems today are direct digital controls (DDC). Greenheck can mount and wire any manufacturer's control product that fits on our standard control panel, regardless of the brand. Mounting of other manufacturer's control enclosures or transformer is not available.

In those cases where it is desirable to have the controls field mounted and wired, a basic air terminal without controls can be purchased from Greenheck. The basic unit includes a control panel and cover.

In either case where controls are to be factory mounted and wired by Greenheck or field installed by the control manufacturer, most types of DDC controllers require a flow sensor. Greenheck will provide our multi-quadrant averaging flow sensor which is compatible with all electronic control devices currently on the market. We can mount a control manufacturer's compatible sensor for an additional cost.

Visit Greenheck.com for a complete controls offering

SOUND PATH ATTENUATION ASSUMPTIONS

The current AHRI standard for NC calculation is AHRI 885-08

AHRI-885-08 Radiated Sound Path Assumptions

| Assumptions | Octave Band | | | | | |
|---------------------------|-------------|-----------|-----------|-----------|-----------|-----------|
| | 2 | 3 | 4 | 5 | 6 | 7 |
| Environmental Effect | 2 | 1 | 0 | 0 | 0 | 0 |
| Ceiling/Space Effect* | 16 | 18 | 20 | 26 | 31 | 36 |
| Total dB Reduction | 18 | 19 | 20 | 26 | 31 | 36 |

Note: Attenuation assumptions are based upon factors located in the AHRI Standard AHRI-885-08

Parameters: 1) Mineral fiber ceiling tile, 5/8" thick (35 lb / 3 ft density)
 2) The plenum space is at least 3 ft. deep and either wide (> 30 ft.) or insulated

* Combined effect including absorption of the ceiling tile, plenum absorption and room absorption. This is new to AHRI-885-08; AHRI-885-90 had separate lines for these absorptions.

AHRI-885-08, Appendix E defines "Small" for applications less than 300 CFM

AHRI-885-08 Discharge Sound Path Assumptions, Small

| Assumptions | Octave Band | | | | | |
|---------------------------|-------------|-----------|-----------|-----------|-----------|-----------|
| | 2 | 3 | 4 | 5 | 6 | 7 |
| Environmental Effect | 2 | 1 | 0 | 0 | 0 | 0 |
| Duct Lining | 2 | 6 | 12 | 25 | 29 | 18 |
| End Reflection | 9 | 5 | 2 | 0 | 0 | 0 |
| Flex Duct | 6 | 10 | 18 | 20 | 21 | 12 |
| Space Effect | 5 | 6 | 7 | 8 | 9 | 10 |
| Power Split | 0 | 0 | 0 | 0 | 0 | 0 |
| Total dB Reduction | 24 | 28 | 39 | 53 | 59 | 40 |

Note: Attenuation assumptions are based upon factors located in the AHRI Standard AHRI-885-08

Parameters: 1) Fiberglass duct lining is 1" thick, 8 x 8 duct length is 5 feet
 2) Flex duct is 8" in diameter and 5 feet in length for run to diffuser
 3) Flex duct has vinyl core
 4) Room size is 2400 3 ft
 5) Unit is located 5 feet from measurement point
 6) Sound power split: attenuation credit based on unit feeding one outlet (10 log (# outlets=1)).

AHRI-885-08, Appendix E defines “Medium” for applications from 300 -700 CFM

AHRI-885-08 Discharge Sound Path Assumptions, Medium

| Assumptions | Octave Band | | | | | |
|---------------------------|-------------|-----------|-----------|-----------|-----------|-----------|
| | 2 | 3 | 4 | 5 | 6 | 7 |
| Environmental Effect | 2 | 1 | 0 | 0 | 0 | 0 |
| Duct Lining | 2 | 4 | 10 | 20 | 20 | 14 |
| End Reflection | 9 | 5 | 2 | 0 | 0 | 0 |
| Flex Duct | 6 | 10 | 18 | 20 | 21 | 12 |
| Space Effect | 5 | 6 | 7 | 8 | 9 | 10 |
| Power Split | 3 | 3 | 3 | 3 | 3 | 3 |
| Total dB Reduction | 27 | 29 | 40 | 51 | 53 | 39 |

Note: Attenuation assumptions are based upon factors located in the AHRI Standard AHRI-885-08

- Parameters:
- 1) Fiberglass duct lining is 1" thick, 12 x 12 duct length is 5 feet
 - 2) Flex duct is 8" in diameter and 5 feet in length for run to diffuser
 - 3) Flex duct has vinyl core
 - 4) Room size is 2400 3 ft
 - 5) Unit is located 5 feet from measurement point
 - 6) Sound power split: attenuation credit based on unit feeding one outlet (10 log (# outlets=2)).

AHRI-885-08, Appendix E defines “Large” for applications 700 CFM and greater

AHRI-885-08 Discharge Sound Path Assumptions, Large

| Assumptions | Octave Band | | | | | |
|---------------------------|-------------|-----------|-----------|-----------|-----------|-----------|
| | 2 | 3 | 4 | 5 | 6 | 7 |
| Environmental Effect | 2 | 1 | 0 | 0 | 0 | 0 |
| Duct Lining | 2 | 3 | 9 | 18 | 17 | 12 |
| End Reflection | 9 | 5 | 2 | 0 | 0 | 0 |
| Flex Duct | 6 | 10 | 18 | 20 | 21 | 12 |
| Space Effect | 5 | 6 | 7 | 8 | 9 | 10 |
| Power Split | 5 | 5 | 5 | 5 | 5 | 5 |
| Total dB Reduction | 29 | 30 | 41 | 51 | 52 | 39 |

Note: Attenuation assumptions are based upon factors located in the AHRI Standard AHRI-885-08

- Parameters:
- 1) Fiberglass duct lining is 1" thick, 15 x 15 duct length is 5 feet
 - 2) Flex duct is 8" in diameter and 5 feet in length for run to diffuser
 - 3) Flex duct has vinyl core
 - 4) Room size is 2400 3 ft
 - 5) Unit is located 5 feet from measurement point
 - 6) Sound power split: attenuation credit based on unit feeding one outlet (10 log (# outlets=3)).

SYSTEM DESIGN AND NOISE GENERATION

The central system equipment and distribution ductwork must be properly designed if the air terminal units are to operate correctly. Noise generated at the central system travels through the duct system to the individual zones and can be objectionable when it is sufficient to 'break out' of the duct system or is carried through the duct system to 'discharge' into the occupied zone.

The most common source of objectionable noise emanating from VAV systems arises from high static pressure in primary (upstream of the terminal unit) duct systems. These pressures have a two-fold effect of increasing the central system sound levels and of causing the terminal units to operate noisily. When the pressure is too high, the primary air damper must close to compensate. The air flowing past the damper must do so at a relatively high pressure drop creating objectionable noise levels.

This is seen quite commonly in VAV systems when the highest inlet static pressure in a distribution duct is used as the default condition for all terminal units served by the trunk duct. The result is over sizing of the upstream VAV terminal units. The result is additional system cost, excessive noise, and inefficient operation of the terminal units. To avoid this condition, the designer would be better suited to provide a balancing damper ahead of the upstream branch ducts serving these terminal units, reducing the inlet pressure at each unit.

System noise is also commonly generated by improper duct design or installation. Particular care should be taken in the excessive and improper use of flex duct as it is more susceptible to break out noise and can cause noisy airflow equipment operation when installed in a 'kinked' fashion. Avoid using 'bullhead' tees and tight elbows before and after terminal units and discharge devices.

In order to ensure proper VAV terminal selection, the system sound pressure levels should be determined. These levels can be used in accordance with AHRI Standard 885 to determine the maximum sound power levels acceptable for each terminal unit. Design engineers should familiarize themselves with the standard and perform an acoustical analysis of each critical path within the system. Standard 885 provides the methodology and data to perform such an analysis for most common applications. Critical applications may require consultation with an acoustical consultant.

SENSOR CALIBRATION FOR SR-500

SR-500 - PRESSURE DROP (Ps) AND FLOW SENSOR (Dp)

To determine the minimum pressure drop (Ps) of a SR Retrofit Damper, multiply the nominal width and height in inches and divide by 144 to calculate the duct/damper area in square feet. Divide the the volume of air, Cfm being handled by the damper by the area of the duct/damper. The result will be the duct velocity in feet per minute (Fpm). Duct velocity, Fpm will be used to calculate pressure drop, Ps and flow sensor differential pressure, Dp.



Example: 18" x 12" Duct handling 2400 Cfm

| | | |
|--|---|--|
| Formulae to calculate Duct Area and Fpm: | Width: 18 Inches Height: 12 Inches $Duct\ Area(Ad) = W \times H / 144 = 1.50\ Sq.Ft.$ $Fpm = Cfm / Ad = 1600\ Fpm$ | |
| Formulae to calculate Ps and Dp: | $Min.\ Ps = (Fpm / 3110)\ Squared = 0.26\ in.\ w.g.$ $Dp = (Fpm / 2900)\ Squared = 0.30\ in.\ w.g.$ | |
| Formulae to calculate Min and Max Cfm and Dp: | $Min\ Duct\ Velocity = 500\ Fpm$ $Max\ Duct\ Velocity = 2500\ Fpm$ $Q\ min = Nom.\ Duct\ Area \times 500\ Fpm = 750.00\ Cfm$ $Min\ Dp = (500 / 2900)\ Squared = 0.030\ in.\ w.g.$ $Q\ max = Nom.\ Duct\ Area \times 2500\ Fpm = 3750.00\ Cfm$ $Max\ Dp = (2500 / 2900)\ Squared = 0.74\ in.\ w.g.$ | |

BALANCING FAN BOXES WITH INDUCTION BAFFLES

The two Induction Baffles in the induction opening may be positioned to reduce airflow beyond the lower limits of the motor speed control. The baffles may be positioned from 100% open to approximately 15% open. The added restriction not only can reduce airflow, but will reduce the sound level of the fan box also.

The optimum position of the baffles is to be at the most closed opening that does not reduce the desired airflow.



ECO ULTRA LOW LEAKAGE ATU'S

SINGLE DUCT ECO UNIT, MODEL TH-500 ECO

DUAL DUCT HIGH EFFICIENCY MIXING ECO UNIT, MODEL DH-500 ECO

- The ECO Ultra Low Leakage/High Efficiency Terminal Units are designed and manufactured for quality, performance and very low leakage resulting in improved energy savings.
- For performance characteristics for the XG-TH-500 ECO refer to the corresponding XG-TH-500 size in the catalog.
- For performance characteristics for the XG-DH-500-00 ECO refer to the corresponding XG-DH-500-00 size in the catalog.
- Standard Box is internally lined with ½” fiberglass insulation with a variety of optional insulations available to meet every requirement.
- Standard casing construction is minimum 22 gauge galvanized steel casing and inlet duct. With optional 20 gauge casing.
- Terminals can be provided with hot water coils, Flexmaster Spin-in or Greenheck Recessed Quick Release coil access doors and damper access doors, electric heaters, sound attenuators, and other optional accessories.
- Units are AHRI certified
- Member of US Green Building Council-USGBC
- Hot water coils are available in standard 20 gauge or optional 18 gauge wrapper.
- Optional hot water coil insulated coil covers insulating exposed tubing on both ends.
- Butt welded leak proof primary inlet.
- Optional certified casing and damper leakage is available.
- Casing Leakage: Assembled units shall be so constructed and sealed to limit air leakage to the following listed quantities at 6” static pressure. The following is the maximum allowable casing leakage including all components:

| ECO Low Leakage Construction | | | | |
|------------------------------|----------------------|-----------------|--------------------|--------------------|
| Inlet Diameter | Static Pressure w.g. | Maximum Airflow | Max Casing Leakage | Max Damper Leakage |
| 4 | 6 | 300 | 5 | 5 |
| 5 | 6 | 375 | 5 | 5 |
| 6 | 6 | 540 | 5 | 5 |
| 7 | 6 | 760 | 7 | 7 |
| 8 | 6 | 990 | 9 | 9 |
| 9 | 6 | 1250 | 12 | 12 |
| 10 | 6 | 1640 | 16 | 16 |
| 12 | 6 | 2350 | 23 | 23 |
| 14 | 6 | 3250 | 32 | 32 |
| 16 | 6 | 4100 | 41 | 41 |
| 20 | 6 | 6430 | 64 | 64 |
| 24 | 6 | 7270 | 72 | 72 |

Notes: 1) Casing and Damper leakage shall not exceed 1 % of the maximum rated airflow at 6” w.g.
2) 4” and 5” inlets are built with 6” casings

OPTION CODES AND DESCRIPTIONS

- 01 BACnet SIMPLY VAV WALL SENSOR ONLY**
Wall sensor for temperature sensing only for Simply VAV BACnet.
- 02 BACnet SIMPLY VAV WALL SENSOR WITH SET POINT DIAL**
Wall sensor with added ability to set the room temperature using a set point dial for Simply VAV BACnet.
- 03 BACnet SIMPLY VAV WALL SENSOR WITH SET POINT DIAL AND OVERRIDE**
Wall sensor with added ability to set the room temperature using a set point dial and to override the occupancy/unoccupancy of a building automation system for Simply VAV BACnet.
- 04 BACnet SIEMENS 430 SENSOR ONLY - 540-661B**
Wall sensor for temperature sensing only for BACnet 430 Digital Controller
- 05 BACnet SIEMENS 430 SENSOR WITH SET POINT, 540-665B**
Wall Sensor with added ability to set the room temperature using slide operator. This option will allow the space occupant to override the controller temperature set point for the controller. For BACnet 430 Digital Controllers.
- 06 BACnet SIEMENS 430 SENSOR FULL FEATURED, DISPLAY SET POINT, OCCUPANCY OVERRIDE-540-680FB**
Wall Sensor offers room temperature set point and digital display. Occupancy override allows return to occupied control when scheduled by automation system. For BACnet 430 Digital controller.
- 07 22 GAUGE CONSTRUCTION**
Terminal casing shall be a minimum 22 gauge. Steel internal parts remain unchanged. Single duct Box attenuators are also made of minimum 22 gauge construction due to one piece construction. Inlet attenuators and discharge attenuators on fan boxes are minimum 22 gauge.
- 08 FILTER MOUNTING RACK WITH 2" FILTER**
A dust filter installed at the fan air intake of a fan box. Same as option 32 only 2" thick.
- 09 SPECIAL MERV RATED INDUCTION FILTERS (ADD TO OPTION 32 AND 08)**
Special MERV rated induction filters can be special ordered and installed at the fan air intake. This is an add to option 08 and 32.
- 10 20 GAUGE CONSTRUCTION**
Terminal casing shall be a minimum 20 gauge. Steel internal parts remain unchanged. Single duct Box attenuators are also made of minimum 20 gauge construction due to one piece construction. Inlet attenuators and discharge attenuators on fan boxes are minimum 22 gauge.
- 11 ROUND OUTLET (6, 8, 10, 12, 14, 16)**
This can be round or oval depending on the model (XG-TH or XG-TL). This is a single outlet connected to discharge via slip and drive. Sized the same as the inlet unless otherwise specified. Smaller are ok but larger than inlet only if space is available.
- 12 FLANGED OUTLET**
This option provides a flanged connection on the box discharge. On models XG-TH, XG-TL, XG-BP, and XG-DD, no change in metal size, just form 4 outlet sides out 90 degrees instead of slip and drive.

- 13 THERMOSTAT PNEUMATIC DA, 2 PIPE**
An optional accessory offered for Direct Acting pneumatic controls. Stat should come complete with cover and mounting instructions.
- 14 STANDARD DUST COVER FOR STD CONTROL MOUNTING PLATE**
This is the control panel dust cover offered as standard on models XG-TH500, XG-TL500, XG-DH500, XG-DD500, XG-RT500, XG-BP500 and XG-SR500.
- 15 THERMOSTAT PNEUMATIC RA, 2 PIPE**
An optional accessory offered for Reverse Acting pneumatic controls. Stat should come complete with cover and mounting instructions.
- 16 STANDARD CONTROL MOUNTING PLATE**
This is the control mounting panel offered standard on models XG-TH500, XG-TL500, XG-DH500, XG-DD500, XG-RT500, XG-BP500 and XG-SR500.
- 17 PUBLIX CUSTOM FEATURES**
This is a special option for the model BP500 box constructed for PUBLIX Supermarkets. This consists of round outlet and round discharge, same size as inlet unless specified, on the bypass outlet of the box.
- 18 TRANSFORMER 120/24 VOLT**
This is a 120/24 volt, 40 VA, step down transformer. On models XG-TH500, XG-TL500, XG-DH500, XG-DD500, XG-RT500, XG-BP500 and XG-SR500, the transformer is mounted on top of a 2 x 4" 'J' box inside the standard control mounting panel. This provides protection from the high voltage side of the transformer.
- 19 TRANSFORMER 208-240/24 VOLT**
This is a 208-240/24 volt, 40 VA, step down transformer. On models XG-TH500, XG-TL500, XG-DH500, XG-DD500, XG-RT500, XG-BP500 and XG-SR500, the transformer is mounted on top of a 2 x 4" 'J' box inside the standard control mounting panel. This provides protection from the high voltage side of the transformer.
- 20 TRANSFORMER 277/24 VOLT**
This is a 277/24 volt, 40 VA, step down transformer. On models XG-TH500, XG-TL500, XG-DH500, XG-DD500, XG-RT500, XG-BP500 and XG-SR500, the transformer is mounted on top of a 2 x 4" 'J' box inside the standard control mounting panel. This provides protection from the high voltage side of the transformer.
- 21 BACnet SIMPLY VAV DIGITAL THERMOSTAT**
Full featured Simply VAV BACnet thermostat. At least one of these is required per job for commissioning.
- 22 BACnet SIMPLY VAV ETHERNET CABLE 50FT IN LENGTH**
Each Simply VAV controller will require an ethernet cable to connect the selected wall sensor to the controller.
- 23 BACnet SIMPLY VAV ETHERNET CABLE 50FT IN LENGTH - PLENUM RATED**
Each Simply VAV controller will require an ethernet cable to connect the selected wall sensor to the controller. This cable is plenum rated.

- 24 DUST TIGHT CONTROL ENCLOSURE (P2 ON ELECTRIC HEAT)**
In this application, the damper control enclosure is provided sealed to prevent light or dust from entering enclosure when the cover is in place. On terminals with electric heat, choose option P2 for ‘Dust Tight Enclosure’ on the electric heater. Dimensions are 12”x14”.
- 25 BACnet SIEMENS SENSOR WITH CO2 AND RH AND BLANK FRONT**
Used with Siemens BACnet 430 controller. Temp/CO2/RH blank front
- 26 COLD DUCT ON LEFT**
Used on the models XG-DD500 and XG-DH500, the standard location for the cold duct on these terminals is on the right side looking in the direction of air flow.
- 27 HANGER BRACKETS**
These are metal ‘L’ brackets (4 per terminal) which are shipped loose for field installation. Each bracket is provided with a 5/8” diameter hole and vibration isolation grommet.
- 28 ELECTRONIC ANTI-REVERSING ROTATION DEVICE**
The fan wheel in a constant fan powered box may rotate backwards when primary air from the inlet duct is passing through the fan and the motor is not running. In some case, the fan motor can not overcome the torque developed by the fan wheel when rotating backwards. To prevent reverse rotation, constant fan powered boxes require a means to energize the fan motor during primary fan system start-up. This device will overcome the torque of the motor and allow correct rotation.
- 29 DISCONNECT SWITCH, TOGGLE**
This option is used to de-energize the fan motor when the terminal does not have electric reheat. It can be used in conjunction with option 92 (primary fusing), 93 (secondary fusing) or 96 (primary and secondary fusing).
- 30 BACnet SIEMENS SENSOR WITH CO2 AND RH AND FULL FEATURE DISPLAY**
Used with Siemens BACnet 430 controller. Temp/CO2/RH full feature display.
- 31 DISCONNECT SWITCH, LOW VOLTAGE TOGGLE SWITCH**
This option is used to de-energize low voltage power such as 24 volt control power, 120, 208-240 and 277 volt power. This can be used in conjunction with option 92 (primary fusing), 93 (secondary fusing) or 96 (primary and secondary fusing).
- 32 FILTER MOUNTING RACK WITH 1” FILTER**
This is our standard 1” thick dust filter mounted on the fan air intake of all fan boxes in a side access frame. Our standard filter has a MERV 6-7 rating.
- 33 LINER-SOLID METAL LINER WITH 1/2” INSULATION**
This option is available on models XG-TH500, XG-TL500, XG-DD500 and XG-DH500. This is a solid metal liner made of minimum 24 gauge galvanized steel which totally eliminates exposure of insulation in air stream. The insulation provided is 1/2” thick fiberglass. Accessories such as sound attenuators and electric heat plenum would be insulated with the same material.
- 34 BACnet SIEMENS POWER MODULE**
BACnet Siemens power module required with option 25 or option 30, BACnet Siemens CO2 sensors.

35 HOT WATER 3&4 ROW INSULATED COVER

This is a metal insulated cover used to insulate the connection and return bend sides of the 3 and 4 hot water coil. The insulation used is 1" fiberglass since it is outside the air stream.

36 NOT USED AT THIS TIME**37 INLET ATTENUATOR**

This is an attenuator mounted on the fan air inlet of the fan box. The actual opening is on the side of the box. The insulation in the attenuator will be the same as the box insulation. Material gauge same as case. The actual size is referenced on the submittal drawing.

38 TRANSFORMER 24 VOLT ISOLATION

This is a 24/24 volt transformer used to isolate the 24 volt signal to the controller. Can be used in conjunction with any 24 volt secondary step down transformer or can be used if 24 volt power loop is being provided in the field to the box.

39 LINER-THERMOPURE 1/2"

This is an optional "Fiber-Free" closed cell foam liner used in hospitals, clean rooms and schools. It is washable, durable and non-wicking insulating material. It is mold and mildew resistant. Accessories such as sound attenuators and electric heat plenums would be insulated with the same material.

40 NOT USED AT THIS TIME**41 OVERSIZED 12"x14" CONTROL COVER & ENCLOSURE**

This is an optional control enclosure used on models XG-TH500, XG-TL500, XG-DD500, XG-DH500, XG-RT500 and XG-SR500 when the DDC controls are too large to fit within the standard enclosure.

42 HARD CAST TAPE

Sealing material applied to seams of the ECO series products (XG-TH and XG-DH) for ultra-low leakage applications.

43 RT500 STAINLESS STEEL CONSTRUCTION

This option is for 316L grade stainless steel construction on all metal parts exposed to airstream. SS parts included are inlet tube, damper shaft, damper blades, and multi-quadrant flow sensor.

44 NOT USED AT THIS TIME**45 BACnet SIEMENS CABLE FROM LAPTOP TO WALL SENSOR 540-143**

This is a required cable to connect the wall sensor to the laptop or controller for programming/re-programming the BACnet 430 controller.

46 AIR PRESSURE (AIR PROVING) SWITCH

This option is available to add an Air Pressure(Air Proving) Switch to the control side of a box. Use option 'G' on boxes with electric heat. The air pressure switch is standard on models XG-TH500 and XG-TL500 with electric heat.

47 DOWNSTREAM SENSOR

This downstream sensor is offered on the model XG-DH500. The model XG-DH500 comes standard with sensors in both Hot and Cold inlet ducts. Occasionally, this sensor is required. This sensor comes standard on all pneumatic control sequences where it is required on the diagram in order for the controls operate properly.

48 LINER-THERMOPURE 1”

This is an optional “Fiber-Free” closed cell foam liner used in hospitals, clean rooms and schools. It is washable, durable and non-wicking insulating material. It is mold and mildew resistant. Accessories such as sound attenuators and electric heat plenums would be insulated with the same material. Not available on model XG-FCI-600 or XG-FVL-600.

49 LINER FIBERGLASS 1”

Optional 1” fiberglass insulation. Accessories such as sound attenuators and electric heat plenum would be insulated with the same material. Not available on models XG-FCI or XG-FVL.

50 REMOVABLE ACCESS PANEL ON INLET SENSOR

Optional on the Multi-Point Quadrant Averaging Inlet Flow Sensor. It allows the inlet sensor to be removed for inspection and cleaning. An opening is cut into the primary inlet, a gasketed access door is attached to the sensor and held in place with a latch to prevent any leakage.

51 LINER-SOLID METAL LINER WITH 1” INSULATION

This option is available on models XXG-TH500, XG-TL500, XG-DD500 and XG-DH500. This is a solid metal liner made of minimum 24 gauge galvanized steel which totally eliminates exposure of insulation in the air stream. The insulation provided is 1” thick fiberglass. Accessories such as sound attenuators and electric heat plenum would be insulated with the same material.

52 HOT WATER 1&2 ROW INSULATED COVER

This is a metal insulated cover used to insulate the connection and return bend sides of the 1 and 2 hot water coil. The insulation used is 1” fiberglass since it is outside the air stream.

53 SLIDING CONTROL COVER & ENCLOSURE

This optional control enclosure has a sliding lid where space is critical. It slides towards the primary inlet and prevents lid from being removed and misplaced. Offered on models XG-TH500, XG-TL-500, XG-DD500, XG-DH500, XG-RT500, XG-SR500 and XG-BP500.

54 OVERSIZED 12x18” SLIDING CONTROL COVER & ENCLOSURE

This is the same as option 53 and is used on models XG-TH500, XG-TL500, XG-DD500, XG-DH500, XG-RT500 and SG-SR500 when the SG-DDC controls are too large to fit within the standard enclosure.

55 NOT USED AT THIS TIME**56 ACTUATOR ELECTRIC 24V 90 SECONDS**

Optional 24 volt, 35 inch-lb. direct drive power open power closed electric actuator with a 90 seconds travel time.

57 ECM MOTOR-RPM Control

This allows standard 2-10 volt DC from the controls to adjust and monitor the ECM motor. Typically used on Parallel Fan Boxes.

58 ECM MOTOR-VCU Control

This allows accurate manual adjustment and monitoring of ECM motor. Rotating a screwdriver adjuster changes the variable output signal to the motor. While rotating the adjuster, a numerical flow index from 0-100 is locked on the illuminated display. After the adjustment, the display shows RPM. Typically used on Series Constant Volume Fan Boxes.

59 LOW TEMPERATURE DESIGN

This design is for applications when the entering air temperature is below 50°F. 1" Thermopure has to be chosen as the insulation by the user. Fan powered boxes will have the internal section of the primary inlet duct insulated with 1" fiberglass. All seams will be caulked on the header plate of the electric heat rack assembly and where the header plate contacts the casing.

60 QUICK RELEASE BOTTOM ACCESS DOOR

This option features a recessed access door with quarter turn latches for fan boxes. Although all fan boxes come standard with a bottom motor/blower access door they are held in place with zip screws and the panel is not recessed.

61 TH, COIL THEN SA (ADD TO BOX, SA AND COIL PRICE)

The standard construction for XG-TH500 and XG-TL500 is sound attenuator then hot water coil. This option allows the hot water coil to be mounted between box and the sound attenuator.

62 LOW FLOW HIGH GAIN INLET SENSOR

This sensor is for applications where the air flow is below what is recommended in our catalog. Used on boxes with 6" primary inlet.

63 INDIVIDUAL CARTONING

Use this option when individual cartoning is specified on models XG-TH/XG-TL506-510.

64 INDIVIDUAL CARTONING

Use this option when individual cartoning is specified on models XG-TH/XG-TL512-516.

65 ACTUATOR KMC MODEL MEP-5061

Optional floating, 24 volt, 50 inch/lbs, direct drive, power open power closed, 5 minute travel time electric actuator. Specified on all Publix Supermarkets projects.

66 LINER-FOIL FACED-POLYARMOR 1", 1.5 LBS

This provides polyester insulation that is covered with a scrim backed foil facing. All edges will be covered. Accessories such as sound attenuators and electric heat plenum would be insulated with the same material. Not available on model XG-FCI-600 or XG-FVL-600.

67 18 GA WRAPPER ON HOT WATER COIL

This option adds an 18 ga wrapper on the hot water coils when specified. The standard hot water coil wrapper is 20 ga. Used on University of Texas boxes.

68 DOWNSTREAM SENSOR FOR BP-600 (FIELD INSTALLED)

Because of the balancing damper installed in the primary inlet of the BP600, the flow sensor, when required, will have to be mounted downstream a minimum of 36" from the discharge of the box. This sensor is not a standard feature of the box.

69 EXTRA INDUCTION FILTER

This option allows an extra induction filter to be ordered and shipped loose on all fan boxes. This enables the construction filter to be removed and the extra filter can be installed at building startup.

70 LINER-FOIL FACED 1/2", 1.5 LBS

This provides insulation that is covered with a scrim backed foil facing. All edges will be covered. Accessories such as sound attenuators and electric heat plenum would be insulated with the same material.

- 71 LINER-FOIL FACED 1", 4LBS WITH "Z" BRACKET**
This provides insulation that is covered with a scrim backed foil facing. A metal 'Z' bracket is provided on the discharge to encapsulate the insulation. Accessories such as sound attenuators and electric heat plenum would be insulated with the same material. Not available on model XG-FCI-600 or XG-FVL-600.
- 72 Z' BRACKET ON DISCHARGE WITH STANDARD INSULATION**
This option provides a metal barrier on the discharge of the box when using fiberglass insulation. Can be used with standard 1/2" fiberglass, option 49, 70, 74 and option 77. This is standard feature on option 71.
- 73 ACCESS DOOR WITH PROTECTIVE SCREEN ON BOXES WITH ELECTRIC HEAT**
This option allows an access panel to be installed on a XG-TH500 or XG-TL500 also allowing some protection from a person coming in direct contact with the heater elements. A protective screen is installed on the upstream side of the element rack.
- 74 LINER-FOIL FACED 3/4", 1.5 LBS**
This provides insulation that is covered with a scrim backed foil facing. All edges will be covered. Accessories such as sound attenuators and electric heat plenum would be insulated with the same material. Not available on model XG-FCI-600 or XG-FVL-600.
- 75 CHICAGO CODE (WITH ELECTRIC HEAT)**
This is a special feature required by the City of Chicago. The feature includes a terminal block with jumper installed for connection of optional remote disconnect. This does not include option A1D or P2.
- 76 NOT USED AT THIS TIME**
- 77 LINER-FOIL FACED 1", 1.5 LBS**
This provides insulation that is covered with a scrim backed foil facing. All edges will be covered. Accessories such as sound attenuators and electric heat plenum would be insulated with the same material. Not available on model XG-FCI-600 or XG-FVL-600.
- 78 BACnet SIEMENS 430 CABLING TO WALL SENSOR, 25 FT 588-100A**
Each controller will require a cable to connect the selected wall sensor to the controller. This cable is configured with connections for easy installation.
- 79 BACnet SIEMENS 430 CABLING TO WALL SENSOR, 50 ft 588-100B**
Each controller will require a cable to connect the selected wall sensor to the controller. This cable is configured with connections for easy installation.
- 80 BACnet SIEMENS 430 CABLING TO WALL SENSOR, 100 ft 588-100C**
Each controller will require a cable to connect the selected wall sensor to the controller. This cable is configured with connections for easy installation.
- 81 MOTOR FUSING**
This option provides a fuse in the motor circuit for protection of the motor. The fuse is a time delay type that is sized to absorb motor amp draw during startup and protection during running.
- 82 SLIP AND DRIVE CONNECTION**
This option provides a slip and drive connection on the box discharge. Boxes provided with hot water or electric reheat offer slip and drive connection on discharge as standard construction. Models XG-FVI-500, XG-FVL-600, XG-FCI-600, XG-FCI-600 and DH500 come standard with flanged connection on discharge.

83 FLEXMASTER SPIN-IN ACCESS DOOR

This is a heavy gauge galvanized steel insulated and gasketed round spin-in hot water coil access door with cam latches. It is not reset or flush with the outer wall of the box.

84 RECESSED QUICK RELEASE COIL ACCESS DOOR MOUNTED ON BOTTOM

This is a heavy gauge galvanized steel insulated and gasketed rectangular recessed hot water coil access door with quarter turn latches.

85 STANDARD COIL ACCESS DOOR MOUNTED ON BOTTOM

This is a rectangular gasketed hot water coil access door that is installed with zip screws around the perimeter.

86 STANDARD COIL ACCESS DOOR MOUNTED ON TOP

This is a rectangular gasketed hot water coil access door that is installed with zip screws around the perimeter.

87 RECESSED QUICK RELEASE COIL ACCESS DOOR MOUNTED ON TOP

This is a heavy gauge galvanized steel insulated and gasketed rectangular recessed hot water coil access door with quarter turn latches.

88 CONTROL AND REHEAT (ELECTRIC OR WATER) CONNECTIONS ON LEFT

On models XG-TH500, XG-TL-500, XG-RT500, XG-SR500 controls and or reheat connections are located on the right looking in the direction of air flow. Left hand is the standard location for XG-FVI-500, XG-FVL-600, XG-FCI-600, XG-FCI-600 and XG-FCQ-700.

89 CONTROL CONNECTIONS ON RIGHT AND WATER COIL CONNECTIONS ON LEFT

This option allows the controls and hot water coil connections to be on opposite sides if access is an issue.

90 CONTROL CONNECTIONS ON LEFT AND WATER COIL CONNECTIONS ON RIGHT

This option allows the controls and hot water coil connections to be on opposite sides if access is an issue.

91 CONTROL AND REHEAT (ELECTRIC OR WATER) CONNECTIONS ON RIGHT

On models XG-FVI-500, XG-FVL-600, XG-FCI-600, XG-FCI-600 and XG-FCQ-700 the controls and or reheat connections are located on the left looking in the direction of air flow. This is the standard location for XG-TH500, XG-TL-500, XG-RT-500 and XG-SR-500.

92 PRIMARY FUSING ON TRANSFORMER

This option provides protective fusing on the primary side of the transformer. This is not to be used with electric heat (use option B2 with electric heat).

93 SECONDARY FUSING ON TRANSFORMER

This option provides protective fusing on the secondary side of the transformer. This is not to be used with electric heat (use option B3 on electric heat).

94 NOT USED AT THIS TIME**95 MOUNT COIL ON INDUCTION**

Induction mounted hot water coil is offered on model XG-FVI-500 (except case 7) and XG-FVL-600.

96 NOT USED AT THIS TIME

97 CERTIFIED LEAKAGE TEST

This is an optional requirement offered on XG-TH-ECO500 and XG-DH-ECO500 box and XG-RT500 unit. It is specified on University of Texas projects. This provides certified damper and casing leakage test for the box established by UT.

98 BRONZE BEARING ON DAMPER SHAFT

In this option the damper rotates in a sintered bronze bearing. Another optional requirement for UT.

99 SPECIAL OPTION

This option number warns of something special. This option is for special requirements we offer but are not covered in the software. A pop-up window allows you to add a description and list price. The description will print below each line item after the order has been created. The added cost will be reflected in the software.

100 FLEX MASTER SPIN-IN ACCESS DOOR FOR INSPECTION OF DAMPER

This is a heavy gauge galvanized steel access door insulated, gasketed with cam latches. It is not reset or flush with the outer wall of the box. It is used for inspection of the primary damper.

101 RECESSED QUICK RELEASE ACCESS DOOR FOR INSPECTION OF DAMPER

This is a heavy gauge galvanized steel insulated and gasketed rectangular recessed access door with quarter turn latches used for inspection of primary damper.

102 STANDARD ACCESS DOOR FOR INSPECTION OF DAMPER

This is a rectangular gasketed access door that is installed with zip screws around the perimeter for inspection of the primary damper.

103 SOLID DAMPER SHAFT BOLTED TO DAMPER

One piece solid extruded aluminum damper shaft bolted to damper blades. Normal UT requirement.

104 CROSS-BOW SENSOR

High Gain Cross Bow flow sensor used in applications requiring greater amplification.

105 3RD BEARING BLOCK

3rd bearing block where damper shaft exits casing. This option is sometimes required for ECO (UT) boxes

106 LEED COMPLIANCE-SEALING INLETS AND OUTLETS

To meet LEED requirements, inlets and outlets of terminals need to be sealed to prevent debris from entering into terminal before start up.

107 DISCHARGE ATTENUATORS ON FAN TERMINALS

Where requirement is to provide discharge attenuators on fan terminals, these are shipped loose for field installation. Slip and drive or flanged connection must be specified where attenuator attaches to discharge of terminal.

108 DUAL POINT POWER

On fan powered boxes with electric heat, this option allows separate power to the fan and electric heat. The standard is single point power.

109 NO CONTROL MOUNTING PLATE AND ENCLOSURE

No Enclosure or mounting plate. Available for Non-fan-powered, Non-electric heat, no transformer boxes.

ALL OPTION CODES THAT START WITH “Z” ARE STANDARD DEFAULT CONSTRUCTIONS OF A BOX

- Z01 STANDARD CONTROL ENCLOSURE WITH STANDARD MOUNTING PLATE**
Standard control enclosure with standard mounting plate. Default construction on all models.
- Z02 BOTTOM MOUNT ACCESS DOOR**
Zip screw, non-recessed, bottom mount access door. Default construction on models XG-FCI, XG-FVI, XG-FVL.
- Z03 TOP AND BOTTOM MOUNT ACCESS DOOR**
Zip screw, non-recessed, top and bottom mount access doors. Default construction on model XG-FCQ.
- Z07 22 GAUGE CONSTRUCTION**
Terminal casing shall be a minimum 22 gauge. Default constructions on models, XG-TH, XG-TL, XG-BP, XG-FCI, XG-FVI, XG-FVL, DD, DH, RT, RA. Steel internal parts remain unchanged. Single duct Box attenuators are also made of minimum 22 gauge construction due to one piece construction. Inlet attenuators and discharge attenuators on fan boxes are minimum 22 gauge.
- Z10 20 GAUGE CONSTRUCTION**
Terminal casing shall be a minimum 20 gauge. Default construction on models XG-FCQ and XG-SR. Steel internal parts remain unchanged. Single duct Box attenuators are also made of minimum 20 gauge construction due to one piece construction. Inlet attenuators and discharge attenuators on fan boxes are minimum 22 gauge.
- Z12 FLANGED OUTLET**
Flanged connection on the box discharge. Default construction on models XG-FCI, XG-FVI, XG-FVL and XG-DH.
- Z21 ONE PIECE CONTINUOUS SHAFT**
One piece continuous shaft, aluminum alloy construction. Default construction on all models.
- Z22 PSC FAN MOTOR**
Permanent Split Capacitor fan motor.
- Z23 MULTI POINT QUADRANT AVERAGING FLOW SENSOR**
Default inlet sensor used on all models except model XG-BP.
- Z49 LINER-FIBERGLASS 1”**
1” fiberglass insulation, Default construction on models XG-FCI, XG-FVI, XG-FCQ, and XG-SR. Accessories such as sound attenuators and electric heat plenum would be insulated with the same material.
- Z55 LINER-FIBERGLASS 1/2”**
1/2” fiberglass insulation, Default construction on models XG-TH, XG-TL, BP, XG-FCI, XG-FVL, XG-DD, XG-DH. Accessories such as sound attenuators and electric heat plenum would be insulated with the same material.
- Z82 SLIP AND DRIVE CONNECTION**
Slip and drive connection on the box discharge. Default construction on models TH, TL, BP, DD, and XG-FCQ. Boxes provided with hot water or electric reheat offer slip and drive connection on discharge as standard default construction.

- Z88 CONTROL AND REHEAT (ELECTRIC OR WATER) CONNECTIONS ON LEFT**
Control and reheat connections on left looking in the direction of air flow. Default construction on models XG-FCI, XG-FCI, XG-FCQ, XG-FVA, XG-FVL.
- Z91 CONTROL AND REHEAT (ELECTRIC OR WATER) CONNECTIONS ON RIGHT**
Control and reheat connections on right looking in the direction of air flow. Default construction on models XG-TH, XG-TL, XG-BP, XG-SR, XG-RT.
- Z94 COLD DUCT ON RIGHT**
Cold duct on the right looking in the direction of airflow. Default construction on models XG-DD, XG-DH, and XG-DS.

ELECTRIC HEAT OPTION DESCRIPTIONS

STANDARD CONSTRUCTION OR FACTORY USED ONLY

ZA1D - DISCONNECTING BREAK MAGNETIC CONTRACTORS PER STEP

This magnetic contactor is our standard offering, one per step or one for SSR. All ungrounded (hot) conductors are broken when contactor opens. Used with all voltages and phases.

ZA3D - DISCONNECTING BREAK BACKUP MAGNETIC CONTACTOR PER HEATER

This magnetic load carrying contactor is our standard offering, one per heater. This contactor remains closed as long as power is present and the “manual reset secondary high limit switch” has not tripped. Used with all voltages and phases. This can be used with ZA1D or A2D.

ZB1 - TRANSFORMER NON-FUSED

Step down transformer, primary voltage matches heater voltage, secondary is 24Vac. This is standard construction on all electric heat applications.

ZP3 - STANDARD HEATER CONTROL ENCLOSURE

Standard electric heat control enclosure.

F1 - INTERLOCK FAN CONTROL RELAY

Standard construction on fan powered boxes. Prevents the electric heat from energizing when the signal to energize the fan is not present from the controller. No option is available to replace this.

NO CODE - PRIMARY AUTOMATIC RESET HIGH TEMPERATURE LIMIT

Standard construction on all boxes. Primary high limit temperature cut off switch. Automatically resets after it is tripped.

NO CODE - BACKUP MANUAL RESET HIGH TEMPERATURE LIMIT

Standard construction on all boxes. Backup high temperature cut off switch. Must be manually reset after it is tripped.

NO CODE - TERMINAL BLOCK FOR FIELD LINE WIRING

Standard construction on all boxes. Used to land field line wires in the electric heat enclosure. Not used if D1 is chosen because the field wire will land at the door interlocking non-fused line disconnect switch.

S2 - NEUTRAL TERMINAL

Factory use only. Our factory will decide when and when not to use a neutral terminal, this option cannot be selected by the customer. Provided for fan only when line voltage does not match motor voltage. All domestic 277 and 120 volt motors need a neutral. This neutral terminal is not needed if option D1, door interlocking non-fused line disconnect switch, is specified. Usually required on all international orders.

(continued)

OPTIONS CUSTOMER CAN SELECT

A2D - DISCONNECTING BREAK MERCURY CONTACTORS PER STEP

Option instead of ZA1D. Silent operation. Mercury contactor, one per step or one for SSR. All ungrounded (hot) conductors are broken when contactor opens. Used with all voltages and phases.

C2 - FUSING PER STEP

Fuses are provided for each step of the heater, not to exceed 125% of amps per step. These fuses are located between the heater elements and the backup contactor and protect the internal wiring and components from the heater elements. These fuses can only be used on single phase heaters. The unbalanced nature of our three phase heaters does not permit this fuse option or any fuse option for three phase heaters.

C3 - LINE DISCONNECT FUSING

Line disconnect fusing protects the internal wiring and components within the heater control enclosure from the line voltage entering the enclosure. Maximum load of 48 AMPS. Available on all voltages and phases. Can be used with or without option D1 - door interlocking non-fused line disconnect switch.

D1 - DOOR INTERLOCKING NON-FUSED LINE DISCONNECT SWITCH

When turned off, disconnects power to the terminal whenever the control enclosure door is opened. Effective with single point power connection. If the fan motor voltage is different than the supply voltage, a dual point power option 108, should be specified to work with the heater disconnect to de-energize both power sources.

P1 - INSULATED HEATER CONTROL ENCLOSURE

The outside, backside of the control enclosure is insulated with 1" fiberglass insulation to reduce the possibility of condensation forming inside the control cabinet. Option instead of ZP3.

P2 - DUST TIGHT HEATER CONTROL ENCLOSURE

Control cabinet is sealed and door is gasketed to eliminate the possibility of dust entering the cabinet. When Chicago Code (option 75) is required, Option P2 should always be chosen as well. Option instead of ZP3.

G - AIR PRESSURE SWITCH

Standard on single duct with electric heat and is optional on fan boxes with electric heat. (Option G is for fan powered boxes with electric heat while option 46 is for fan powered boxes without electric heat.)

The air flow switch provides proof of airflow between the heater and the fan, the heater will not energize unless positive pressure in the duct is present. This is wired in series with the auto reset limit switch and the primary contactor. Requires a minimum of 0.08" WC total (static and velocity) pressure.

PL - DUST TIGHT HEATER CONTROL ENCLOSURE

- A. Standard application provides indication that operating line voltage is available to the heater.
- B. Other applications available. The customer must specify what is needed:
 - a. Indication as to the number of steps that are energized.
 - b. Indication that the air pressure switch is open.
 - c. Indication that the backup contactor is closed and the auto high limit is open.
- C. This used to be option "K".

B2 - TRANSFORMER WITH FUSED PRIMARY

Fused over current protection on the primary side of the transformer. Primary voltage matches heater voltage, secondary is 24Vac. Option instead of ZB1.

B3 - TRANSFORMER WITH FUSED SECONDARY

Fused over current protection on the secondary side of the transformer. Primary voltage matches heater voltage, secondary is 24Vac. Option instead of ZB1.

B4 - TRANSFORMER WITH BOTH FUSED PRIMARY AND SECONDARY

Fused over current protection on both the primary and secondary sides of the transformer. Primary voltage matches heater voltage, secondary is 24Vac. Option instead of ZB1.

N2A - SSR CONTROLLER 4-20 MA SIGNAL

100% proportional Solid State Relay control requiring a 0-20 or 4-20 mA signal provided by the damper controller. Preference can be switched on SSR control board. The wiring diagram includes a chart and instructions for settings.

N2B - SSR CONTROLLER 2-10 VDC SIGNAL

100% proportional Solid State Relay control requiring a 0-10 or 2-10 volt DC signal provided by the damper controller. Preference can be switched on SSR control board. The wiring diagram includes a chart and instructions for settings.

N3A - SSR CONTROLLER - PWM - PULSE WIDTH MODULATION AC

100% proportional solid state control which accepts a 24 VAC pulsed input signal provided by the damper controller. PWM cycles the heater on/off depending on the amount of heat required by the room.