



# XG-TL-500 LOW PROFILE SINGLE DUCT AIR TERMINAL UNIT

## SPECIFIABLE FEATURES

- Maximum height of units is 12 1/2".
- 22 ga. galvanized steel casing, mechanically sealed for low leakage construction.
- Damper construction of double layer 18 gauge equivalent with integral blade seal.
- Metal inlet flow sensor with extra balancing taps.
- Butt welded round primary inlet duct to minimize leakage.

INDEX OF SECTIONS	PAGE
Dimensional Data	4
AHRI Certified Rating Points	9
Sound Performance Data	10
Casing Leakage / Damper Leakage	12
Certifications and Standards	12
Hot Water Coil Selection Data	13
Hot Water Coils	16
Electric Heat	17
Electric Heater Capacities	18
Sound Attenuators	19
Recommended Min/Max Airflow Ranges	19
Control Sequence Offerings	20



# XG-TL-500 LOW PROFILE SINGLE DUCT AIR TERMINAL UNIT

The Greenheck XG-TL-500 is the simplest and most widely used VAV terminal unit used for low profile applications. Its basic components are an insulated sheet metal box, round inlet damper, flow measuring device and rectangular outlet. The unit is served by a central air handler and modulates the amount of 'primary' cooling air to the space between a minimum set point and the design airflow.

When necessary, the Greenheck XG-TL-500 can be provided with a heating coil on the discharge of the unit to provide for reheat. The unit has a maximum height of 12 1/2".

## STANDARD FEATURES

- XG-TL-500 is available in 10 unit sizes to handle 30–4350 CFM.
- Variable or constant volume applications.
- 22 ga. galvanized steel casing, mechanically sealed for low leakage
- Mechanically fastened damper assembly is double layer, 18 gauge equivalent, galvanized steel with integral blade seal. (<1% at 3.0" wg static pressure).
- Optional factory calibrated controls to meet all control strategies.
- Multi-quadrant, averaging flow sensor for highly accurate (+/-5%) flow readings with varying inlet duct configurations after certified balancer has balanced terminal
- Externally accessible, steel balancing taps.
- External control cabinet with offset mounting plate is standard.
- 3-beaded inlet connection tube for added rigidity and secure flex duct connections.
- 1/2" thick, dual density (1.5lb / ft<sup>3</sup> min.) fiberglass insulation with edges coated. Meets NFPA 90A and UL 181.
- Rectangular discharge with slip and drive cleat duct connection.
- Independently tested and certified laboratory performance data.
- Full range of options and accessories available (heating coils, disconnects, attenuators, etc.).
- Full range of liners / insulation available.

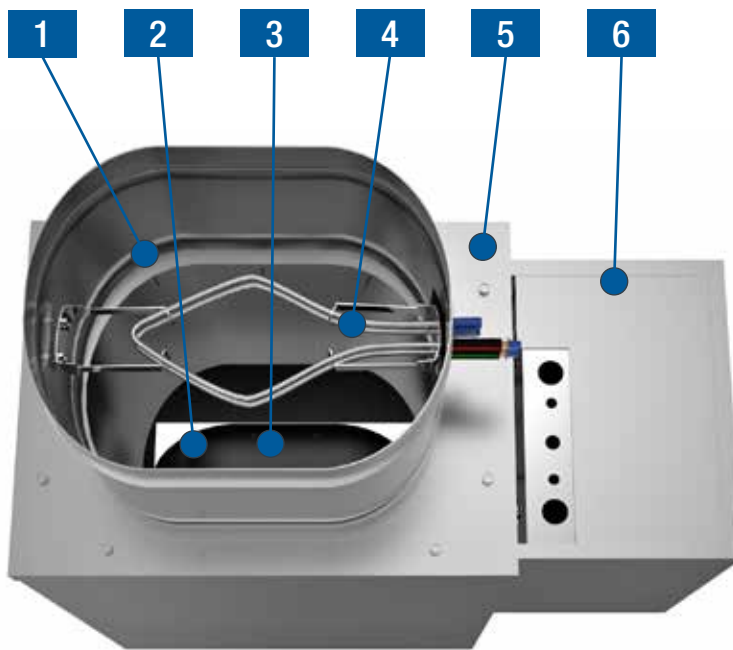

# XG-TL-500 LOW PROFILE SINGLE DUCT AIR TERMINAL UNIT

## FEATURES AND BENEFITS

- 1** Continuous welded primary inlet duct to minimize leakage with three stiffening beads for added rigidity.
- 2** Damper construction of double layer 18 gauge equivalent with integral blade seal.
- 3** Damper rotates in a self-lubricating, long life, low friction thermoplastic bearing.
- 4** All metal constructed inlet flow sensor with extra balancing taps.
- 5** Galvanized steel casing, mechanically sealed for low leakage construction.
- 6** NEMA TYPE 1 rated control enclosure with stand-off to prevent penetration of casing standard on all terminal units.
- 7** All XG-TL-500 terminal units are AHRI certified and shipped with the AHRI seal.

## XG-TL-500 LOW PROFILE SINGLE DUCT AIR TERMINAL UNIT, COOLING ONLY

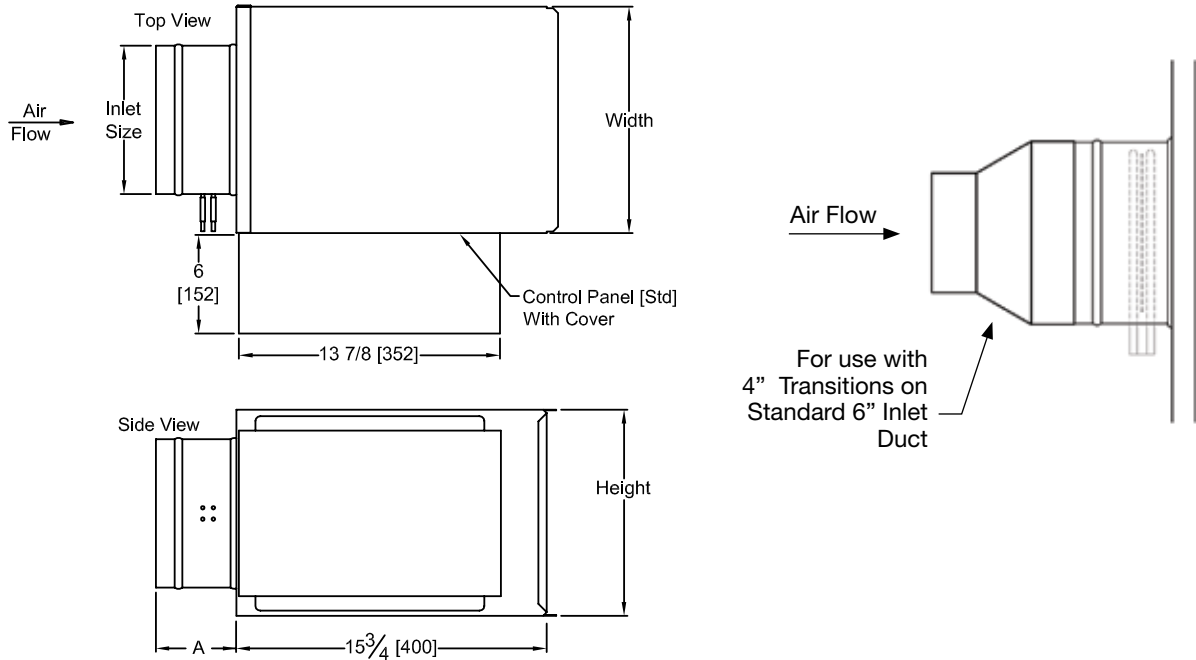

The standard location for control panel is Right Hand on Model XG-TL.

Looking in the direction of airflow, the control panel is on the right.

The control panel will overhang the top and bottom of unit size 4, 5, and 6, 1" (25.4 mm).

Control Panel Mounting Surface width by height is 13 7/8" x 9 3/4".

Unit Sizes 12-OV, 14-OV & 16-OV have flat oval inlet ducts.

Unit Size	Inlet Size		A		Width		Height		Unit wt.	
	in.	mm.	in.	mm.	in.	mm.	in.	mm.	lb.	kg.
4	3 7/8	99	10	254	12	305	8	203	12	5
5	4 7/8	124	5	127	12	305	8	203	12	5
6	5 7/8	149	5	127	12	305	8	203	12	5
7	6 7/8	174	5	127	12	305	10	254	15	7
8	7 7/8	200	5	127	12	305	10	254	15	7
9	8 7/8	225	5	127	14	356	12 1/2	318	18	8
10	9 7/8	251	5	127	14	356	12 1/2	318	18	8
12-OV	13 x 9 7/8	330 x 251	5	127	18	457	12 1/2	318	23	10
14-OV	16 1/4 x 9 7/8	413 x 251	5	127	24	610	12 1/2	318	26	12
16-OV	19 3/8 x 9 7/8	492 x 251	5	127	28	711	12 1/2	318	30	14

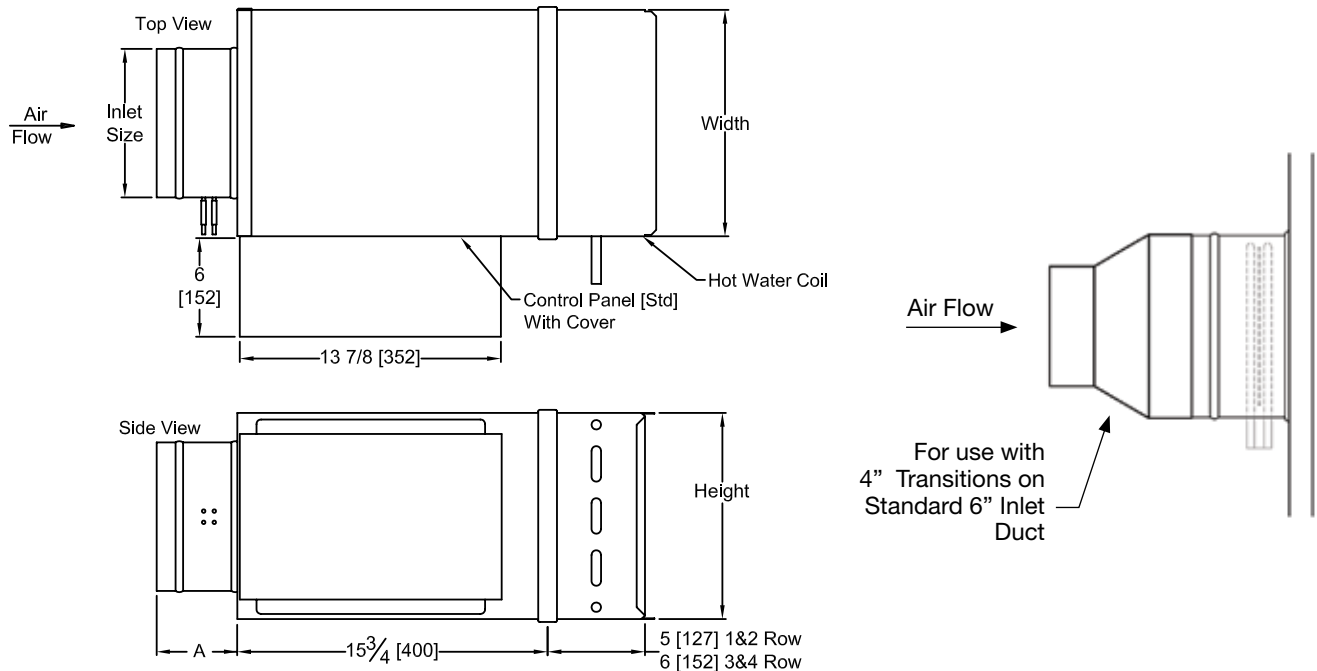
**XG-TL-500 LOW PROFILE SINGLE DUCT AIR TERMINAL UNIT WITH HOT WATER COIL**

The standard location for control panel is Right Hand on Model XG-TL.

Looking in the direction of airflow, the control panel is on the right.

The control panel will overhang the top and bottom of unit size 4, 5, and 6, 1" (25.4 mm).

Control Panel Mounting Surface width by height is 13 7/8" x 9 3/4".

Unit Sizes 12-OV, 14-OV & 16-OV have flat oval inlet ducts.

Unit Size	Inlet Size		A		Width		Height		Unit wt.							
	in.	mm.	in.	mm.	in.	mm.	in.	mm.	1 Row		2 Row		3 Row		4 Row	
									lb.	kg.	lb.	kg.	lb.	kg.	lb.	kg.
4	3 7/8	99	10	254	12	305	8	203	16.5	8	17.5	8	20	9	20.25	9
5	4 7/8	124	5	127	12	305	8	203	16.5	8	17.5	8	20	9	20.25	9
6	5 7/8	149	5	127	12	305	8	203	16.5	8	17.5	8	20	9	20.25	9
7	6 7/8	174	5	127	12	305	10	254	20	9	22.75	10	26.25	12	26.5	12
8	7 7/8	200	5	127	12	305	10	254	20	9	22.75	10	26.25	12	26.5	12
9	8 7/8	225	5	127	14	356	12 1/2	318	24.5	11	27.5	13	33.75	15	34.75	16
10	9 7/8	251	5	127	14	356	12 1/2	318	24.5	11	27.5	13	33.75	15	34.75	16
12-OV	13 x 9 7/8	300 x 251	5	127	18	457	12 1/2	318	31.5	14	35.5	16	42.25	19	44.5	20
14-OV	16 1/4 x 9 7/8	413 x 251	5	127	24	610	12 1/2	318	35	16	41.5	19	50	23	51.75	24
16-OV	19 3/8 x 9 7/8	492 x 251	5	127	28	711	12 1/2	318	41.5	19	47.25	21	55.25	25	58.5	27

**XG-TL-500 LOW PROFILE SINGLE DUCT AIR TERMINAL UNIT WITH INTEGRAL ATTENUATOR AND ELECTRIC HEAT**

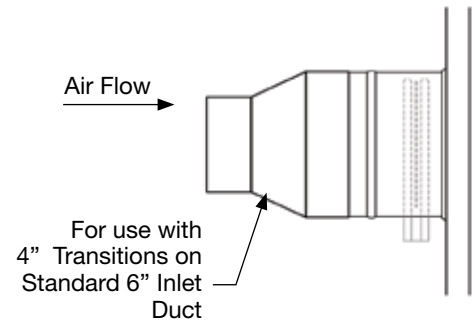
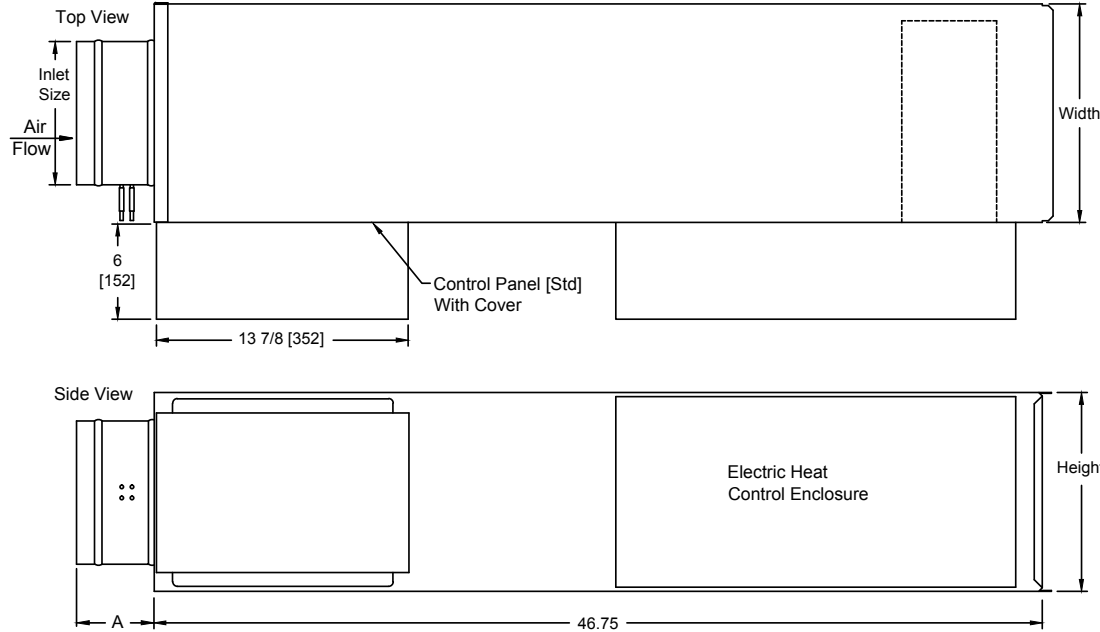

The standard location for control panel is Right Hand on Model XG-TL. Looking in the direction of airflow, the control panel is on the right.

The control panel will overhang the top and bottom of unit size 4, 5, and 6, 1" (25.4 mm). Control Panel Mounting Surface width by height is 13 7/8" x 9 3/4".

Unit Sizes 12-OV, 14-OV & 16-OV have flat oval inlet ducts.

Unit Size	Inlet Size		A		Width		Height		Unit wt.	
	in.	mm.	in.	mm.	in.	mm.	in.	mm.	lb.	kg.
4	3 7/8	99	10	254	12	305	8	203	39	18
5	4 7/8	124	5	127	12	305	8	203	39	18
6	5 7/8	149	5	127	12	305	8	203	39	17
7	6 7/8	174	5	127	12	305	10	254	43	20
8	7 7/8	200	5	127	12	305	10	254	43	20
9	8 7/8	225	5	127	14	356	12 1/2	318	50	23
10	9 7/8	251	5	127	14	356	12 1/2	318	50	23
12-OV	13 x 9 7/8	330 x 251	5	127	18	457	12 1/2	318	59	27
14-OV	16 1/4 x 9 7/8	413 x 251	5	127	24	610	12 1/2	318	67	30
16-OV	19 3/8 x 9 7/8	492 x 251	5	127	28	711	12 1/2	318	77	35

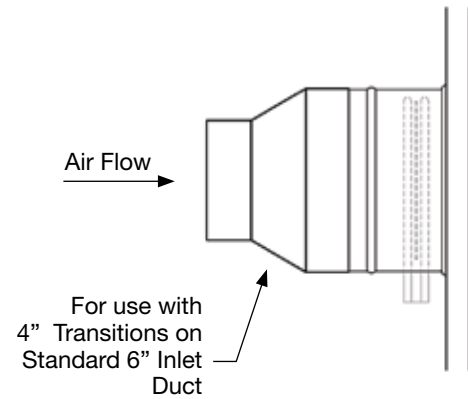
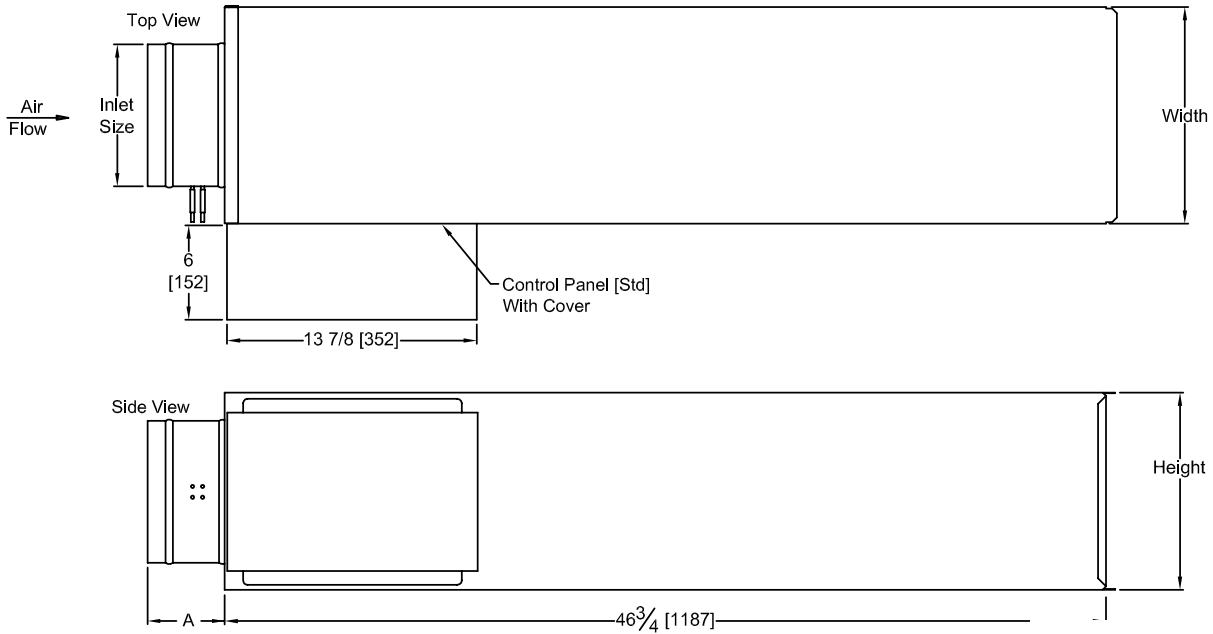
**XG-TL-500 LOW PROFILE SINGLE DUCT AIR TERMINAL UNIT  
 WITH INTEGRAL ATTENUATOR**

The standard location for control panel is Right Hand on Model XG-TL. Looking in the direction of airflow, the control panel is on the right.

The control panel will overhang the top and bottom of unit size 4, 5, and 6, 1" (25.4 mm).

Control Panel Mounting Surface width by height is 13 7/8" x 9 3/4".

Unit Sizes 12-OV, 14-OV & 16-OV have flat oval inlet ducts.

Unit Size	Inlet Size		A		Width		Height		Unit wt.	
	in.	mm.	in.	mm.	in.	mm.	in.	mm.	lb.	kg.
4	3 7/8	99	10	254	12	305	8	203	24	10
5	4 7/8	124	5	127	12	305	8	203	24	10
6	5 7/8	149	5	127	12	305	8	203	24	10
7	6 7/8	174	5	127	12	305	10	254	28	12
8	7 7/8	200	5	127	12	305	10	254	28	12
9	8 7/8	225	5	127	14	356	12 1/2	318	34	15
10	9 7/8	251	5	127	14	356	12 1/2	318	34	15
12-OV	13 x 9 7/8	330 x 251	5	127	18	457	12 1/2	318	41	18
14-OV	16 1/4 x 9 7/8	413 x 251	5	127	24	610	12 1/2	318	47	21
16-OV	19 3/8 x 9 7/8	492 x 251	5	127	28	711	12 1/2	318	54	24

**(THIS PAGE INTENTIONALLY LEFT BLANK)**



**XG-TL-500 AHRI CERTIFIED RATING POINTS**

**RADIATED SOUND**

Power Levels @ 1.5" w.g. ΔPs

Unit Size	CFM	Min ΔPs	Octave Band					
			2	3	4	5	6	7
4	150	0.03	48	41	32	28	24	20
5	250	0.06	54	46	42	34	31	30
6	400	0.10	58	53	49	44	41	36
7	550	0.06	59	53	46	41	34	31
8	700	0.09	62	56	49	44	36	32
9	900	0.02	58	57	51	43	38	33
10	1100	0.04	59	60	53	46	40	35
12-OV	1500	0.10	64	59	55	47	42	37
14-OV	2000	0.11	62	58	51	44	37	34
16-OV	2400	0.09	65	62	57	51	48	45

**DISCHARGE SOUND**

Power Levels @ 1.5" w.g. ΔPs

Unit Size	CFM	Min ΔPs	Octave Band					
			2	3	4	5	6	7
4	150	0.03	63	58	54	49	43	37
5	250	0.06	65	60	56	50	46	41
6	400	0.10	66	63	59	52	48	48
7	550	0.06	73	68	60	57	53	50
8	700	0.09	75	71	63	60	56	52
9	900	0.02	71	68	62	58	54	51
10	1100	0.04	72	70	64	59	56	52
12-OV	1500	0.10	73	72	68	63	57	54
14-OV	2000	0.11	72	68	61	60	60	59
16-OV	2400	0.09	79	76	72	68	63	58

**PERFORMANCE NOTES**

- 1) Radiated sound is the noise transmitted through the unit casing
- 2) Discharge sound is noise emitted from unit discharge into downstream ductwork
- 3) Sound power levels expressed in decibels, (dB) re 10<sup>-12</sup> Watts
- 4) Min ΔPs is the min. operating pressure requirement of the unit with the damper full open and is the static pressure drop from the unit inlet to the unit discharge
- 5) Performance data based on laboratory tests conducted in accordance with ASHRAE 130-2016 and AHRI 880-2017
- 6) Discharge sound power levels include duct end reflection corrections per AHRI Standard 880-2017
- 7) Sound performance based on units lined with standard dual density fiberglass insulation

**RADIATED SOUND MODEL XG-TL**

		OCTAVE BAND SOUND POWER, Lw, dB																												
Unit Size	CFM	Min ΔPs	ΔPs = 0.50 in. wg.							ΔPs = 1.0 in. wg.							ΔPs = 1.5 in. wg.							ΔPs = 3.0 in. wg.						
			2	3	4	5	6	7	NC	2	3	4	5	6	7	NC	2	3	4	5	6	7	NC	2	3	4	5	6	7	NC
4	50	0.01	41	32	19	19	15	7	<15	43	34	21	21	17	9	<15	44	35	22	22	18	11	<15	45	38	25	24	23	18	<15
	100	0.02	43	34	23	22	19	13	<15	45	36	25	24	21	15	<15	46	37	26	24	22	17	<15	47	40	29	27	27	24	<15
	150	0.03	46	36	29	26	21	16	<15	48	40	31	28	23	18	<15	48	41	32	28	24	20	21	50	44	35	31	29	27	<15
	200	0.04	49	41	35	29	23	18	<15	51	43	37	31	25	20	22	52	44	38	32	26	22	31	53	47	41	34	31	29	<15
	250	0.06	51	43	39	32	28	26	<15	53	45	41	34	30	28	29	54	46	42	34	31	30	35	55	49	45	37	36	37	19
5	150	0.03	46	38	29	26	21	16	<15	48	40	31	28	23	18	<15	48	41	32	28	24	20	<15	50	44	35	31	29	27	<15
	200	0.04	49	41	35	29	23	18	<15	51	43	37	31	25	20	<15	52	44	38	32	26	22	<15	53	47	41	34	31	29	<15
	250	0.06	51	43	39	32	28	26	<15	53	45	41	34	30	28	<15	54	46	42	34	31	30	15	55	49	45	37	36	37	19
	300	0.07	53	46	43	35	32	30	16	55	48	45	37	34	32	19	56	49	46	38	35	34	20	57	52	49	40	40	41	23
	350	0.09	54	48	46	38	35	33	20	56	50	48	39	37	35	22	57	51	48	40	38	37	22	58	53	51	42	42	42	25
6	200	0.04	49	41	35	29	23	18	<15	51	43	37	31	25	20	<15	52	44	38	32	26	22	<15	53	47	41	34	31	29	<15
	300	0.07	53	46	43	35	32	30	16	55	48	45	37	34	32	19	56	49	46	38	35	34	20	57	52	49	40	40	41	23
	400	0.10	55	50	46	41	38	32	20	57	52	48	43	40	34	22	58	53	49	44	41	36	23	59	56	52	46	46	43	26
	500	0.14	57	53	48	44	40	34	22	59	55	50	46	42	36	24	60	56	51	46	43	38	25	61	59	54	49	48	45	29
	600	0.15	58	54	49	45	41	35	23	60	56	51	47	43	37	25	60	57	52	47	44	39	26	61	60	55	50	49	46	30
7	350	0.03	52	41	34	26	21	19	<15	56	47	42	36	28	24	18	56	48	43	38	32	28	18	57	49	46	43	40	38	20
	450	0.04	52	42	35	29	22	19	<15	56	49	42	37	30	25	18	57	50	45	40	34	30	19	58	53	50	46	42	40	24
	550	0.06	54	44	36	32	24	20	15	58	51	42	38	30	26	20	59	53	46	41	34	31	21	60	57	52	48	42	40	26
	650	0.08	55	45	38	34	26	20	16	60	52	44	39	32	28	22	61	55	48	43	36	32	24	62	60	55	50	44	41	30
	750	0.10	56	47	41	36	28	22	18	62	54	46	40	34	29	25	63	57	50	44	37	33	26	66	62	57	52	44	42	32
8	400	0.04	52	42	34	28	22	19	<15	56	48	42	36	29	24	18	56	49	44	39	33	29	18	58	51	48	44	41	39	22
	550	0.06	54	44	36	32	24	20	15	58	51	42	38	30	26	20	59	53	46	41	34	31	21	60	57	52	48	42	40	26
	700	0.09	56	46	40	35	27	21	18	61	53	45	40	33	28	24	62	56	49	44	36	32	25	64	61	56	51	44	41	31
	850	0.11	58	49	43	38	30	24	20	63	54	47	42	36	31	26	64	58	51	45	39	34	28	68	64	58	52	46	42	35
	1000	0.13	60	52	46	42	34	27	22	65	57	50	45	39	33	29	66	60	53	48	42	36	30	70	66	60	54	47	42	37
9	500	0.01	46	45	34	28	25	21	<15	51	50	44	34	30	24	18	55	51	45	38	34	29	19	59	52	47	44	41	40	21
	700	0.01	48	47	38	32	27	22	<15	52	52	46	38	32	26	20	56	54	49	41	36	31	23	62	59	53	47	44	41	29
	900	0.02	48	48	41	35	28	23	15	54	54	48	40	34	27	22	58	57	51	43	38	33	26	64	64	58	50	46	44	35
	1100	0.04	51	50	44	38	30	24	18	55	55	49	41	35	29	24	59	60	53	46	40	35	30	65	68	61	53	48	47	39
	1300	0.06	54	54	47	41	32	26	22	58	56	50	42	36	30	25	62	61	54	47	41	37	31	68	70	62	55	50	49	41
10	700	0.01	48	47	38	32	27	22	<15	52	52	46	38	32	26	20	56	54	49	41	36	31	23	62	59	53	47	44	41	29
	900	0.02	48	48	41	35	28	23	15	54	54	48	40	34	27	22	58	57	51	43	38	33	26	64	64	58	50	46	44	35
	1100	0.04	51	50	44	38	30	24	18	55	55	49	41	35	29	24	59	60	53	46	40	35	30	65	68	61	53	48	47	39
	1300	0.06	54	54	47	41	32	26	22	58	56	50	42	36	30	25	62	61	54	47	41	37	31	68	70	62	55	50	49	41
	1500	0.08	56	56	49	42	36	20	25	61	58	51	44	38	32	28	66	62	55	48	43	39	32	72	70	63	56	50	50	41
12-0V	700	0.02	56	45	37	30	26	20	18	56	51	45	36	30	25	20	59	53	48	41	35	30	22	61	58	55	50	45	42	30
	1100	0.05	57	49	41	34	30	24	19	60	54	49	40	33	28	23	61	57	53	45	39	33	28	64	64	62	56	49	45	37
	1500	0.10	58	50	46	39	36	28	20	62	55	51	43	38	32	25	64	59	55	47	42	37	30	67	68	64	57	50	45	39
	1900	0.15	61	53	50	43	39	32	24	63	57	53	46	42	36	28	65	61	57	50	45	39	32	69	70	65	58	51	46	41
	2300	0.19	63	56	55	48	44	37	30	65	60	57	50	46	41	32	67	65	61	53	50	44	36	71	75	70	63	55	51	48
14-0V	1000	0.03	57	44	39	33	30	27	19	57	48	44	37	28	25	19	58	49	45	38	29	26	20	61	52	48	43	33	31	24
	1500	0.06	60	50	44	40	37	34	22	59	54	47	42	33	31	22	60	55	48	43	34	32	24	63	59	52	48	40	38	29
	2000	0.11	62	53	46	41	39	35	25	61	57	50	43	36	33	26	62	58	51	44	37	34	28	65	63	56	51	46	45	34
	2500	0.16	62	56	48	44	42	37	25	62	59	52	46	38	34	29	64	60	54	46	38	36	30	66	64	58	54	46	46	35
	3000	0.21	65	61	54	49	46	42	31	65	64	57	50	41	38	35	66	65	58	51	42	39	36	69	69	63	58	51	52	40
16-0V	1200	0.02	57	49	40	33	29	24	19	58	53	45	38	34	28	21	59	55	49	43	38	34	24	62	60	55	52	46	44	30
	1800	0.06	60	53	43	38	35	31	22	60	57	48	42	39	34	26	62	60	53	47	44	40	30	67	66	62	58	56	53	37
	2400	0.09	61	54	47	43	39	36	24	62	58	52	46	42	38	28	65	62	57	51	48	45	32	69	69	65	62	61	60	40
	3000	0.14	62	57	52	46	42	39	26	64	60	55	49	44	41	30	66	64	59	54	50	47	35	71	70	67	64	63	62	42
	3600	0.18	63	61	56	51	47	44	31	66	63	59	53	48	44	34	68	67	63	57	55	51	38	73	73	72	69	69	69	48

- AHRI certified data is highlighted while all other data are application ratings
- Radiated sound is the noise transmitted through the unit casing
- Sound power levels

DISCHARGE SOUND MODEL XG-TL

		OCTAVE BAND SOUND POWER, Lw, dB																												
Unit Size	CFM	Min ΔPs	ΔPs = 0.50 in. wg.							ΔPs = 1.0 in. wg.							ΔPs = 1.5 in. wg.							ΔPs = 3.0 in. wg.						
			2	3	4	5	6	7	NC	2	3	4	5	6	7	NC	2	3	4	5	6	7	NC	2	3	4	5	6	7	NC
4	50	0.01	59	47	39	35	29	22	<15	60	55	50	47	39	31	<15	61	56	51	48	40	32	16	64	59	52	51	43	35	20
	100	0.02	60	49	39	34	30	26	<15	61	56	52	47	40	34	16	62	57	53	48	41	35	18	65	60	54	51	44	38	21
	150	0.03	61	51	42	37	32	27	16	62	57	53	48	42	36	18	<b>63 58 54 49 43 37</b>	19	66	61	55	52	46	40	22					
	200	0.04	62	52	45	40	34	28	18	63	58	53	49	44	37	19	64	59	54	50	45	38	20	67	62	55	53	48	41	24
	250	0.06	63	54	47	42	36	32	19	64	59	55	49	45	40	20	65	60	56	50	46	41	21	68	63	59	53	49	44	25
5	150	0.03	61	51	42	37	32	27	16	62	57	53	48	42	36	18	63	58	54	49	43	37	19	66	61	55	52	46	40	22
	200	0.04	62	52	45	40	34	28	18	63	58	53	49	44	37	19	64	59	54	50	45	38	20	67	62	55	53	48	41	24
	250	0.06	63	54	47	42	36	32	19	64	59	55	49	45	40	20	<b>65 60 56 50 46 41</b>	21	68	63	59	53	49	44	25					
	300	0.07	64	56	51	45	38	34	16	64	61	57	50	46	43	19	65	62	58	51	47	44	20	68	65	61	54	50	47	24
	350	0.09	63	57	52	46	40	37	15	63	61	58	50	47	44	19	64	62	58	51	48	45	20	67	64	61	53	50	48	22
6	200	0.04	62	52	45	40	34	28	18	63	58	53	49	44	37	19	64	59	54	50	45	38	20	67	62	55	53	48	41	24
	300	0.07	64	56	51	45	38	34	16	64	61	57	50	46	43	19	65	62	58	51	47	44	20	68	65	61	54	50	47	24
	400	0.10	65	60	55	49	42	40	20	65	62	58	51	47	47	20	<b>66 63 59 52 48 48</b>	21	69	67	62	55	51	51	26					
	500	0.14	68	64	59	54	48	45	22	68	66	62	56	52	50	25	69	67	63	57	53	51	26	72	70	66	60	56	54	30
	600	0.15	68	66	60	56	50	47	25	68	67	63	58	54	50	26	70	68	64	59	54	52	28	72	71	67	62	57	54	31
7	350	0.03	65	58	49	44	39	34	18	69	65	58	54	50	46	24	69	65	58	54	50	48	24	70	66	58	58	54	52	25
	450	0.04	66	60	51	47	40	36	19	71	66	60	55	51	46	25	71	66	60	56	52	50	25	72	68	60	58	54	54	28
	550	0.06	68	62	53	50	42	38	21	72	68	60	57	52	48	28	<b>73 68 60 57 53 50</b>	28	74	69	60	60	56	55	29					
	650	0.08	70	64	55	52	44	40	24	74	70	62	59	54	49	30	74	70	62	59	55	52	30	76	72	62	61	58	56	32
	750	0.10	72	66	57	55	46	42	24	75	70	64	60	54	50	29	76	72	64	61	56	53	31	78	74	64	63	60	58	34
8	400	0.04	66	59	50	46	40	35	19	70	66	59	54	50	46	25	70	66	59	55	51	49	25	71	67	59	58	54	53	26
	550	0.06	68	62	53	50	42	38	21	72	68	60	57	52	48	28	73	68	60	57	53	50	28	74	69	60	60	56	55	29
	700	0.09	71	65	56	54	45	40	22	74	70	63	60	54	50	29	<b>75 71 63 60 56 52</b>	30	77	73	64	62	59	57	32					
	850	0.11	73	67	59	57	48	44	25	77	72	65	62	56	51	31	78	73	65	63	58	55	32	80	75	66	66	62	60	35
	1000	0.13	75	70	62	60	52	47	29	79	74	67	65	58	53	34	80	75	68	66	60	56	35	82	77	69	70	65	62	37
9	500	0.01	60	58	48	45	36	34	15	65	64	56	53	48	44	22	66	64	58	54	49	46	22	68	66	60	58	54	52	25
	700	0.01	64	60	52	48	40	38	16	68	66	59	55	50	47	24	69	67	61	56	51	49	25	71	69	64	60	56	53	28
	900	0.02	66	62	54	50	41	40	19	70	68	61	57	53	50	26	<b>71 68 62 58 54 51</b>	26	73	70	66	61	57	54	29					
	1100	0.04	68	64	57	53	45	43	21	72	69	63	58	55	52	28	72	70	64	59	56	52	29	74	72	68	62	59	55	31
	1300	0.06	70	68	60	57	50	48	26	74	72	66	62	56	54	31	75	72	67	62	58	54	31	78	74	70	64	62	59	34
10	700	0.01	64	60	52	48	40	38	16	68	66	59	55	50	47	24	69	67	61	56	51	49	25	71	69	64	60	56	53	28
	900	0.02	66	62	54	50	41	40	19	70	68	61	57	53	50	26	71	68	62	58	54	51	26	73	70	66	61	57	54	29
	1100	0.04	68	64	57	53	45	43	21	72	69	63	58	55	52	28	<b>72 70 64 59 56 52</b>	28	74	72	68	62	59	55	31					
	1300	0.06	70	68	60	57	50	48	26	74	72	66	62	56	54	31	75	72	67	62	58	54	31	78	74	70	64	62	59	34
	1500	0.08	73	71	62	60	54	52	30	77	75	68	66	60	56	35	77	75	68	66	60	57	35	80	78	72	68	64	61	38
12-0V	700	0.02	64	60	50	44	34	32	16	67	65	58	52	43	40	22	69	67	61	57	49	45	25	72	71	65	64	61	56	30
	1100	0.05	67	64	54	50	41	39	21	69	68	62	55	48	45	26	71	71	65	60	53	49	30	74	75	71	69	64	59	35
	1500	0.10	71	68	60	56	48	46	26	71	70	64	59	54	50	29	<b>73 72 68 63 57 54</b>	31	77	78	74	72	66	62	38					
	1900	0.15	73	71	64	61	55	52	30	73	72	66	62	58	55	31	76	74	69	65	60	58	34	80	79	76	73	67	63	39
	2300	0.19	76	76	68	66	62	58	36	75	76	70	66	64	60	36	78	79	73	69	65	61	39	82	83	80	77	72	67	44
14-0V	1000	0.03	58	48	43	39	40	40	<15	64	54	49	47	48	48	<15	66	56	51	49	50	50	16	69	59	54	53	54	54	20
	1500	0.06	61	57	50	47	48	48	<15	67	63	56	55	56	56	20	69	65	58	57	58	58	22	72	68	61	61	62	62	26
	2000	0.11	64	60	53	50	50	49	16	70	66	59	58	58	57	24	<b>72 68 61 60 60 59</b>	26	75	71	64	64	64	63	30					
	2500	0.16	66	62	56	54	52	52	19	72	68	62	62	60	60	26	74	70	64	64	62	62	29	77	72	68	68	66	66	31
	3000	0.21	70	68	65	61	60	59	26	74	72	69	67	66	66	31	76	74	70	68	68	67	34	79	76	73	72	71	72	36
16-0V	1200	0.02	69	66	60	55	49	44	24	71	70	65	60	53	49	29	72	71	67	64	58	53	30	73	74	71	69	66	61	34
	1800	0.06	74	71	64	59	54	49	30	75	73	69	63	57	52	32	77	75	71	67	61	55	35	79	79	75	76	70	65	39
	2400	0.09	77	73	68	62	57	54	32	77	75	70	64	59	55	35	<b>79 76 72 68 63 58</b>	36	82	80	76	76	71	65	40					
	3000	0.14	77	74	70	64	59	56	34	78	75	71	65	61	57	35	80	77	73	68	64	60	37	83	81	78	76	72	66	41
	3600	0.18	79	78	73	67	62	60	38	80	79	74	68	64	60	39	82	81	76	72	67	63	41	86	84	82	80	76	70	45

1) AHRI certified data is highlighted while all other data are application ratings  
 2) Discharge sound is noise emitted from unit discharge into downstream ductwork  
 3) Sound power levels expressed in decibels, (dB) re 10<sup>-12</sup> Watts  
 4) Min ΔPs is the min. operating pressure requirement of the unit with the damper full open and is the static pressure drop from the unit inlet to the unit discharge  
 5) Performance data based on laboratory tests conducted in accordance with ASHRAE 130-2016 and AHRI 880-2017  
 6) NC values are calculated using attenuation credits outlined in AHRI 885-2008 Appendix E  
 7) Blank spaces indicate Minimum Ps if unit exceeds the ΔPs across the unit  
 8) Sound performance based on units lined with standard dual density fiberglass insulation  
 9) Discharge sound power levels include duct end reflection corrections per AHRI Standard 880-2017  
 10) Size 12, 14, and 16 are flat ovals and the AHRI rating points are calculated from multiplying the inlet area, ft<sup>2</sup>, by 2000 fpm per AHRI Standard 880-2017

**XG-TL-500 STANDARD CONSTRUCTION CASING AND DAMPER LEAKAGE**

Standard Construction				
Inlet Diameter	Static Pressure " w.g.	Maximum Airflow	Max Casing Leakage	Max Damper Leakage
4	3	300	5	5
5	3	375	5	5
6	3	540	5	5
7	3	760	7	7
8	3	990	9	9
9	3	1250	12	12
10	3	1640	16	16
12	3	2350	22	22
14	3	3250	32	32
16	3	4100	41	41
20	3	6430	64	64
24	3	7270	72	72

**PERFORMANCE NOTES**

- 1) Leakage testing conducted in accordance with ASHRAE 130-2016
- 2) Per ASHRAE Standard 130-2016 "terminal casing leakage: the amount of the air in ft<sup>3</sup>/min (L/s) leaking from the terminal unit at a given inlet pressure with the outlet(s) and inlet(s) blocked and with the damper/valve fully opened"
- 3) Per ASHRAE Standard 130-2016 "terminal damper leakage: the amount of air in ft<sup>3</sup>/min (L/s) leaking through a fully closed damper/valve of a supply/exhaust terminal unit at a given inlet pressure"opened"
- 4) Casing and Damper leakage shall not exceed 1% of the maximum rated airflow at 3" w.g.
- 5) 4" and 5" inlets are built with 6" casings

**CERTIFICATIONS AND STANDARDS**

- Units tested per ASHRAE Standard 130-2016.
- All model sizes certified in accordance with AHRI 880-2017 certification program.
- ETL listed to meet requirements of UL 1995 and CSA 236.
- Dual-density fiberglass insulation meets UL 181 and NFPA 90A/90B.
- Insulation meets ASHRAE 62.1 requirements for resistance to mold growth and erosion.
- Hot water coils are manufactured in accordance to AHRI Standard 410.

**XG-TL-500 HOT WATER COILS MBH SELECTION DATA – IMPERIAL UNITS**

Unit Size	Rows	Connection OD (in)	GPM	Head Loss (ft-H <sub>2</sub> O)	CFM							
					100	200	300	350	400	450	500	600
4 5 6	1	0.625	1	0.46	5.1	7.2	8.6	9.1	9.6	10.0	10.3	11.0
			2	1.76	5.4	7.8	9.5	10.1	10.7	11.2	11.7	12.5
			3	3.86	5.5	8.1	9.8	10.5	11.2	11.7	12.2	13.2
			4	6.73	5.6	8.2	10.0	10.7	11.4	12.0	12.6	13.5
			Airside Ps		0.01	0.04	0.07	0.10	0.12	0.15	0.18	0.24
	2	0.875	1	0.12	7.5	11.1	13.4	14.3	15.0	15.7	16.3	17.3
			2	0.46	8.1	12.5	15.5	16.8	17.8	18.8	19.7	21.2
			4	1.75	8.4	13.4	17.0	18.4	19.8	21.0	22.1	24.1
			6	3.84	8.5	13.7	17.5	19.1	20.6	21.9	23.1	25.2
			Airside Ps		0.03	0.08	0.16	0.21	0.26	0.32	0.38	0.51
	3	0.875	1	0.07	8.9	13.2	15.9	16.8	17.7	18.4	19.0	20.0
			2	0.28	9.6	15.2	19.1	20.6	21.9	23.1	24.1	25.9
			4	1.09	10.0	16.5	21.3	23.2	25.0	26.6	28.0	30.5
			6	2.44	10.2	17.0	22.2	24.3	26.3	28.0	29.7	32.5
			Airside Ps		0.04	0.12	0.24	0.31	0.39	0.47	0.56	0.77
	4	0.875	1	0.05	9.7	14.5	17.4	18.4	19.3	20.1	20.7	21.7
			2	0.20	10.5	17.0	21.4	23.2	24.7	26.0	27.1	29.1
			4	0.79	10.9	18.6	24.2	26.6	28.7	30.6	32.3	35.3
			6	1.77	11.1	19.2	25.3	28.0	30.4	32.5	34.5	38.0
			Airside Ps		0.05	0.16	0.32	0.41	0.52	0.63	0.75	1.02

Unit Size	Rows	Connection OD (in)	GPM	Head Loss (ft-H <sub>2</sub> O)	CFM							
					500	600	700	800	1000	1200	1400	1600
7 8	1	0.625	1	0.63	12.1	12.9	13.5	14.1	15.1	15.9	16.5	17.1
			2	2.39	13.7	14.7	15.6	16.4	17.7	18.8	19.7	20.5
			3	5.24	14.3	15.4	16.4	17.3	18.8	20.1	21.1	22.1
			4	9.14	14.7	15.9	16.9	17.9	19.5	20.8	21.9	22.9
			Airside Ps		0.11	0.15	0.19	0.24	0.36	0.49	0.64	0.81
	2	0.625	1	0.17	18.6	19.8	20.9	21.7	22.5	23.1	25.1	—
			2	0.63	22.5	24.3	25.9	27.3	28.5	29.6	33.0	—
			4	2.39	25.1	27.5	29.6	31.5	33.1	34.6	39.4	—
			6	5.22	26.2	28.8	31.1	33.2	35.1	36.7	42.2	—
			Airside Ps		0.23	0.32	0.41	0.51	0.62	0.74	1.31	—
	3	0.625	1	0.08	21.8	23.1	24.1	25.0	26.3	27.3	—	—
			2	0.31	27.5	29.8	31.6	33.2	35.8	37.8	—	—
			4	1.21	31.7	34.8	37.5	39.9	43.8	47.0	—	—
			8	4.78	34.3	38.1	41.5	44.4	49.5	53.8	—	—
			Airside Ps		0.35	0.47	0.61	0.77	1.11	1.51	—	—
	4	0.875	2	0.21	30.9	33.4	35.4	37.1	39.9	—	—	—
			4	0.84	36.3	40.0	43.1	45.9	50.5	—	—	—
			6	1.87	38.5	42.8	46.5	49.8	55.4	—	—	—
			8	3.32	39.8	44.4	48.5	52.1	58.3	—	—	—
			Airside Ps		0.46	0.63	0.82	1.02	1.49	—	—	—

- 1) All coil performance in accordance with AHRI Standard 410-2001
- 2) Heating capacities are in MBH
- 3) Performance data based on a temperature differential of 115°F (180°F entering water temperature and 65°F entering air temperature)
- 4) For temperature differentials other than 115°F, multiply the MBH by the correction factors below
- 5) Head Loss is in feet of water
- 6) Airside ΔPs is the air pressure drop of the hot water coil
- 7) Aire temperature rise = 927 x MBH/CFM
- 8) Water temperature drop = 2.04 x MBH/GPM
- 9) Values in tables are listed for 0 ft. of altitude and no glycol in the system

**MBH CORRECTION FACTORS**

ΔT	50	60	70	80	90	100	115	125	140	150
Factor	0.44	0.52	0.61	0.70	0.79	0.88	1.00	1.07	1.20	1.30

### XG-TL-500 HOT WATER COILS MBH SELECTION DATA – IMPERIAL UNITS

Unit Size	Rows	Connection OD (in)	GPM	Head Loss (ft-H <sub>2</sub> O)	CFM							
					500	600	700	800	1000	1200	1400	1600
9 10	1	0.625	1	0.11	13.4	14.3	15.0	15.6	16.7	17.5	18.2	18.7
			2	0.43	15.7	16.9	17.9	18.8	20.4	21.6	22.7	23.6
			4	1.63	17.2	18.6	19.9	21.1	23.0	24.7	26.0	27.3
			6	3.58	17.8	19.3	20.7	22.0	24.1	25.9	27.5	28.8
			Airside Ps		0.06	0.08	0.10	0.13	0.19	0.25	0.33	0.42
	2	0.875	1	0.36	20.5	21.9	23.0	24.0	25.5	26.7	27.7	28.5
			2	1.43	25.2	27.4	29.3	30.9	33.6	35.8	37.6	39.1
			3	3.20	27.3	29.9	32.2	34.2	37.6	40.4	42.8	44.8
			4	5.68	28.5	31.4	34.0	36.2	40.0	43.2	46.0	48.3
			Airside Ps		0.12	0.17	0.22	0.27	0.39	0.54	0.69	0.87
	3	0.875	1	0.24	23.7	25.1	26.2	27.1	28.6	29.6	30.4	31.1
			2	0.94	30.4	33.0	35.1	36.9	39.9	42.2	44.0	45.5
			4	3.79	35.3	39.0	42.2	45.0	49.8	53.6	56.8	59.6
			6	8.53	37.3	41.6	45.3	48.6	54.3	59.0	63.0	66.5
			Airside Ps		0.19	0.25	0.33	0.41	0.59	0.80	1.04	1.30
	4	0.875	2	0.83	34.3	37.3	39.7	41.7	45.0	47.5	49.5	—
			4	3.35	40.3	44.7	48.6	51.9	57.5	62.0	65.8	—
			6	7.54	42.7	47.9	52.4	56.5	63.4	69.1	73.9	—
			8	13.41	44.0	49.6	54.6	59.0	66.8	73.2	78.8	—
			Airside Ps		0.25	0.34	0.43	0.54	0.79	1.07	1.39	—

Unit Size	Rows	Connection OD (in)	GPM	Head Loss (ft-H <sub>2</sub> O)	CFM							
					600	800	1000	1200	1400	1600	1800	2000
12-0V	1	0.5	0.5	0.27	13.8	14.9	15.7	16.3	16.9	17.3	17.6	17.9
			1	1.04	17.5	19.4	20.8	22.0	23.0	23.8	24.5	25.2
			2	3.93	20.1	22.7	24.8	26.5	28.0	29.3	30.4	31.4
			3	8.57	21.2	24.1	26.5	28.5	30.2	31.7	33.0	34.2
			Airside Ps		0.05	0.08	0.12	0.16	0.21	0.27	0.33	0.40
	2	0.875	1	0.27	25.4	28.1	30.1	31.7	32.9	34.0	34.8	35.6
			2	1.02	31.3	35.8	39.3	42.1	44.5	46.5	48.2	49.7
			4	3.85	35.4	41.3	46.1	50.2	53.7	56.7	59.4	61.8
			6	8.40	37.1	43.6	49.0	53.6	57.7	61.2	64.4	67.2
			Airside Ps		0.11	0.18	0.26	0.35	0.46	0.57	0.69	0.83
	3	0.875	2	0.39	38.5	43.7	44.7	50.8	53.4	55.5	57.2	58.8
			4	1.52	44.3	52.0	58.1	63.2	67.5	71.2	74.4	77.3
			6	3.37	46.6	55.3	62.6	68.6	73.9	78.5	82.5	86.2
			8	5.94	47.8	57.2	65.0	71.7	77.5	82.7	87.2	91.4
			Airside Ps		0.17	0.27	0.39	0.53	0.68	0.85	1.04	1.24
	4	0.875	3	0.55	47.4	55.2	61.1	65.9	69.9	73.2	76.0	—
			5	1.51	51.7	61.6	69.6	76.2	81.9	86.7	91.0	—
			7	2.94	53.7	64.7	73.8	81.5	88.2	94.0	99.2	—
			10	5.95	55.3	67.2	77.3	86.0	93.6	100.3	106.4	—
			Airside Ps		0.22	0.36	0.52	0.70	0.91	1.14	1.39	—

- 1) All coil performance in accordance with AHRI Standard 410-2001
- 2) Heating capacities are in MBH
- 3) Performance data based on a temperature differential of 115°F (180°F entering water temperature and 65°F entering air temperature)
- 4) For temperature differentials other than 115°F, multiply the MBH by the correction factors below
- 5) Head Loss is in feet of water
- 6) Airside ΔPs is the air pressure drop of the hot water coil
- 7) Air temperature rise = 927 x MBH/CFM
- 8) Water temperature drop = 2.04 x MBH/GPM
- 9) Values in tables are listed for 0 ft. of altitude and no glycol in the system

#### MBH CORRECTION FACTORS

ΔT	50	60	70	80	90	100	115	125	140	150
Factor	0.44	0.52	0.61	0.70	0.79	0.88	1.00	1.07	1.20	1.30

**XG-TL-500 HOT WATER COILS MBH SELECTION DATA – IMPERIAL UNITS**

Unit Size	Rows	Connection OD (in)	GPM	Head Loss (ft-H <sub>2</sub> O)	CFM							
					600	700	800	1000	1500	2000	2500	3000
14-OV	1	0.625	0.5	0.33	15.4	16.1	16.6	17.6	19.1	20.0	20.6	21.1
			1	1.23	19.7	20.9	21.9	23.7	26.7	28.8	30.3	31.4
			2	4.65	22.8	24.5	26.0	28.5	33.1	36.4	39.0	41.1
			3	10.15	24.1	26.0	27.6	30.5	35.9	39.9	43.1	45.6
			Airside Ps		0.03	0.04	0.05	0.07	0.15	0.24	0.36	0.49
	2	0.875	1	0.32	27.8	29.5	30.9	33.2	37.0	39.3	40.9	42.1
			2	1.22	34.5	37.2	39.7	43.7	51.1	56.0	59.7	62.5
			4	4.62	39.0	42.7	45.9	51.6	62.5	70.4	76.5	81.5
			6	10.09	40.8	44.8	48.5	54.9	67.4	76.8	84.3	90.4
			Airside Ps		0.07	0.09	0.11	0.16	0.32	0.51	0.74	1.01
	3	0.875	2	0.43	42.4	45.7	48.6	53.3	61.2	66.2	69.7	72.3
			4	1.68	48.5	53.3	57.5	64.8	78.4	87.9	95.0	100.6
			6	3.72	50.8	56.2	61.0	69.6	86.1	98.1	107.4	114.9
			8	6.55	52.0	57.7	62.9	72.2	90.4	104.0	114.8	123.6
			Airside Ps		0.10	0.13	0.17	0.24	0.47	0.77	1.11	1.51
	4	0.875	2	0.26	46.8	50.6	53.7	58.7	67.0	72.0	75.4	—
			6	2.30	57.0	63.4	69.2	79.4	98.9	113.0	123.7	—
			8	4.06	58.4	65.2	71.5	82.7	104.6	121.0	133.7	—
			10	6.32	59.3	66.4	73.0	84.8	108.3	126.3	140.5	—
			Airside Ps		0.14	0.18	0.22	0.32	0.63	1.02	1.49	—

Unit Size	Rows	Connection OD (in)	GPM	Head Loss (ft-H <sub>2</sub> O)	CFM							
					600	700	800	1000	1500	2000	2500	3000
16-OV	1	0.625	0.5	0.36	16.2	16.9	17.6	18.5	20.1	21.0	21.7	22.2
			1	1.37	20.9	22.2	23.4	25.2	28.5	30.7	32.3	33.6
			2	5.19	24.4	26.2	27.8	30.5	35.6	39.3	42.1	44.4
			3	11.33	25.7	27.8	29.6	32.7	38.8	43.2	46.7	49.5
			Airside Ps		0.02	0.03	0.04	0.06	0.11	0.19	0.27	0.37
	2	0.875	2	1.36	36.1	39.1	41.7	46.1	54.0	59.3	63.3	66.3
			3	2.96	39.2	42.7	45.9	51.4	61.7	69.0	74.6	79.0
			4	5.15	40.9	44.8	48.4	54.5	66.4	75.0	81.8	87.2
			5	7.92	42.0	46.2	49.9	56.6	69.5	79.1	86.7	92.9
			Airside Ps		0.05	0.07	0.09	0.12	0.24	0.39	0.57	0.78
	3	0.875	2	0.46	44.4	48.0	51.1	56.2	64.8	70.2	73.9	76.7
			4	1.79	50.7	55.8	60.4	68.4	83.2	93.6	101.4	107.5
			6	3.95	53.0	58.7	64.0	73.3	91.3	104.6	114.9	123.2
			8	6.95	54.1	60.3	65.9	76.0	95.9	110.9	122.9	132.7
			Airside Ps		0.08	0.10	0.13	0.19	0.37	0.59	0.86	1.17
	4	0.875	2	0.27	49.0	53.0	56.4	61.8	70.7	76.1	79.7	82.3
			4	1.07	56.4	62.4	67.8	77.0	94.0	105.6	114.1	120.6
			8	4.22	60.4	67.7	74.4	86.5	110.5	128.5	142.6	154.1
			10	6.56	61.2	68.8	75.8	88.6	114.3	134.0	149.8	162.7
			Airside Ps		0.11	0.14	0.17	0.25	0.49	0.79	1.15	1.56

- 1) All coil performance in accordance with AHRI Standard 410-2001
- 2) Heating capacities are in MBH
- 3) Performance data based on a temperature differential of 115°F (180°F entering water temperature and 65°F entering air temperature)
- 4) For temperature differentials other than 115°F, multiply the MBH by the correction factors below
- 5) Head Loss is in feet of water
- 6) Airside ΔPs is the air pressure drop of the hot water coil
- 7) Air temperature rise = 927 x MBH/CFM
- 8) Water temperature drop = 2.04 x MBH/GPM
- 9) Values in tables are listed for 0 ft. of altitude and no glycol in the system

**MBH CORRECTION FACTORS**

ΔT	50	60	70	80	90	100	115	125	140	150
Factor	0.44	0.52	0.61	0.70	0.79	0.88	1.00	1.07	1.20	1.30

## XG-TL-500 HOT WATER COILS

When ordered with the air terminal, the hot water coil is shipped attached to the discharge of the terminal casing via slip and drive connections. The discharge end of the casing has slip and drive connections for easy connection to downstream ductwork. The hot water coil is constructed of aluminum fin and copper serpentine-type tubes with male sweat connections tested at 300 psig.

Coil selection may be made using Greenheck Terminal Selection Software. Contact your Greenheck representative for a copy. In the interest of energy conservation and due to the possibility of condensation, all hot water coils are marked, "Coil must be externally insulated after installation in the field." Hot water coils are tested in accordance to AHRI Standard 410.

### HOT WATER COIL CONSTRUCTION DETAILS

- Hot water coils are factory mounted on the discharge of the terminal and are available with an optional integral coil access door.
- Coils are enclosed in 20 gauge coated steel casing with slip and drive connection.
- Fins are rippled and sine wave type constructed from heavy gauge aluminum, mechanically bonded to the tubes.
- Tubes are copper with a minimum wall thickness of 0.016" with male sweat header connections.
- Coils are leak tested to 300 psig with minimum burst of 2000 psig at ambient temperature.
- Coil performance data is based on tests run in accordance with AHRI Standard 410; coils are AHRI certified and include AHRI label.

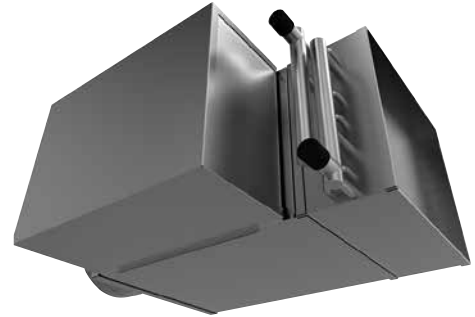

## XG-TL-500 COIL CONNECTION SIZE

Outside Diameter (OD) connection size, Inches				
Inlet Size	1 Row	2 Row	3 Row	4 Row
4	5/8"	7/8"	7/8"	7/8"
5	5/8"	7/8"	7/8"	7/8"
6	5/8"	7/8"	7/8"	7/8"
7	5/8"	7/8"	7/8"	7/8"
8	5/8"	7/8"	7/8"	7/8"
9	5/8"	7/8"	7/8"	7/8"
10	5/8"	7/8"	7/8"	7/8"
12-0V	5/8"	7/8"	7/8"	7/8"
14-0V	5/8"	7/8"	7/8"	7/8"
16-0V	5/8"	7/8"	7/8"	7/8"

*All coils have 10 fins/inch*

All accessories that can be attached to the Single Duct Boxes are not a part of the AHRI certification program but ratings can be affected by their use.



## XG-TL-500 ELECTRIC HEAT

Greenheck's electric heaters are factory mounted, ETL listed to meet electrical safety standards and comply with UL 1995 and CSA 236. Electric heaters, as pictured on this page, are integral to the air terminal unit. The discharge end has slip and drive connections for easy connection to downstream ductwork. The heater plenums are an integral attenuator that is lined with the same liner selected for the casing. The integral attenuator also helps to reduce discharge sound.

Single duct electric heaters are a side-mounted, slide in style to allow easy field maintenance. The heating elements are designed to minimize hot spots and nuisance tripping of the thermal cutouts.

### INCLUDED WITH EACH HEATER ASSEMBLY:

- Heater and cabinet mounted on the discharge of the XG-TL-500
- Discharge plenum comes standard with ½" dual density fiberglass lining, optional liners are available
- Air pressure switch
- De-energizing magnetic contactors per step and backup magnetic contactor
- Magnetic contactors are the standard configuration, optional SCR control is available
- Backup manual reset high temperature limit (disc type)
- Non-isolated transformer
- Slip and drive connections
- Heater is shipped factory mounted and wired

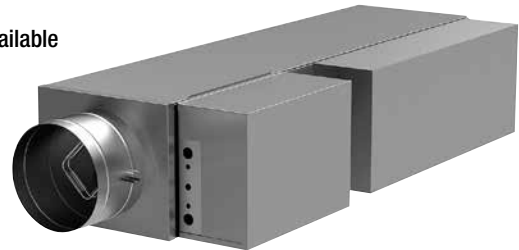

### ELECTRIC HEATER ASSEMBLY CONSTRUCTION DETAILS

- Electric reheat coils are factory mounted on the discharge of the air terminal. The heaters are ETL listed for zero clearance, and are tested in accordance with UL Standard 1995, CSA-C22.2 No. 236 and the National Electric Code (NEC). Heater casings are constructed of galvanized steel. Element wire is high grade nichrome alloy derated to 45 watts per square inch density. Element wire is supported by moisture-resistant steatite ceramics.
- Ceramics are enclosed in reinforcement brackets spaced across the heater element rack at 2" to 4" intervals. Controls are contained in a NEMA 1 control cabinet with a hinged, latching door. A permanent wiring diagram is affixed to the inside of the control cabinet door for field reference.

All accessories that can be attached to the Single Duct Boxes are not a part of the AHRI certification program but ratings can be affected by their use.

**XG-TL-500 ELECTRIC HEATER CAPACITIES**

Single Phase XG-TL-500 kW Limits				
Unit Size	Heater Voltage	Min. kW per Step	Max. kW	Max. Steps
4 5 6	120	1	4	2
	208	0.5	4	2
	240	0.5	4	2
	277	0.5	4	2
	480	1.5	4	2
7 8	120	1	5	3
	208	0.5	8	3
	240	0.5	8	3
	277	0.5	8	3
	480	1	8	3
9 10	120	0.5	5	3
	208	0.5	9.5	3
	240	0.5	11	3
	277	0.5	12	3
	480	1	23	3
12-0V	120	0.5	5	3
	208	0.5	9.5	3
	240	0.5	11	3
	277	0.5	12	3
	480	0.5	23	3
14-0V	120	0.5	5	3
	208	0.5	9.5	3
	240	0.5	11	3
	277	0.5	12	3
	480	0.5	23	3
16-0V	120	0.5	5	3
	208	0.5	9.5	3
	240	0.5	11	3
	277	0.5	12	3
	480	0.5	23	3

Three Phase XG-TL-500 kW Limits				
Inlet Size	Heater Voltage	Min. kW per Step	Max. kW	Max. Steps
4 5 6	208	0.5	4	2
	480	1.5	4	2
7 8	208	1.5	8	3
	480	1.5	8	3
9 10	208	1.5	13	3
	480	1.5	15	3
12-0V	208	1.5	16	3
	480	1.5	23	3
14-0V	208	1.5	16	3
	480	1.5	24	3
16-0V	208	1.5	16	3
	480	1.5	39	3

**NOTES:**

1. Heaters less than 10 kW are specifiable to nearest 0.5 kW. Heaters greater than 10 kW are specifiable to nearest 1 kW.
2. Minimum flow rate for electric heat is 70 CFM / kW. Lower CFM's can cause nuisance tripping, excessive discharge temperatures, rapid cycling, and rapid element failure. Electric Heat units running below 70 CFM / kW will void all warranties.
3. For optimum thermal comfort, the suggested discharge temperature should not exceed 20°F above room set point.
4. We do not recommend discharge temperatures in excess of 115°F to protect heater coils.
5. Maximum number of steps at "Min. kW per Step" is one step.
6. If more than 1 heater is wired into a building's circuit breaker (multi-outlet branch circuit) each heater will require the addition of power side fusing.

**ELECTRIC HEAT SELECTION:**

A. Specify electric duct heaters using voltage, phase, kW, and number of steps.

B. Use above chart to select voltage. Calculate required kW using following equations:

$$kW = \frac{BTU / HR}{3413} \qquad kW = \frac{CFM \times \Delta \times 1.085}{3413} \qquad \Delta = \frac{kW \times 3413}{CFM \times 1.085}$$

$$CFM = \frac{kW \times 3413}{\Delta \times 1.085} \qquad CFM = \frac{kW \times 3413}{\Delta \times 1.085}$$

\* air density at sea level — reduce by 0.036 for each 1000 feet of altitude above sea level

Where: BTU / Hr = Required heating capacity

CFM = volume of air during heating. Typically 100% of maximum cooling air volume

Δ = desired air temperature rise across the electric heater

Inlet air temperature = primary air temperature, usually 55°F

### XG-TL SOUND ATTENUATORS

- The optional acoustically lined sound attenuator is designed to further reduce discharge sound levels from the air terminal. The chart below gives reductions to the discharge sound power figures at minimum static pressure for each octave band.
- Attenuators are integral to the box
- Standard attenuator is 3 ft. (36 inches) long

XG-TL-500						
Octave Band / Frequency (Hz)						
Unit Size	2 / 125	3 / 250	4 / 500	5 / 1000	6 / 2000	7 / 4000
4	2	4	8	18	20	13
5	2	4	8	18	20	13
6	2	4	8	18	20	13
7	2	3	8	16	16	11
8	2	3	8	16	16	11
9	1	3	7	15	15	11
10	1	3	7	15	15	11
12-OV	2	4	8	17	17	12
14-OV	2	3	8	16	16	11
16-OV	1	3	7	15	15	10

All accessories that can be attached to the Single Duct Boxes are not a part of the AHRI certification program but ratings can be affected by their use.

### XG-TL-500 RECOMMENDED MIN/MAX AIRFLOW RANGES

XG-TL-500 Recommended Minimum and Maximum Airflow Ranges						
Unit Size	Pneumatic / Analog		Digital Controls - DDC			
			Transducer Min ΔP / Min CFM		Transducer Max ΔP / Max CFM	
	Min CFM	Max CFM	0.01	0.03	1	1.5
4	50	300	30	50	300	370
5	65	375	40	65	375	460
6	95	540	55	95	540	660
7	130	760	75	130	760	930
8	170	990	100	170	990	1210
9	220	1250	125	220	1250	1530
10	285	1640	165	285	1640	2010
12-OV	395	2270	225	395	2270	2780
14-OV	495	2850	285	495	2850	3490
16-OV	615	3550	355	615	3550	4350

### PERFORMANCE NOTES

- 1) Actual minimum and maximum airflow ranges depend on the transducer differential pressure range and accuracy.
- 2) Contact the manufacturer of installed DDC equipment for transducer minimum and maximum differential pressure, ΔP, limits.
- 3) Minimum CFM for Pneumatic and Analog controls are based on a sensor differential pressure of 0.03 in. w.g.
- 4) Maximum CFM for Pneumatic and Analog controls are based on a sensor differential pressure of 1.00 in. w.g.
- 5)  $CFM = (\sqrt{\Delta P}) * K$  Factor
- 6) K Factor is the airflow at 1" ΔP
- 7) Recommendations are for pressure independent units.
- 8) Pressure dependent units minimum CFM is always zero and there is no maximum.

## XG-TL-500 CONTROL SEQUENCE OFFERINGS



### PPD-PNEUMATIC PRESSURE DEPENDENT

- Direct Acting / Normally Closed (DA / NC)
- Reverse Acting / Normally Open (RA / NO)



### PPI-PNEUMATIC PRESSURE INDEPENDENT

- Direct Acting / Normally Closed (DA / NC)
- Direct Acting / Normally Open (DA / NO)
- Reverse Acting / Normally Closed (RA / NC)
- Reverse Acting / Normally Open (RA / NO)
- Static Pressure Control



### EPD-ELECTRIC PRESSURE DEPENDENT

- Cooling Only
- Cooling with Reheat
- Static Control
- Actuator Only



### API-ANALOG PRESSURE INDEPENDENT

- Cooling Only
- Cooling with Heat
- Night Setback / Morning Warm-up
- Heating / Cooling Changeover
- Static Pressure Control



### DDC-DIRECT DIGITAL CONTROL

BACnet

- Cooling Only
- Cooling or Heating
- Hot Water Reheat
- Electric Reheat