

Installation, Operation and Maintenance Manual

Please read and save these instructions for future reference. Read carefully before attempting to assemble, install, operate or maintain the product described. Protect yourself and others by observing all safety information. Failure to comply with these instructions will result in voiding of the product warranty and may result in personal injury and/or property damage.



XG-XG-Fan Powered Air Terminals

Receiving Inspection

Prior to removing the shipping materials, visually inspect the packing materials. There should be a black plastic strip wrapped in the clear plastic stretch wrap. If this black plastic strip is missing, the shipment may have been repacked by the shipper and you should make a note of this on the shipping documents and inform the delivering carrier.

After unpacking the XG-Fan Powered Air Terminals, check for shipping damage. If any shipping damage is found, report it immediately to the delivering carrier.

Always store the product in a clean dry location prior to installation.

Units with controls are not recommended for use in ambient temperatures greater than 95° F. For protection of controls, do not store in temperatures above 135°F.

 **Caution:** Do not use the flow sensor, connecting tubing or damper shaft as a lift point. Damage to the components may result.

Hanging/Installation Requirements

- ☑ The XG-Fan Powered Air Terminal should be suspended from the building structure in a horizontal plane with the bottom access panel facing down.
- ☑ Do not obstruct the bottom access panels or side mounted control enclosure cover.
- ☑ Use the required mounting method prescribed for rectangular duct per the job specification.
- ☑ An alternate method involves using hanging straps located at both ends of the Fan Power Air Terminal correctly sized to support the unit weight. (See figure 1)
- ☑ XG-Fan Powered Air Terminals may also be suspended with factory supplied and field installed hanger brackets and field supplied and installed hanger rods. (See figure 2)
- ☑ **Trapeze hangers are not recommended as they can block the bottom access panels for the motor and blower.**

Note:

XG-Fan Powered Air Terminals are not designed nor suitable for outdoor use.

In advance of startup, verify all electrical connections are tight and that the correct voltage is supplied to the XG-Fan Powered Air Terminal per the voltage listed on the label. If factory supplied controls are present, review all wiring diagrams for complete working knowledge.

Figure 1 Hanging Straps

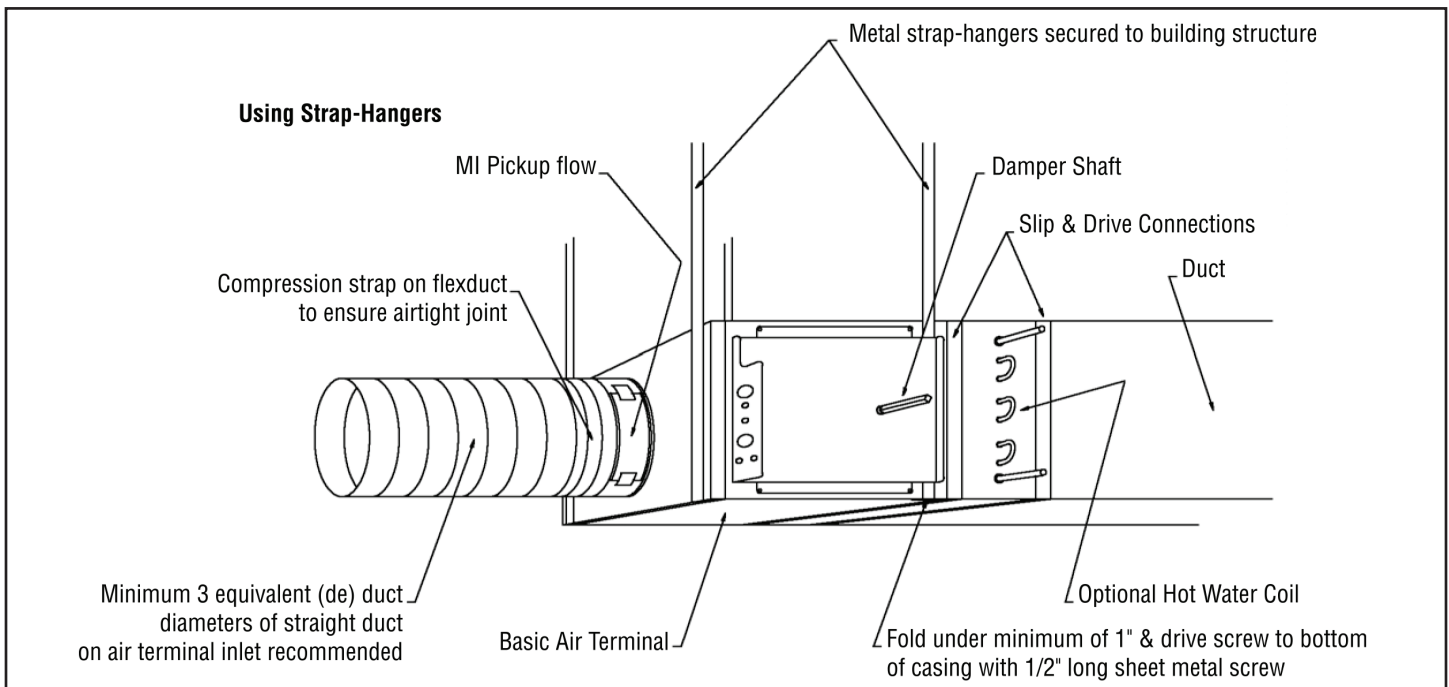
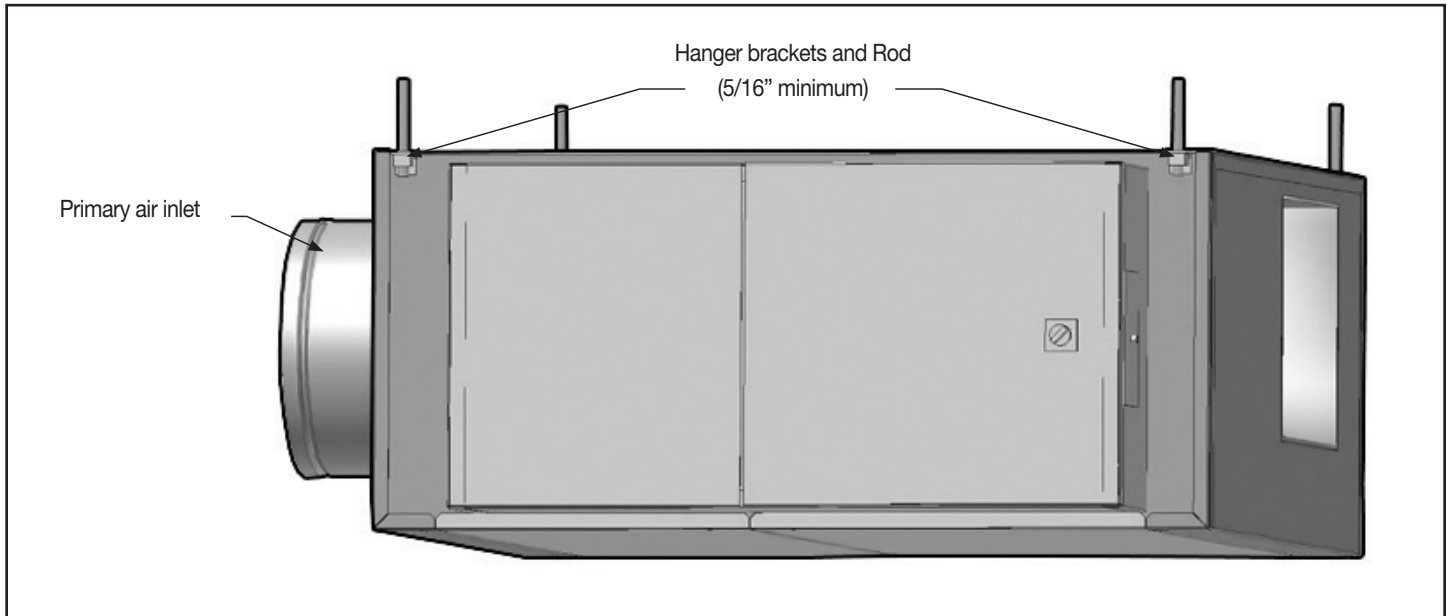

Figure 2 Optional Hanger Brackets and Hanger Rods



Important

If equipped with pneumatic controls, the orientation of the XG-Fan Powered Air Terminal unit is critical. The pneumatic controls must be mounted right side up. The XG-Fan Powered Air Terminal must be level within + or - 10 degrees of horizontal, both parallel to the air flow and at right angle of air flow. The control side of the XG-Fan Powered Air Terminal is labeled with an arrow indicating up. Unless otherwise noted, most electric, analog electronic and digital are not position sensitive and may be installed in any orientation.

Minimum Clearance for Access

XG-Fan Powered Air Terminals require sufficient space to allow servicing of the controls, motor/blower and electric reheat (if applicable) and single point power hook up. A minimum of 3" of vertical clearance is required below the bottom of the unit. Horizontal clearance requirements are dependent upon access panel dimensions which are indicated on the appropriate submittal. For control panel access, a minimum of 18" is recommended. See the appropriate submittal for control panel location.

Note: These clearances recommendations are not meant to preclude NEC requirements or local building codes that may be applicable, which are the responsibility of the installing contractor.

Connecting Duct Work

1. Slip each inlet duct over the inlet collar of the XG-Fan Powered Air Terminal.
2. Fasten and seal the connection by method prescribed by job specification.
3. The diameter of the inlet duct in inches, must be equal to the listed size of the Fan Powered Air Terminal; e.g. a duct that actually measures 8 inches must be fitted to a size 8 inch XG-Fan Powered Air Terminal. The inlet tube of the XG-Fan Powered Air Terminal is manufactured 1/8" smaller than the listed size in order to fit inside the duct.

Note: Do not insert duct work inside the inlet collar of the XG-Fan Powered Air Terminal. Inlet duct should be installed in accordance with SMACNA guidelines.

4. If an inlet air flow sensor is installed, it is recommended the installer provide a minimum of 3 duct diameters of straight duct at the XG-Fan Powered Air Terminal inlet.
5. The outlet end of the XG-Fan Powered Air Terminal is designed for use with connections flanged outlets. (*Slip and drive duct connections optional.*)
6. A rectangular duct the size of the Air Terminal outlet should be attached. (*Refer to submittal for correct size.*)

Field Electrical Wiring

- ☑ All field wiring must comply with local building codes and NEC. (ANSI/NFPA 70-2002)
- ☑ When Applicable, electrical control and piping diagrams are attached to the inside of the control enclosure cover of the XG-Fan Powered Air Terminal.
- ☑ Use copper only conductors.
- ☑ The XG-Fan Powered Air Terminal must be properly grounded per NEC 424-14 and 250.
- ☑ Always check product label for voltage and current data to determine the proper wire size and over current protection.
- ☑ The control cabinet contains live electrical parts.
- ☑ Contacting these parts with power applied may cause serious injury or even death.
- ☑ The control panel cover must be closed or in place before applying electric power to the XG-Fan Powered Air Terminal.
- ☑ These recommendations are not meant to preclude NEC requirements or applicable local building codes and are the sole responsibility of the installing contractor.

XG-Fan Powered Air Terminals with Electric Reheat

- Always inspect the electric heating coils for damage prior to installing the XG-Fan Powered Air Terminal.
- All electric reheat is balanced by kW per stage.
- The installing electrician should rotate these electric reheat stages by phase in order to balance the buildings electrical load.
- The “UP” arrow orientation must be followed to prevent nuisance tripping or over heating which will cause damage to the electric heater and or building.
- Motor fusing is provided on all XG-Fan Powered Air Terminals.



Caution: XG-Fan Powered Air Terminals must not be operated without downstream duct work in place. Failure to have downstream ductwork installed will expose the line voltages and high temperature present in the operating heater elements. Contact with these heater elements may cause serious injury or death.

XG-Fan Powered Air Terminals with Hot Water Coils

- Always inspect the hot water coils for damage prior to installing the XG-Fan Powered Air Terminal.



Caution: The copper tubing should not be used as lift points.

- The hot water coil casing must be field insulated.
- The hot water coils do not have drip pans and are not suitable for use as cooling coils.

Controls

For information on controls provided by other manufactures and installed on the Air Terminals, contact the local branch or dealer.

Important

XG-Fan Powered Air Terminals with digital controls, if factory programmed, incorporate specific communication addresses. Installing the XG-Fan Powered Air Terminal in a different location than noted on the XG-Fan Powered Air Terminal label and building plans, may result in excessive start up labor and is the sole responsibility of the contractor.

Inlet Flow Sensor

XG-Fan Powered Air Terminals are shipped with factory installed (where applicable) pressure differential inlet flow sensors in the primary inlet. See figure 3 for calibration curve and K factors. Model BP600 Air Terminals offer an optional downstream flow sensor for field installation a minimum of 3 feet downstream of box discharge.

Labeling

XG-Fan Powered Air Terminals are shipped from the factory with multiple information labels.

Control Sequence Label: Affixed to the inside of the control enclosure cover. Displays piping/wiring diagram, control sequence number and any optional components.

Terminal I.D. Label: Affixed to the outside of the control enclosure cover. Shows tagging, representative name, sales order number, applicable certifications, model number, Made in USA, any applicable electrical data and UL compliance markings.

AHRI Certification Label: Identifies applicable industry test standard and certifies XG-Fan Powered Air Terminal is in compliance.

AHRI Certification on Hot Water Coil (if applicable): Identifies applicable industry test standard and certifies hot water coil compliance.

Orientation Label: Identifies the proper air flow direction and top of XG-Fan Powered Air Terminal.

Troubleshooting

Investigating Noise Complaints

- ☑ Noise from a XG-Fan Powered Air Terminal can be due to a variety of conditions and can be difficult to eliminate.
- ☑ The first step is to isolate the type, source and direction.
- ☑ Generally, noise heard at the air outlet is considered a discharge type.
- ☑ Noise heard through the ceiling is considered radiated noise.
- ☑ For detailed information concerning noise transmission in buildings, refer to AHRI Standard 885-2008, "Procedure for estimating occupied space sound levels in the application of Air Terminals and air outlets".

Discharge Noise

- ☑ This is usually caused by high static or little to no internal duct lining downstream of the Air Terminal.
- ☑ It can sometimes be caused by air outlet itself.
- ☑ Air outlet generated sounds can be reduced by reducing flow or increasing an outlet size.
- ☑ Reducing static pressure, flow or adding additional downstream attenuation materials will reduce discharge sounds from the Air Terminal.

Radiated Noise

- ☑ Radiated noise is most commonly associated with XG-Fan Powered Terminals.
- ☑ The suspension and the ducting of these XG-Fan Powered Air Terminals is crucial to minimize any vibrations from being transmitted through structure or ductwork.
- ☑ Severe vibrations or any sounds of knocking or rubbing should be immediately investigated and the XG-Fan Powered Air Terminal shut down.
- ☑ Occasionally, shipping, handling or installing can unbalance a blower.

Initial Startup/Adjustment of Fan Flow Rate

1. Check the discharge ductwork is connected.
2. Verify all the electrical connections are properly installed and that all safety covers and access panels are in place.
3. Inspect the XG-Fan Powered Air Terminal and duct work for the presence of any packaging or foreign materials and remove if found.
4. Fan motor is shipped from the factory set at full speed.
5. Allow the motor to warm up for a period of 10 minutes prior to adjusting the SCR motor speed control.
6. During the warm up period, inspect the ductwork for leaks and make necessary repairs.



Caution: Do not operate the XG-Fan Powered Air Terminal if the downstream ductwork is not present.

7. Flow adjustment: Turn the SCR motor speed control counter-clockwise to reduce the fan speed.

8. Turn the SCR motor speed control clockwise to increase fan speed.
9. Set the XG-Fan Powered Air Terminal to full heating (maximum induction).
10. Adjust the downstream dampers (if present).
11. Adjust the SCR motor speed control to deliver the desired air flow rate by measuring the air delivered to the room outlets using a flow hood or other instruments.
12. Set the XG-Fan Powered Air Terminal to full cooling (maximum primary air).
13. The fan speed may need to be readjusted with the primary air and ventilation at maximum set point to ensure that no supply air is discharged at the plenum air intake port.
14. Recheck full heating.



Warning: SCR motor speed control will cause all electric motors to run hotter. Speed reduction should never fall below 700 RPM for proper lubrication of the bearings/sleeves.

Fan Motor Maintenance

The fan motor is equipped with permanently lubricated bearings. Inspect the fan motor, fan and XG-Fan Powered Air Terminal unit for a buildup of dust or foreign material. Clean as required based on the operating environment and type of insulation installed.

Fan Startup for Series Constant Volume XG-Fan Powered Air Terminals

- It is standard operating procedure for Series (Constant Volume) XG-Fan Powered Air Terminal units to close primary air damper if the fan is shut off during unoccupied times.
- Upon morning warm up, the primary air damper should be closed before the fan is re-energized or restarted to prevent the fan blower wheel from running backwards.
- Once the fan is running in the proper direction, the primary damper can be re-opened.
- The reason for this coordination between the primary damper and fan is due to the Series Constant Volume fan design.
- The fan blower and motor are positioned "in series" with the primary inlet and any residual primary air traveling through the XG-Fan Powered Air Terminal can cause the fan blower wheel to run backwards.
- If the fan blower wheel is rotating backwards at fan startup and the fan motor is re-energized, this condition results in a high torque condition which could lead to premature motor failure.
- It can also loosen the set screw on the fan blower wheel-to-motor shaft.
- This condition is not a manufacturing defect and thus not covered under our standard warranty.
- If the control scheme is as described above, the fan blower wheel set screw should be periodically checked for tightness and verify that LOCKTITE is applied.

Troubleshooting

If the fan motor does not energize:

- ☑ With the power off, verify for free rotation of fan blower wheel using standard safety precautions.
- ☑ Check for proper supply voltage.
- ☑ Disconnect switch (if supplied), should be in the ON position.
- ☑ Check fan motor fusing (always use time delay fusing).
- ☑ Check for proper control signal, 24 VAC at fan.
- ☑ Verify contractor and fan relay energized.
- ☑ If Parallel Variable Fan Air Terminal, verify there is a call for fan.

Excessive Noise When Fan Motor Runs

- ☑ Check for clearance problems with fan motor and blower components.
- ☑ Check that all components are properly assembled.
- ☑ Verify the ductwork does not have any leaks or loose connections and diffusers are not rattling or balancing dampers are not generating noise.
- ☑ Verify maximum CFM is not too high or discharge static pressure too low.

Insufficient Air Flow

- ☑ Check for restrictions in ductwork.
- ☑ Check for dirty or clogged hot water coils (if supplied).
- ☑ Verify intake filter is not clogged or dirty (if supplied).
- ☑ Re-adjust SCR motor speed control.
- ☑ Verify discharge static is not too high.

Note: If repair or replacement of fan blower or motor is required, the fan motor and blower should be removed as an assembly.

Fan Motor/Blower Removal

1. Disconnect power to XG-Fan Powered Air Terminal.
2. Remove bottom fan motor/blower access panel.
3. Disconnect motor wires for fan motor.
4. Remove the two bottom screws holding motor/blower assembly to XG-Fan Powered Air Terminal discharge end plate bracket.
5. Loosen the top two screws holding motor/blower assembly to XG-Fan Powered Air Terminal discharge end plate bracket.
6. Lift the fan motor/blower assembly upward to disengage the top two motor screws.
7. Do not allow the fan motor/blower assembly to hang from the power leads.

Fan Motor Removal from Blower

1. Loosen the blower wheel hub set screw to fan motor shaft.
2. Remove the 3 screws holding motor leg brackets to blower housing.
3. Slide the fan motor out of the fan blower wheel.
4. Reverse steps 1-3 to re-install motor to blower wheel.
5. Verify isolation grommets are in place on the fan motor legs.
6. Verify the blower wheel set screw is properly torqued and LOCKTITE has been applied to threads.
7. Do not over tighten the fan motor leg mounting screws.

Electric Duct Heater



Caution: Use extreme care if testing the electric heater with power on!

The control cabinet contains live electrical parts. Contacting these parts with the power applied may cause serious injury or death.



Caution: This unit should be serviced by a licensed electrician or a similarly qualified electrical service technician!

If the electric heater does not operate:

- ☑ Check electric power into the unit and verify the input power agrees with the label data.
- ☑ Verify the Air Terminal is installed properly (according to the air flow orientation).
- ☑ Review the wiring diagram attached to the inside of the control enclosure cover to verify the field wiring is correct with proper gauge wire, overcurrent protection and properly grounded.

If the electric heater cycles on and off:

- ☑ Verify the air flow is uniformly distributed across the face of the heater elements.
- ☑ Check for obstructions in the duct or insufficient air flow. (70 CFM per kW required)

If conditioned space fails to warm up:

- ☑ Verify the electric heater controls and thermostat are compatible and wired properly.
- ☑ Relocate the room thermostat if it is located in position that is too warm.

If condition space overheats:

- ☑ Verify the electric heater controls and room thermostat are compatible and wired properly.
- ☑ Relocate the room thermostat if it is located in position that is too cold.
- ☑ Verify the air distribution to the space is appropriate for the required thermal load.

Specific Electric Heater Troubleshooting Procedures:

Problem	Cause	Solution
Heater does not energize	Power not properly connected to the heater	<ol style="list-style-type: none"> 1. With a voltmeter, check the power wiring terminals to ensure proper voltage is available to the heater element side of the power terminal block or to the field side of the disconnect switch, power fusing or circuit breaker. 2. If proper voltage is not present, check the terminal studs for proper wiring and check power source for power.
	Disconnect switch, toggle switch or circuit breaker are set to OFF position	<ol style="list-style-type: none"> 1. Set disconnect switch, toggle switch or circuit breaker to ON position.
	Power fuses are blown or circuit breaker is tripped	<ol style="list-style-type: none"> 1. Replace fuse(s) with same type and amperage as those provided with the heater from the manufacturer or reset circuit breaker by first setting circuit breaker to OFF position then resetting to ON position. 2. With an ammeter, check amp draw on the power lines. 3. For heaters with fusing, amp draw should not exceed the fuse amperage. 4. Amp draw should not exceed the circuit breaker rated value. 5. If the amp draw is excessive, check the power supply as described above for power voltage. 6. If fuses blow or circuit breaker trips again, check for a short. 7. If no short is present and the power supply wiring/voltage are correct, contact factory for further assistance.
	Manual reset safety switch has tripped	<ol style="list-style-type: none"> 1. Push the reset safety button on back of safety reset. The manual safety reset is located inside the control enclosure cover near the bottom on the heater element header.
	Air flow/static switch is not engaging	<ol style="list-style-type: none"> 1. Jumper out the air flow/static switch by connecting the lead attached to the normally open terminal to the normally close terminal. 2. If the heater starts operating, two conditions could exist. <ol style="list-style-type: none"> A. The air flow/static switch may be defective. B. There is insufficient air flow to make the switch. 3. To verify available static pressure, disconnect the pneumatic tubing from the HI side of the air flow/static switch and connect to a magnehelic gauge. 4. Available static pressure should be 0.05 + or – 0.03" or 0.08" wc to be safe. 5. If available static pressure is in a dead band, between the two ranges, the air flow/static switch will not engage and could cause chattering of the contacts. Some method must be devised to increase the available static pressure. 6. If sufficient static pressure is available, check to ensure the pneumatic tubing is connected to the correct port (HI) on the air flow/static switch.
	Automatic Safety Reset Switch is bad	<ol style="list-style-type: none"> 1. Allow the duct temperature to cool down below 90° F. 2. If the heater still does not energize, jumper out the automatic safety reset switch. 3. If the heater now energizes, contact the factory for a replacement automatic safety reset switch.

Specific Electric Heater Troubleshooting Procedures (Cont.):

Problem	Cause	Solution
	Manual Safety Reset Switch is bad	<ol style="list-style-type: none"> 1. Allow the duct temperature to cool down below 90° F. 2. If the heater still does not energize, perform the following. 3. On heaters with the manual safety reset switch connected in the backup contact circuit, jumper out the manual safety reset switch. 4. If the backup contractor now engages, contact the factory for a replacement manual safety reset switch. 5. If the backup contractor fails to engage, there is a problem in the backup contractor holding coil. 6. Use an ohmmeter to check continuity of the holding coil on the backup contractor. 7. If bad, contact factory for replacement backup contractor.
	Insufficient air flow across the electric heating elements	<ol style="list-style-type: none"> 1. Then minimum allowable air flow across the heating elements is 70 CFM/kW. 2. Unless this recommended minimum air flow is met, the leaving air temperature of the heater will be greater than the safety reset switches limits. This will cause nuisance tripping of the safety reset switch. 3. Reset the minimum air flow across the heating elements during a call for heat at 70 CFM/kW.



Warning: On all troubleshooting that requires working inside the heater casing, disconnect the power first!
 Jumpers used for diagnostic purposes should be removed before returning the heater to normal operation.

Figure 3

MULTI-QUADRANT AVERAGING FLOW SENSOR

MODEL	INLET SIZE	K FACTOR
XG-TH, XG-FCL, XG-FCQ XG-FVI, XG-DD XG-DH, XG-BP XG-RT, XG-RA XG-TL (4 TO 10) XG-FCL C2 (4 TO 8) XG-FVL C2 (4 TO 8)	04 Rnd	300
	05 Rnd	375
	06 Rnd	540
	07 Rnd	760
	08 Rnd	990
	09 Rnd	1250
	10 Rnd	1640
	12 Rnd	2350
	14 Rnd	3250
	16 Rnd	4100
XG-TL (12)	12 Flat Oval	2270
XG-TL(14) & XG-FVL C6	14 Flat Oval	2850
XG-TL (16)	16 Flat Oval	3550
XG-FVL C4	14x8 Rect	2450
XG-FCL C4	16x8 Rect	2770
XG-FCI, XG-FCQ, & XG-FVI C7	18x16 Rect	6200
XG-TH 20	20x16 Rect	6430
XG-TH 24	24x16 Rect	7270

Note: K-factor is the calibration flow constant at 1" w.g. delta P

Rnd

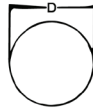

SIZE	D (in.)
04 Rnd	4
05 Rnd	5
06 Rnd	6
07 Rnd	7
08 Rnd	8
09 Rnd	9
10 Rnd	10
12 Rnd	12
14 Rnd	14
16 Rnd	16

Flat Oval

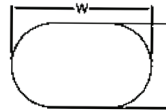

SIZE	W (in.)	H (in.)
12 Flat Oval	13	10
14 Flat Oval	16.25	10
16 Flat Oval	16.25	10

Rect

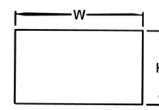

SIZE	W (in.)	H (in.)
14x8 Rect	14	10
16x8 Rect	16	10
20x16 Rect	20	10
24x16 Rect	24	16

$$Cfm = \sqrt{\Delta p} \times K \text{ Factor}$$

