

Installation, Operation and Maintenance Manual

Please read and save these instructions for future reference. Read carefully before attempting to assemble, install, operate or maintain the product described. Protect yourself and others by observing all safety information. Failure to comply with these instructions will result in voiding of the product warranty and may result in personal injury and/or property damage.



XG-Round Retrofit VAV Terminals

Receiving Inspection

Prior to removing the shipping materials, visually inspect the packing materials. There should be a black plastic strip wrapped in the clear plastic stretch wrap. If this black plastic strip is missing, the shipment may have been repacked by the shipper and you should make a note of this on the shipping documents and inform the delivering carrier.

After unpacking the terminals, check for shipping damage. If any shipping damage is found, report it immediately to the delivering carrier.

Always store the product in a clean dry location prior to installation.

Units with controls are not recommended for use in ambient temperatures greater than 95° F. For protection of controls, do not store in temperatures above 135°F.

Caution: Do not use the flow sensor, connecting tubing or damper shaft as a lift point. Damage to the components may result.

Hanging/Installation Requirements

- ☑ Unless local building codes require hangers, the basic XG-Round Retrofit Air Terminals may be light enough to be supported by the ductwork itself.
- ☑ Straps or the method prescribed for round duct on the job specification may be used. *(See figure 1)*
- ☑ Trapeze hangers or the method prescribed for round duct on the job specification may be used. *(See figure 2)*

Note: XG-Round Retrofit Air Terminals are not designed nor suitable for outdoor use.

In advance of startup, verify all electrical connections are tight and that the correct voltage is supplied to the XG-Round Retrofit Air Terminal per the voltage listed on the label. If factory supplied controls are present, review all wiring diagrams for complete working knowledge.

Figure 1 Hanging Straps

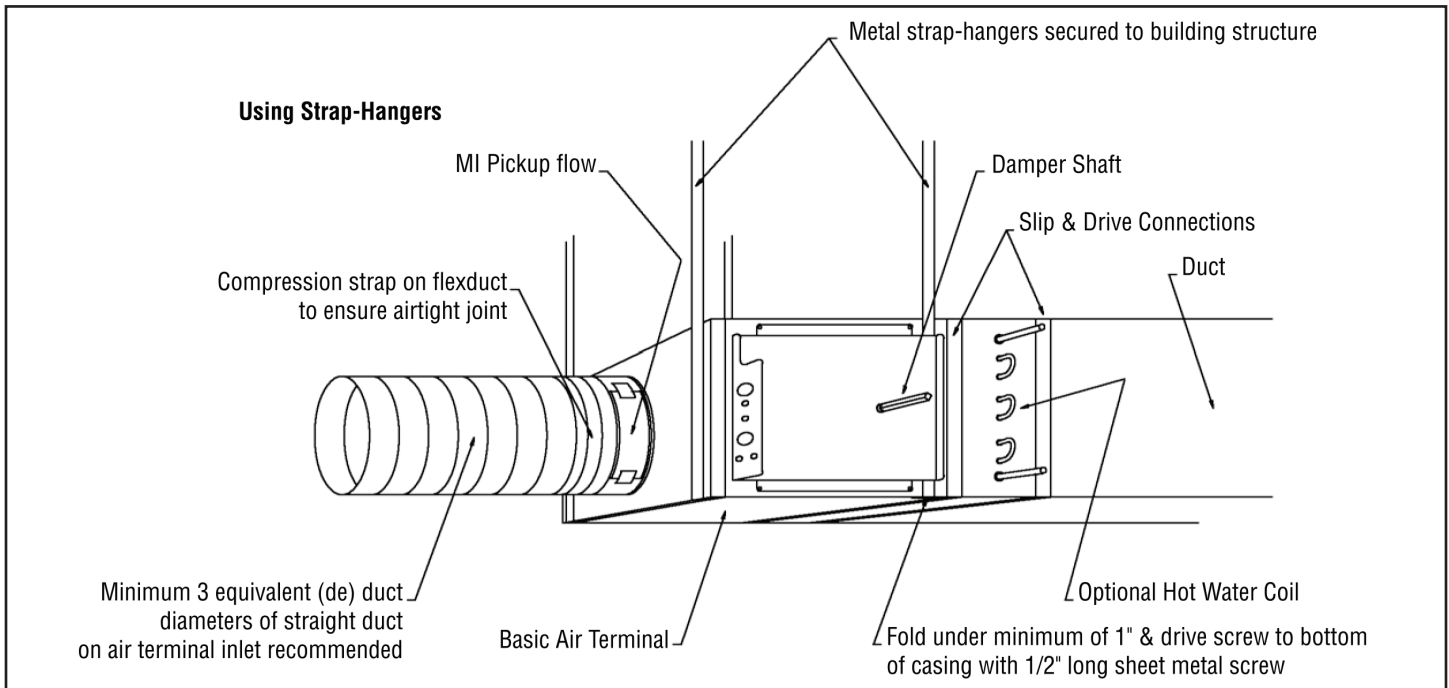
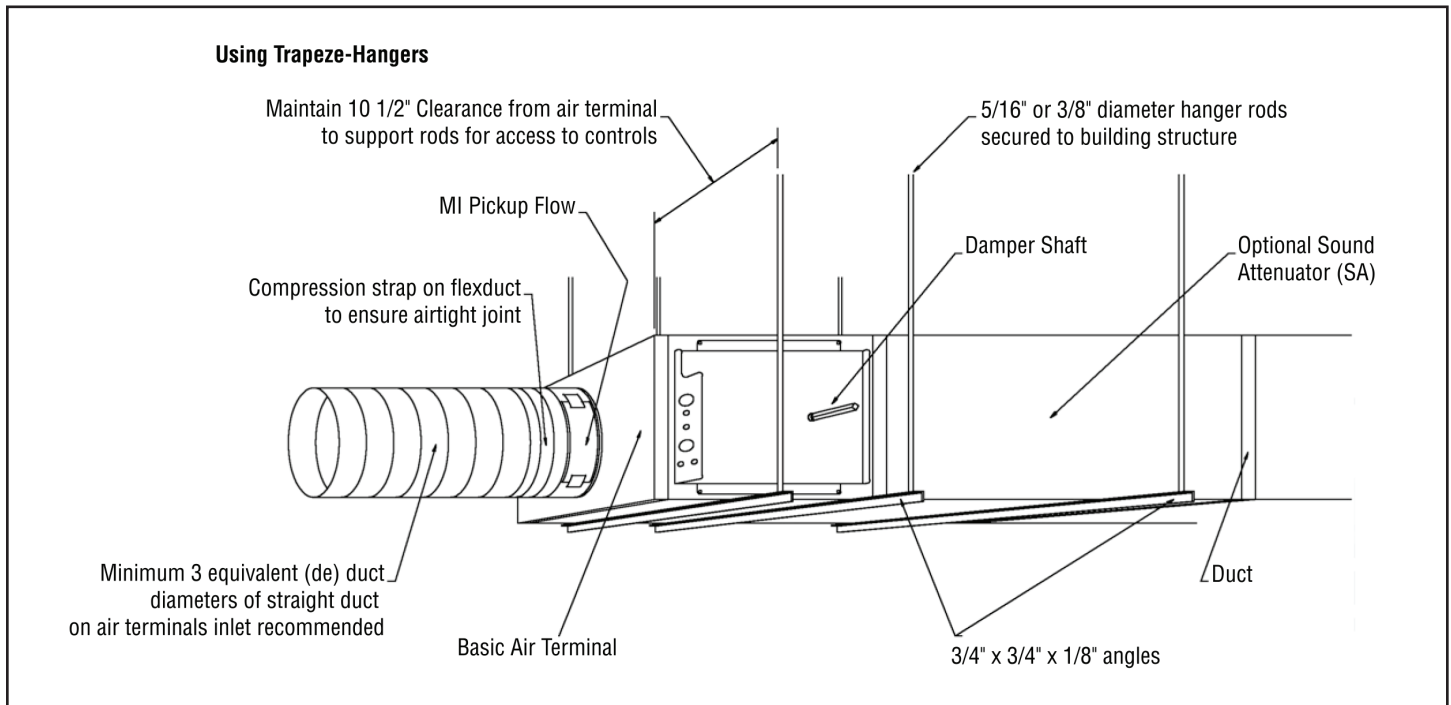

Figure 2 Trapeze



Minimum Clearance for Access

Dual Duct Air Terminals require sufficient space to allow servicing of the controls. Horizontal clearance requirements are dependent upon access panel dimensions which are indicated on the appropriate submittal. For control panel access, a minimum of 18" is recommended. See the appropriate submittal for control panel location.

Note: These clearances recommendations are not meant to preclude NEC requirements or local building codes that may be applicable, which are the responsibility of the installing contractor.

Connecting Duct Work

1. Slip each inlet duct over the inlet collar of the XG-Round Retrofit Air Terminal.
2. Fasten and seal the connection by method prescribed by job specification.
3. The diameter of the inlet duct in inches, must be equal to the listed size of the XG-Round Retrofit Air Terminal; e.g. a duct that actually measures 8 inches must be fitted to a size 8 inch Air Terminal. The inlet tube of the XG-Round Retrofit Air Terminal is manufactured 1/8" smaller than the listed size in order to fit inside the duct.

Note: Do not insert duct work inside the inlet collar of the XG-Round Retrofit Air Terminal. Inlet duct should be installed in accordance with SMACNA guidelines.

4. If an inlet air flow sensor is installed, it is recommended the installer provide a minimum of 3 duct diameters of straight duct at the XG-Round Retrofit Air Terminal inlet.
5. The outlet end of the XG-Round Retrofit Air Terminal is designed for use with the same duct connections as the inlet.

Field Electrical Wiring

- ☑ All field wiring must comply with local building codes and NEC. (ANSI/NFPA 70-2002)
- ☑ When Applicable, electrical control and piping diagrams are attached to exterior of XG-Round Retrofit Air Terminal.
- ☑ Use copper only conductors.
- ☑ XG-Round Retrofit Air Terminal must be properly grounded per NEC 424-14 and 250.
- ☑ Always check product label for voltage and current data to determine the proper wire size and over current protection.
- ☑ The control cabinet contains live electrical parts.
- ☑ Contacting these parts with power applied may cause serious injury or even death.
- ☑ The control panel cover must be closed or in place before applying electric power to the XG-Round Retrofit Air Terminal.
- ☑ These recommendations are not meant to preclude NEC requirements or applicable local building codes and are the sole responsibility of the installing contractor.

Important

If equipped with pneumatic controls, the orientation of the XG-Round Retrofit Air Terminal unit is critical. The pneumatic controls must be mounted right side up. The XG-Round Retrofit Air Terminal must be level within + or - 10 degrees of horizontal, both parallel to the air flow and at right angle of air flow. The control side of the XG-Round Retrofit Air Terminal is labeled with an arrow indicating up. Unless otherwise noted, most electric, analog electronic and digital are not position sensitive and may be installed in any orientation.

Controls

For information on controls provided by other manufactures and installed on the XG-Round Retrofit Air Terminals, contact the local branch or dealer. Installing the Air Terminal in a different location than noted on the XG-Round Retrofit Air Terminal label and building plans, may result in excessive start up labor and is the sole responsibility of the contractor.

Important

XG-Round Retrofit Air Terminals with digital controls, if factory programmed, incorporate specific communication addresses.

Inlet Flow Sensor

XG-Round Retrofit Air Terminals are shipped with factory installed (where applicable) pressure differential inlet flow sensors in the primary inlet. **See figure 3** for calibration curve and K factors.

Labeling

XG-Round Retrofit Air Terminals are shipped from the factory with multiple information labels.

Control Sequence Label: Affixed to the exterior of the XG-Round Retrofit Air Terminal casing. Displays piping/wiring diagram, control sequence number and any optional components.

Terminal I.D. Label: Affixed to the exterior of XG-Round Retrofit Air Terminal. Shows tagging, representative name, sales order number, applicable certifications, model number, Made in USA, any applicable electrical data and UL compliance markings.

AHRI Certification Label: Identifies applicable industry test standard and certifies Air Terminal is in compliance.

Orientation Label: Identifies the proper air flow direction and top of Round Retrofit Air Terminal.

Troubleshooting

Investigating Noise Complaints

- ☑ Noise from a Round Retrofit Air Terminal can be due to a variety of conditions and can be difficult to eliminate.
- ☑ The first step is to isolate the type, source and direction.
- ☑ Generally noise heard at the air outlet is considered a discharge type.
- ☑ Noise heard through the ceiling is considered radiated noise.
- ☑ For detailed information concerning noise transmission in buildings, refer to AHRI Standard 885-2008, "Procedure for estimating occupied space sound levels in the application of Air Terminals and air outlets".

Discharge Noise

- ☑ This is usually caused by high static or little to no internal duct lining downstream of the Round Retrofit Air Terminal.
- ☑ It can sometimes be caused by air outlet itself.
- ☑ Air outlet generated sounds can be reduced by reducing flow or increasing an outlet size.
- ☑ Reducing static pressure, flow or adding additional downstream attenuation materials will reduce discharge sounds from the Air Terminal.

Radiated Noise

- ☑ Radiated noise is most commonly associated with Fan Powered Terminals.

Figure 3
MULTI-QUADRANT AVERAGING FLOW SENSOR

MODEL	INLET SIZE	K FACTOR
XG-TH, XG-FCL, XG-FCQ XG-FVI, XG-DD XG-DH, XG-BP XG-RT, XG-RA XG-TL (4 TO 10) XG-FCL C2 (4 TO 8) XG-FVL C2 (4 TO 8)	04 Rnd	300
	05 Rnd	375
	06 Rnd	540
	07 Rnd	760
	08 Rnd	990
	09 Rnd	1250
	10 Rnd	1640
	12 Rnd	2350
	14 Rnd	3250
	16 Rnd	4100
XG-TL (12)	12 Flat Oval	2270
XG-TL(14) & XG-FVL C6	14 Flat Oval	2850
XG-TL (16)	16 Flat Oval	3550
XG-FVL C4	14x8 Rect	2450
XG-FCL C4	16x8 Rect	2770
XG-FCI, XG-FCQ, & XG-FVI C7	18x16 Rect	6200
XG-TH 20	20x16 Rect	6430
XG-TH 24	24x16 Rect	7270

Note: K-factor is the calibration flow constant at 1" w.g. delta P

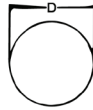
Rnd

SIZE	D (in.)
04 Rnd	4
05 Rnd	5
06 Rnd	6
07 Rnd	7
08 Rnd	8
09 Rnd	9
10 Rnd	10
12 Rnd	12
14 Rnd	14
16 Rnd	16

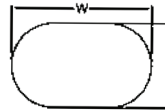
Flat Oval

SIZE	W (in.)	H (in.)
12 Flat Oval	13	10
14 Flat Oval	16.25	10
16 Flat Oval	16.25	10

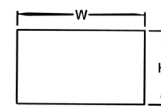
Rect

SIZE	W (in.)	H (in.)
14x8 Rect	14	10
16x8 Rect	16	10
20x16 Rect	20	10
24x16 Rect	24	16

$$Cfm = \sqrt{\Delta p} \times K \text{ Factor}$$

