

Model: XG-SG2000-1 0°, 15° and 30° Deflection Blades - No Sleeve - Flush Surface Mount

XG-SG2000-1 - Minimum Security Grille

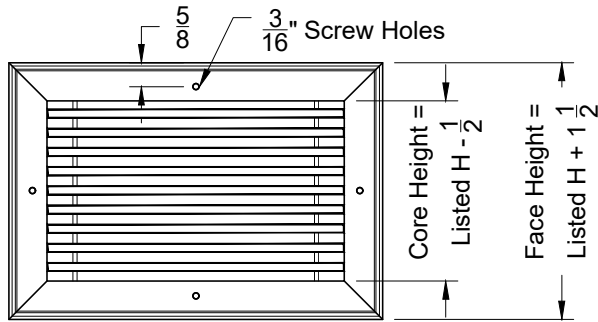

Face View

Lengths Up To 12

4 Holes One Each Side Centered

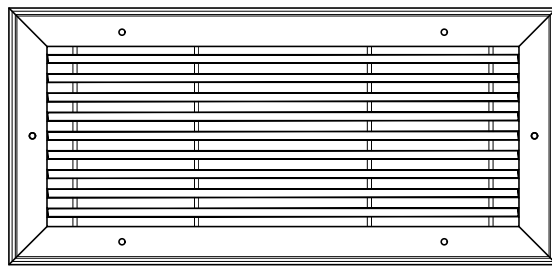

Lengths Over 12" Up to 36"

6 Holes 1 Each End Centered, 2 Holes Each Side, 4" From End

Face View

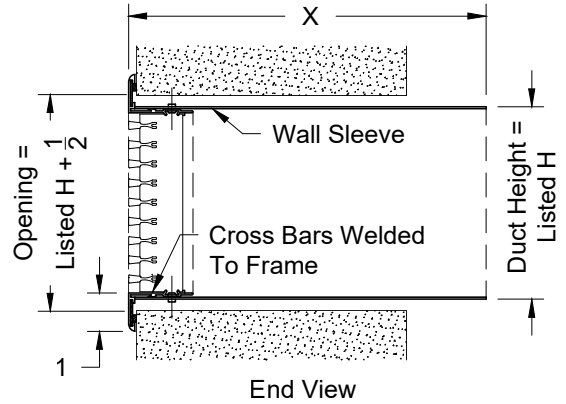

End View

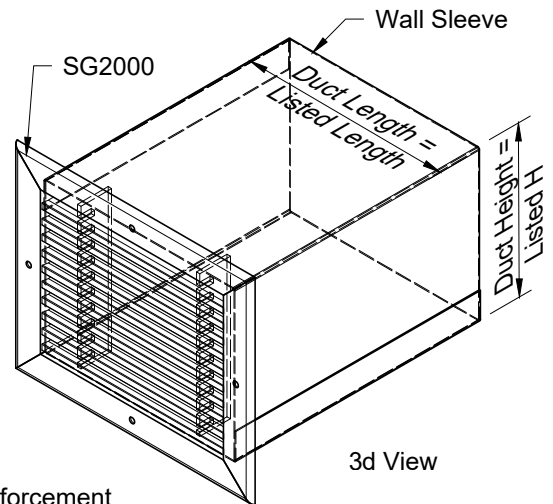

3d View

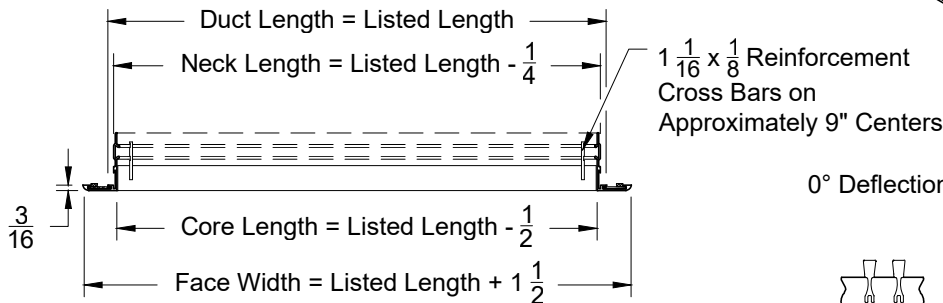

Top View

0° Deflection 15° Deflection 30° Deflection

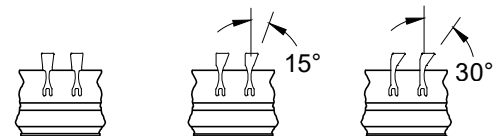

1. Available Finishes	2. Available Accessories	3. Available Options	4. Construction Details
Standard Finish: 01 White Finish 24 Mill Finish Optional Finish 02 Satin Silver 03 Black 04 Anodized 28 Custom Color	XG-OBD - Steel Opposed Blade Damper XG-OBDA - Aluminum OBD Note: Dampers installed on security grilles will be rear operated		<ul style="list-style-type: none"> • Odd/Fractional Sizes Available for additional charge • Oversized Units made in multiple sections • Largest single section is 48x48 • Mullion strips provided for joining units in field • X = Sleeve Length (Must be specified) All Dimensions ±1/16"

Model: XG-SG2000-2 0°, 15° and 30° Deflection Blades - Steel Sleeve - Flush Surface Mount

XG-SG2000-2 - Medium Security Grille

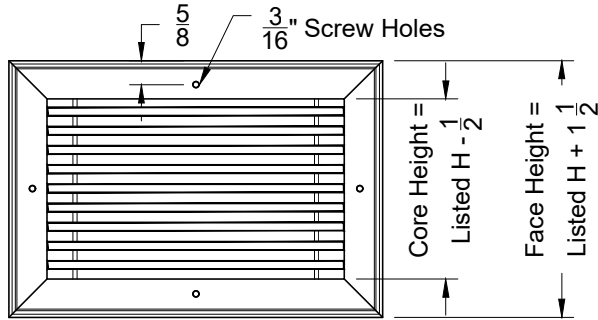

Face View

Lengths Up To 12

4 Holes One Each Side Centered

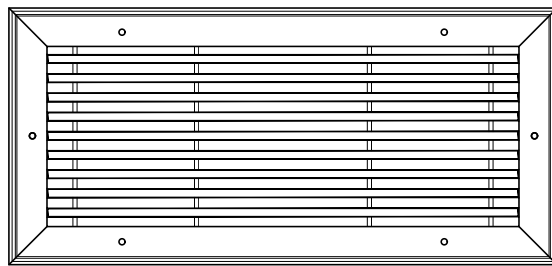

Lengths Over 12" Up to 36"

6 Holes 1 Each End Centered, 2 Holes Each Side, 4" From End

Face View

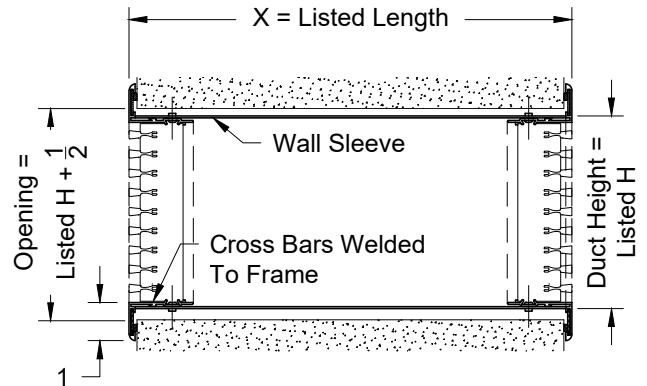

End View

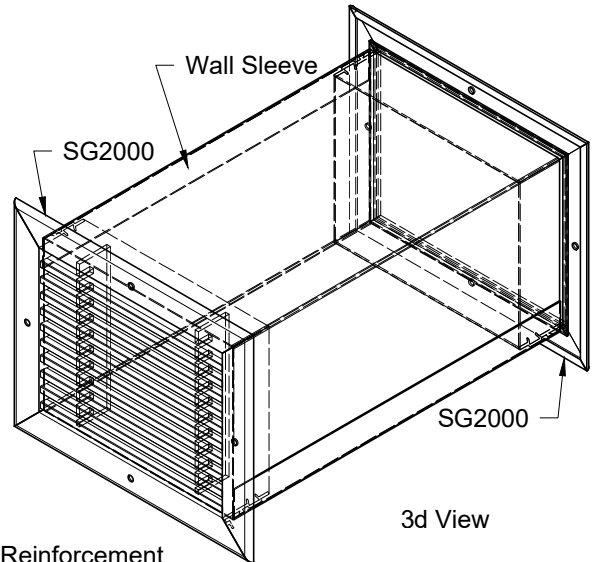

3d View

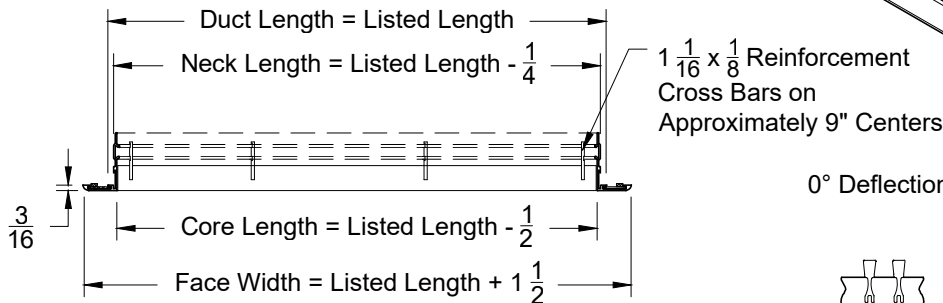

Top View

0° Deflection 15° Deflection 30° Deflection

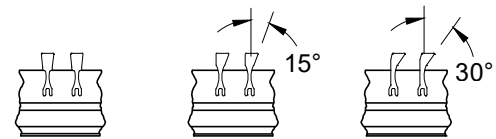

1. Available Finishes	2. Available Accessories	3. Available Options	4. Construction Details
Standard Finish: 01 White Finish 24 Mill Finish Optional Finish 02 Satin Silver 03 Black 04 Anodized 28 Custom Color	XG-OBD - Steel Opposed Blade Damper XG-OBDA - Aluminum OBD Note: Dampers installed on security grilles will be rear operated		<ul style="list-style-type: none"> • Odd/Fractional Sizes Available for additional charge • Oversized Units made in multiple sections • Largest single section is 48x48 • Mullion strips provided for joining units in field • X = Sleeve Length (Must be specified) All Dimensions ±1/16"