

Model: XG-SGLF-10 Lattice Face 1" x 1" - Surface Mount

XG-SGLF-10 - Surface Mount

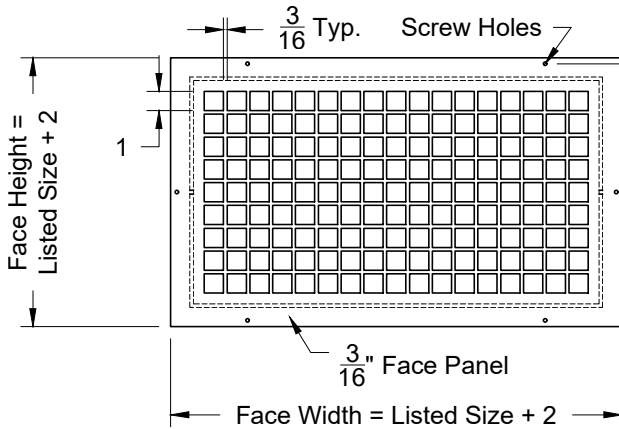

Face View

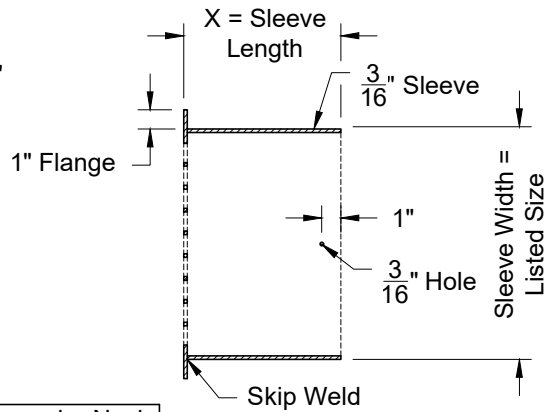

Side View

Rectangular Neck Sizes Available	
Min	Max
6	48

Sleeve Lengths Available	
Min	Max
4	16

Options

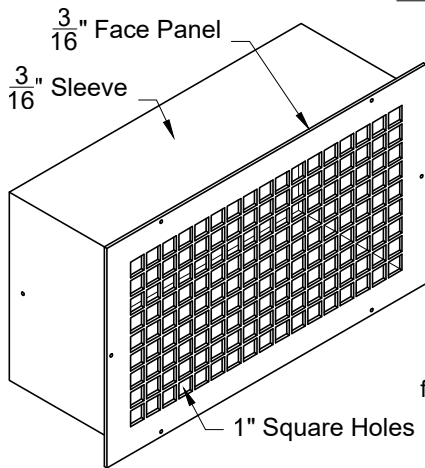

3d View

SAB

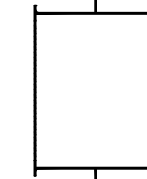

$\frac{1}{2}$ " Diameter Bar
3" Long
for concrete block or brick wall

SBR

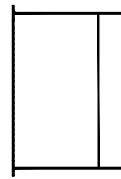

$\frac{1}{2}$ " Diameter Bar
Spaced on 6" centers
Welded to sleeve

LSA

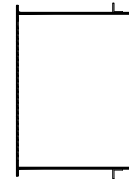

(4) L-Shaped angles
 $1" \times 1" \times \frac{3}{16}"$
Shipped loose for field welding

BSA

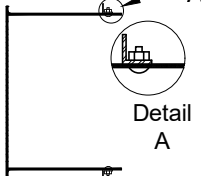

(4) L-Shaped angles
 $1" \times 1" \times \frac{3}{16}"$
Shipped with mounting holes
Hardware provided by others

WSA

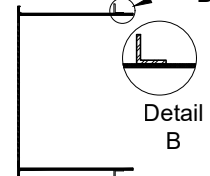

(4) L-Shaped angles
 $1" \times 1" \times \frac{3}{16}"$
Shipped welded to sleeve

WAF

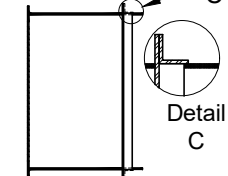

Welded Angle Frame 4-Sided
 $1" \times 1" \times \frac{3}{16}"$
Shipped loose for field welding

1. Available Finishes

Finish
Standard Finish:
01 White
Optional Finish
02 Satin Silver
03 Black
28 Custom Color

2. Available Accessories

XG-OBD - Steel Opposed Blade Damper
XG-OBDA - Aluminum OBD
Note: Dampers installed on security grilles will be rear operated

3. Available Options

SH - Screw Holes
SBR - Security Bars
SAB - Steel Anchor Bar
WAF - Welded Angle Frame

WSA - Welded Steel Angle
BSA - Bolted Steel Angle
LSA - Loose Steel Angle

4. Construction Details

- Face Plate is $\frac{3}{16}$ " Thick
- Dimension Type:
Nominal or Actual
- X = Sleeve Length
(Must be specified)
- Face Operated Damper not recommended

All Dimensions $\pm 1/16"$

Model: XG-SGLF-13 Lattice Face 13/16" x13/16" - Surface Mount

XG-SGLF-13 - Surface Mount

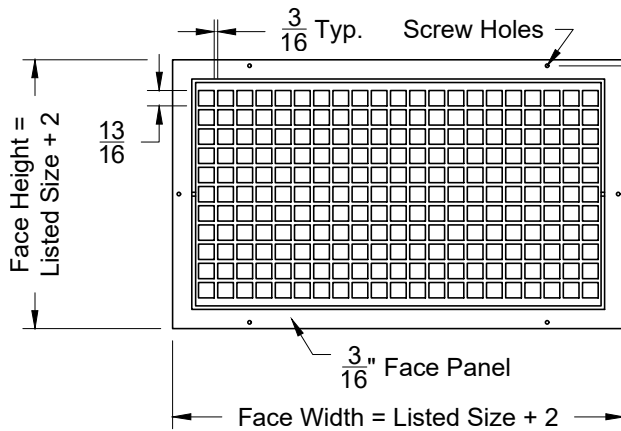

Face View

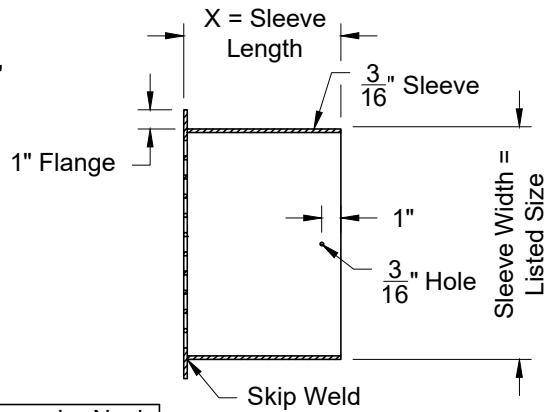

Side View

Rectangular Neck Sizes Available	
Min	Max
6	48

Sleeve Lengths Available	
Min	Max
4	16

Options

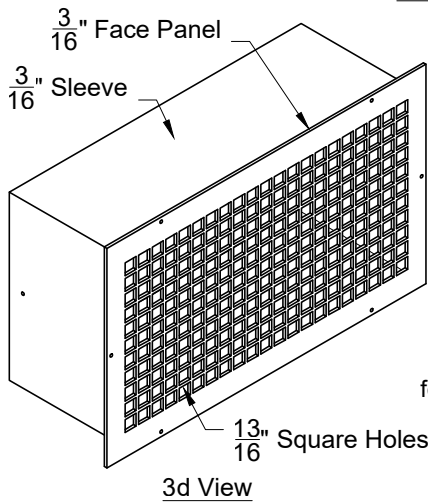

3d View

SAB

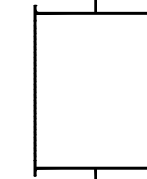

1/2" Diameter Bar
3" Long
for concrete block or brick wall

SBR

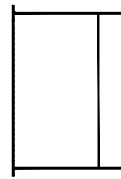

1/2" Diameter Bar
Spaced on 6" centers
Welded to sleeve

LSA

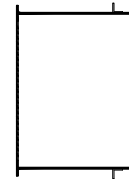

(4) L-Shaped angles
1" x 1" x 3/16"
Shipped loose for field welding

BSA

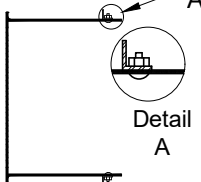

(4) L-Shaped angles
1" x 1" x 3/16"
Shipped with mounting holes
Hardware provided by others

WSA

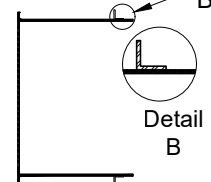

(4) L-Shaped angles
1" x 1" x 3/16"
Shipped welded to sleeve

WAF

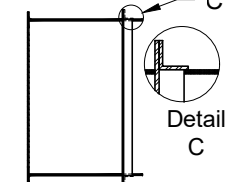

Welded Angle Frame 4-Sided
1" x 1" x 3/16"
Shipped loose for field welding

1. Available Finishes	2. Available Accessories	3. Available Options	4. Construction Details
Finish Standard Finish: 01 White Optional Finish 02 Satin Silver 03 Black 28 Custom Color	XG-OBD - Steel Opposed Blade Damper XG-OBDA - Aluminum OBD Note: Dampers installed on security grilles will be rear operated	SH - Screw Holes SBR - Security Bars SAB - Steel Anchor Bar WAF - Welded Angle Frame WSA - Welded Steel Angle BSA - Bolted Steel Angle LSA - Loose Steel Angle	<ul style="list-style-type: none"> Face Plate is 3/16" Thick Dimension Type: Nominal or Actual X = Sleeve Length (Must be specified) Face Operated Damper not recommended <p style="text-align: right;">All Dimensions ±1/16"</p>

Model: XG-SGLF-50 Lattice Face 1/2" x 1/2" - Surface Mount

XG-SGLF-50 - Surface Mount

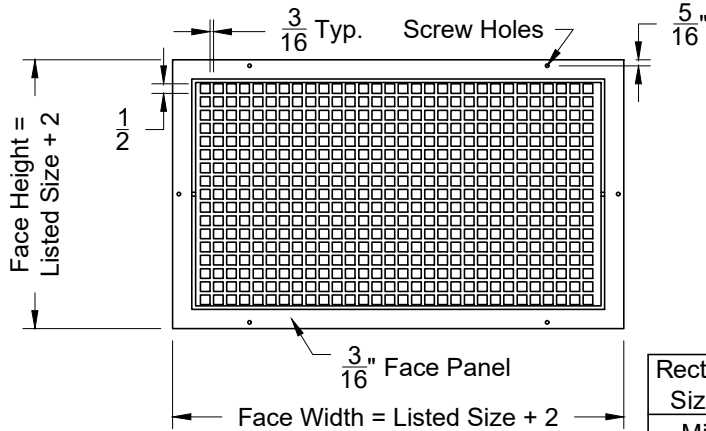

Face View

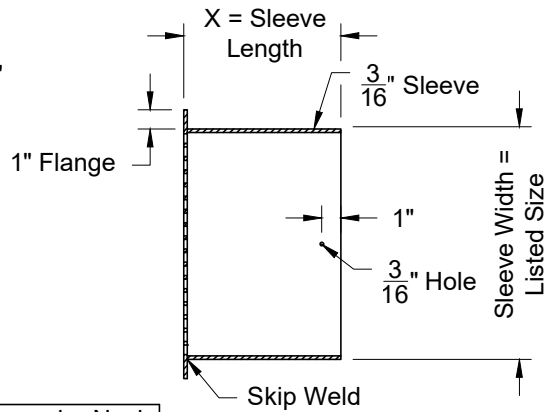

Side View

Rectangular Neck Sizes Available	
Min	Max
6	48

Sleeve Lengths Available	
Min	Max
4	16

Options

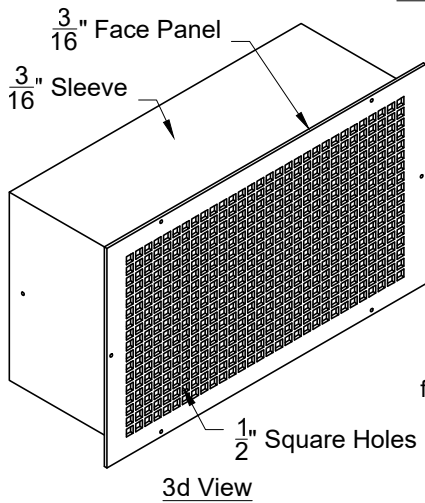

3d View

SAB



1/2" Diameter Bar
3" Long
for concrete block or brick wall

SBR

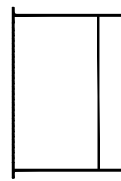

1/2" Diameter Bar
Spaced on 6" centers
Welded to sleeve

LSA

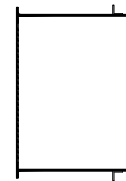

(4) L-Shaped angles
1" x 1" x 3/16"
Shipped loose for field welding

BSA

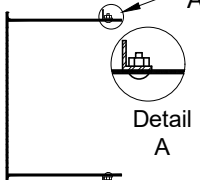

(4) L-Shaped angles
1" x 1" x 3/16"
Shipped with mounting holes
Hardware provided by others

WSA

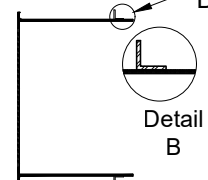

(4) L-Shaped angles
1" x 1" x 3/16"
Shipped welded to sleeve

WAF

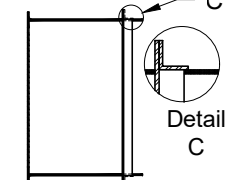

Welded Angle Frame 4-Sided
1" x 1" x 3/16"
Shipped loose for field welding

1. Available Finishes	2. Available Accessories	3. Available Options	4. Construction Details
Finish Standard Finish: 01 White Optional Finish 02 Satin Silver 03 Black 28 Custom Color	XG-OBDA - Steel Opposed Blade Damper XG-OBDA - Aluminum OBD Note: Dampers installed on security grilles will be rear operated	SH - Screw Holes SBR - Security Bars SAB - Steel Anchor Bar WAF - Welded Angle Frame WSA - Welded Steel Angle BSA - Bolted Steel Angle LSA - Loose Steel Angle	<ul style="list-style-type: none"> Face Plate is 3/16" Thick Dimension Type: Nominal or Actual X = Sleeve Length (Must be specified) Face Operated Damper not recommended
All Dimensions ±1/16"			

Model: XG-SGLF-75 Lattice Face 3/4" x 3/4" - Surface Mount

XG-SGLF-75 - Surface Mount

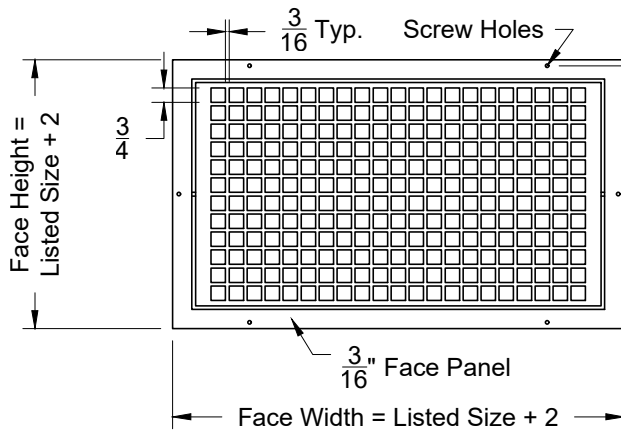

Face View

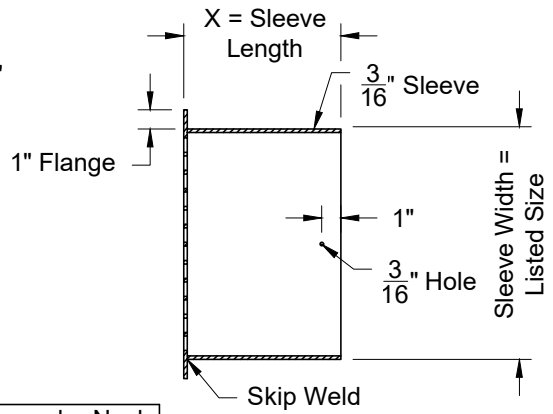

Side View

Rectangular Neck Sizes Available	
Min	Max
6	48

Sleeve Lengths Available	
Min	Max
4	16

Options

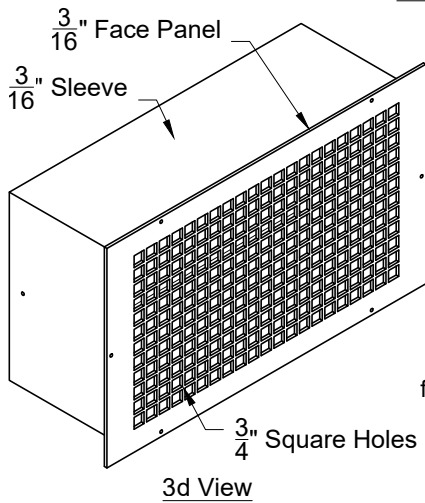

3d View

SAB

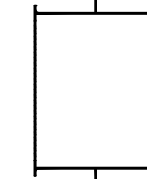

1/2" Diameter Bar
3" Long
for concrete block or brick wall

SBR

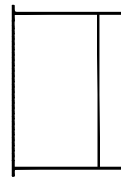

1/2" Diameter Bar
Spaced on 6" centers
Welded to sleeve

LSA

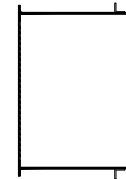

(4) L-Shaped angles
1" x 1" x 3/16"
Shipped loose for field welding

BSA

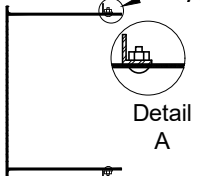

(4) L-Shaped angles
1" x 1" x 3/16"
Shipped with mounting holes
Hardware provided by others

WSA

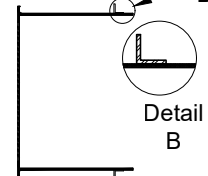

(4) L-Shaped angles
1" x 1" x 3/16"
Shipped welded to sleeve

WAF

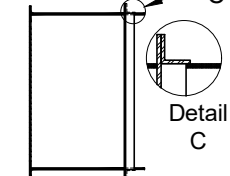

Welded Angle Frame 4-Sided
1" x 1" x 3/16"
Shipped loose for field welding

1. Available Finishes

Finish
Standard Finish:
01 White
Optional Finish
02 Satin Silver
03 Black
28 Custom Color

2. Available Accessories

XG-OBD - Steel Opposed Blade Damper
XG-OBDA - Aluminum OBD
Note: Dampers installed on security grilles will be rear operated

3. Available Options

SH - Screw Holes
SBR - Security Bars
SAB - Steel Anchor Bar
WAF - Welded Angle Frame

WSA - Welded Steel Angle
BSA - Bolted Steel Angle
LSA - Loose Steel Angle

4. Construction Details

- Face Plate is 3/16" Thick
- Dimension Type:
Nominal or Actual
- X = Sleeve Length
(Must be specified)
- Face Operated Damper not recommended

All Dimensions ±1/16"