

Minimum Security Aluminum Grille

Models: **XG-SGRP-SR-AL** Minimum Security Aluminum Grille Suicide Deterrent Perforated Face

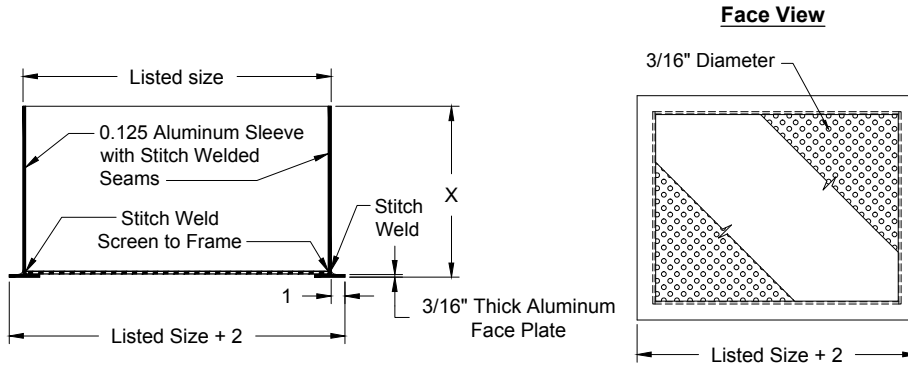

X = Sleeve Length (Has to be specified)

Options

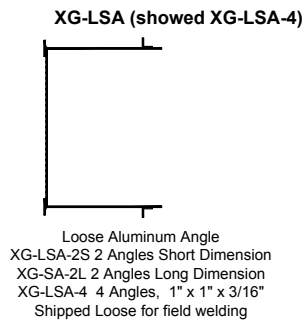
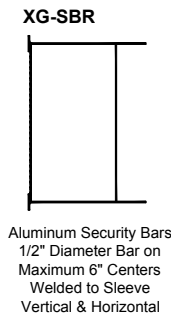
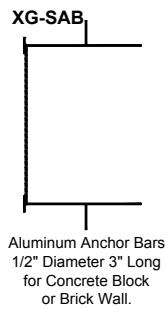
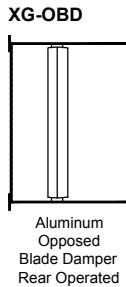

Mounting holes located 1" from edge
Holes in sleeve drilled where needed
Hardware provided by others (nuts/bolts)

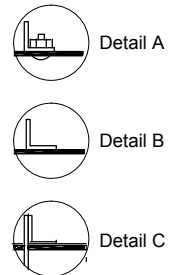
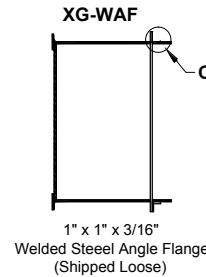
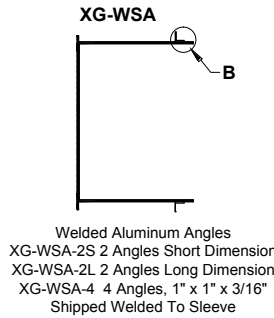
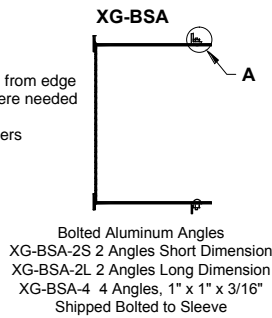

Notes: (check if provided)

1. Available Finishes	2. Available Accessories	3. Available Options	4. Construction Details
<p>Standard Finish: 01 White.</p> <p>Optional Finish No Charge: 24 Mill</p> <p>Optional Finish Extra Charge: 02 Satin Silver 03 Black 28 Special Color / Setup Charge</p>	<p>See Above</p>	<p>See Above</p>	<ul style="list-style-type: none"> .125 Plate aluminum face and sleeves XG-OBDA Can be face operated not recommended Seams can be continuously welded contact regional sales manager for availability and costs