

Installation, Operation and Maintenance Manual

Please read and save these instructions for future reference. Read carefully before attempting to assemble, install, operate or maintain the product described. Protect yourself and others by observing all safety information. Failure to comply with these instructions will result in voiding of the product warranty and may result in personal injury and/or property damage.



XG-Single Duct VAV Terminals

Receiving Inspection

Prior to removing the shipping materials, visually inspect the packing materials. There should be a black plastic strip wrapped in the clear plastic stretch wrap. If this black plastic strip is missing, the shipment may have been repacked by the shipper and you should make a note of this on the shipping documents and inform the delivering carrier.

After unpacking the terminals, check for shipping damage. If any shipping damage is found, report it immediately to the delivering carrier.

Always store the product in a clean dry location prior to installation.

Units with controls are not recommended for use in ambient temperatures greater than 95° F. For protection of controls, do not store in temperatures above 135°F.

Caution: Do not use the flow sensor, connecting tubing or damper shaft as a lift point. Damage to the components may result.

Hanging/Installation Requirements

- ☑ Unless local building codes require hangers, the smaller size basic Single Duct Terminals may be light enough to be supported by the ductwork itself. However, when accessory components such as a controls, hot water reheat coils, sound attenuators or electric reheat are included, the single duct terminal should be supported directly with straps screwed into the side of the terminal. (See figure 1)
- ☑ Alternate trapeze hangers or the method prescribed for the rectangular duct on the job specification may be used. (See figure 2)
- ☑ Single Duct Air Terminals may also be suspended with factory supplied and field installed hanger brackets and field supplied and installed hanger rods. (See figure 3)

Note:

Single Duct Terminals are not designed nor suitable for outdoor use.

In advance of startup, verify all electrical connections are tight and that the correct voltage is supplied to the Terminal per the voltage listed on the label. If factory supplied controls are present, review all wiring diagrams for complete working knowledge.

Figure 1 Hanging Straps

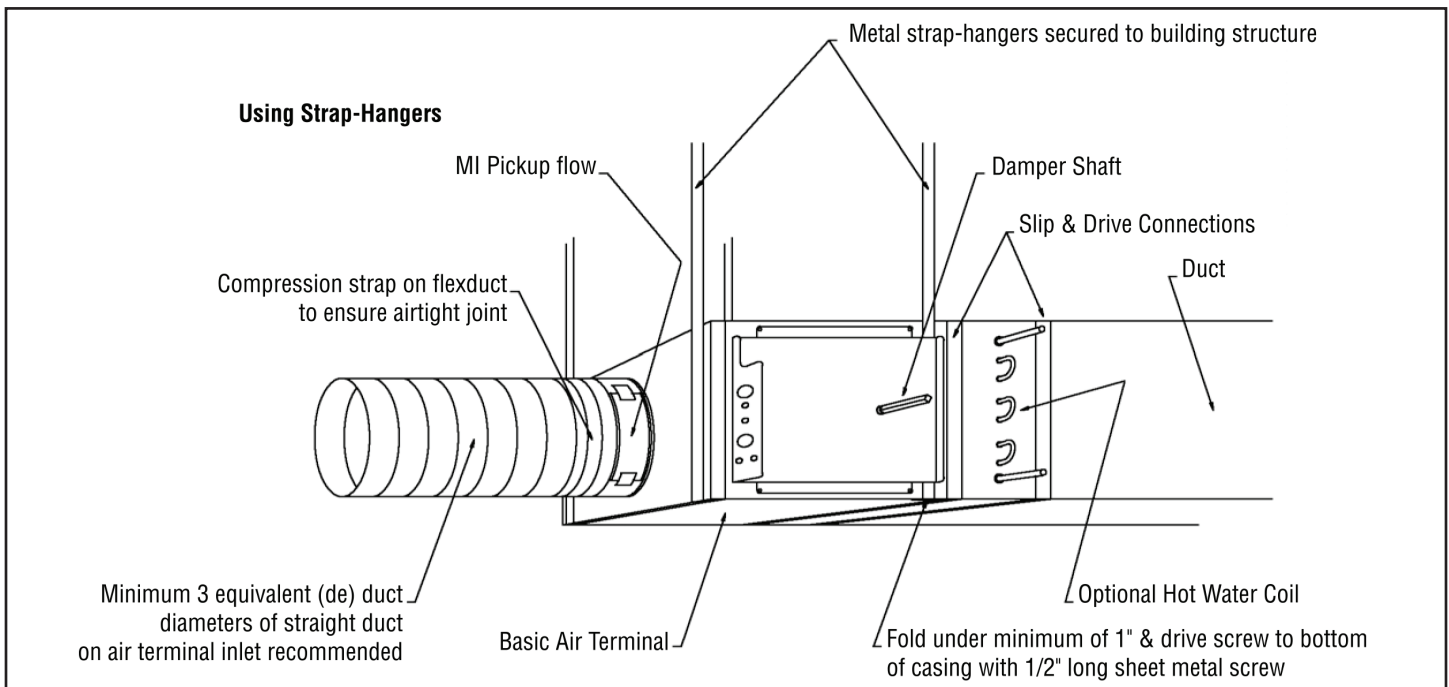

Figure 2 Trapeze

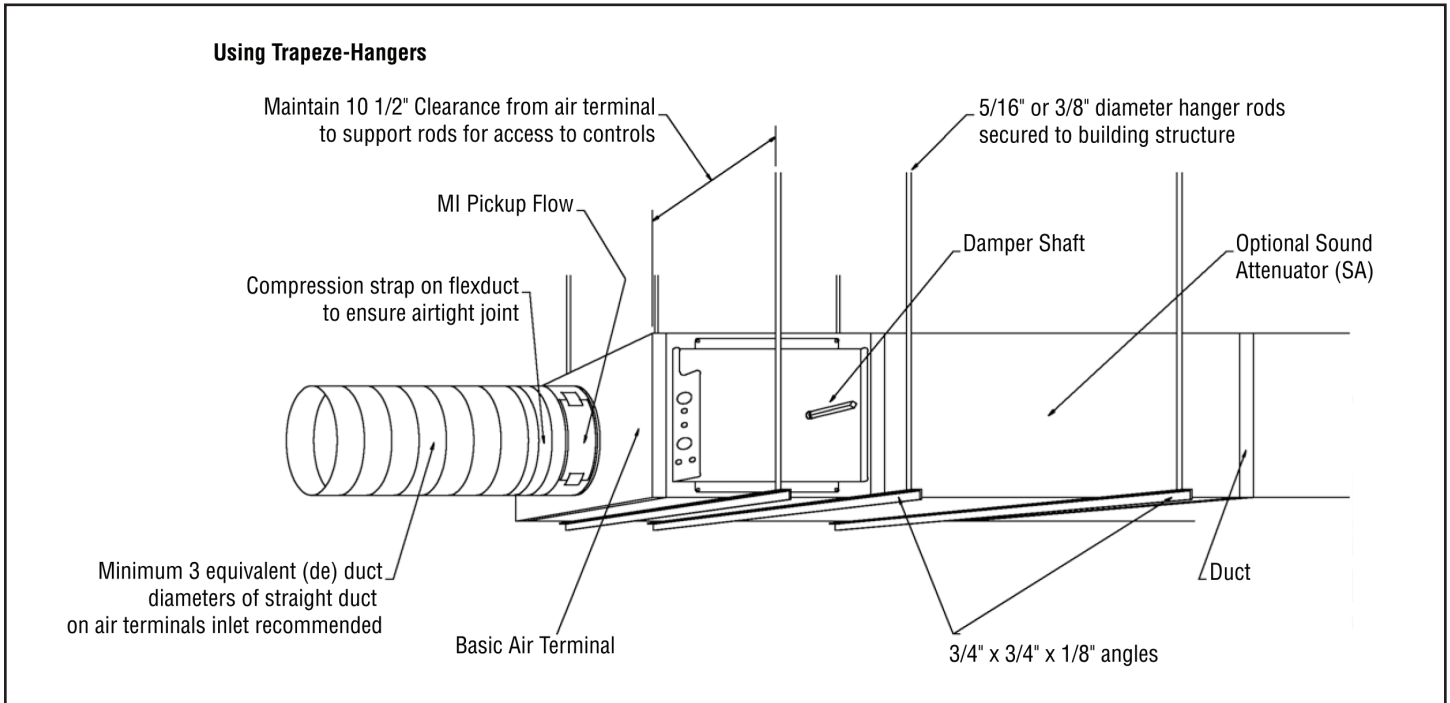
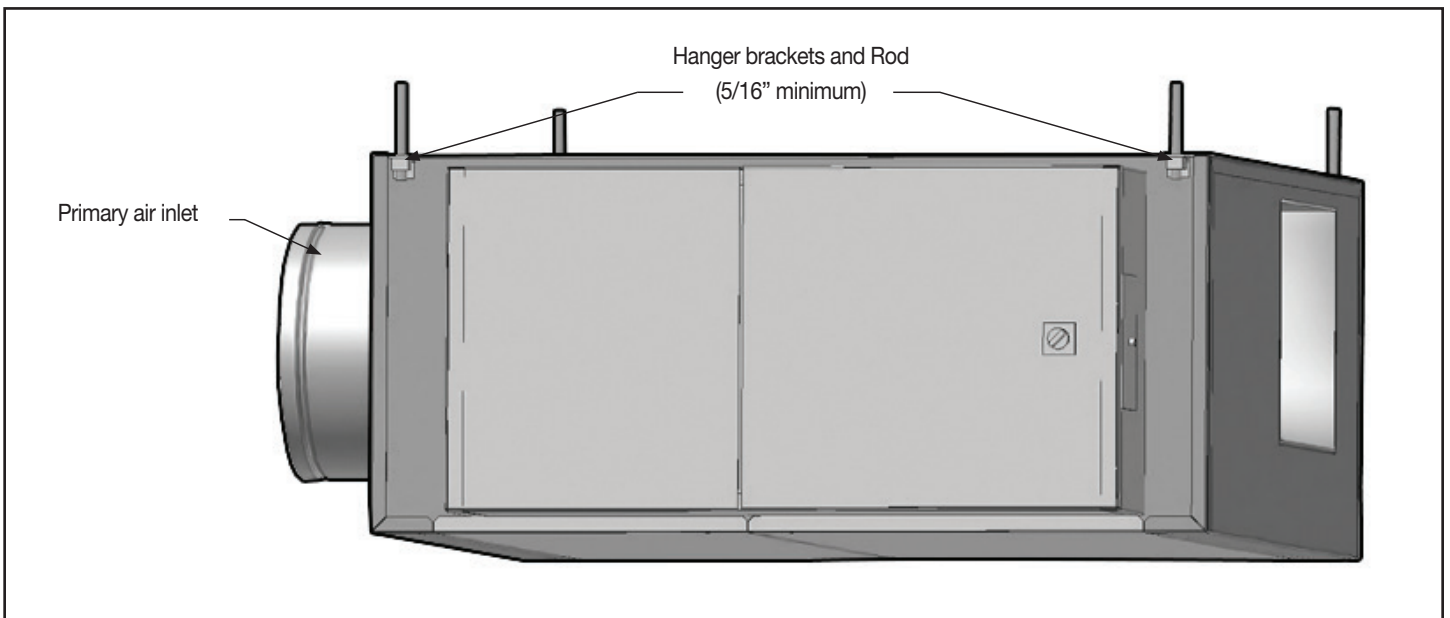

Figure 3 Optional Hanger Brackets and Hanger Rods



Important

If equipped with pneumatic controls, the orientation of the Air Terminal unit is critical. The pneumatic controls must be mounted right side up. The Single Duct Air Terminal must be level within + or - 10 degrees of horizontal, both parallel to the air flow and at right angle of air flow. The control side of the Air Terminal is labeled with an arrow indicating up. Unless otherwise noted, most electric, analog electronic and digital are not position sensitive and may be installed in any orientation.

Minimum Clearance for Access

Single Duct Air Terminals require sufficient space to allow servicing of the controls and electric reheat power hook up (if applicable). Horizontal clearance requirements are dependent upon access panel dimensions which are indicated on the appropriate submittal. For control panel access, a minimum of 18" is recommended. See the appropriate submittal for control panel location.

Note: These clearances recommendations are not meant to preclude NEC requirements or local building codes that may be applicable, which are the responsibility of the installing contractor.

Connecting Duct Work

1. Slip each inlet duct over the inlet collar of the Air Terminal.
2. Fasten and seal the connection by method prescribed by job specification.
3. The diameter of the inlet duct in inches, must be equal to the listed size of the Air Terminal; e.g. a duct that actually measures 8 inches must be fitted to a size 8 inch Air Terminal. The inlet tube of the Air Terminal is manufactured 1/8" smaller than the listed size in order to fit inside the duct.

Note: Do not insert duct work inside the inlet collar of the Air Terminal. Inlet duct should be installed in accordance with SMACNA guidelines.

4. If an inlet air flow sensor is installed, it is recommended the installer provide a minimum of 3 duct diameters of straight duct at the Air Terminal inlet.
5. The outlet end of the Air Terminal is designed for use with slip and drive duct connections (flanged outlets optional).
6. A rectangular duct the size of the Air Terminal outlet should be attached.

Field Electrical Wiring

- ☑ All field wiring must comply with local building codes and NEC. (ANSI/NFPA 70-2002)
- ☑ When Applicable, electrical control and piping diagrams are attached to bottom of Air Terminal.
- ☑ If an access door is provided on the bottom of the Air Terminal, the wiring or piping diagram is installed on the bottom of the control panel cover.
- ☑ Use copper only conductors.
- ☑ Air Terminal must be properly grounded per NEC 424-14 and 250.
- ☑ Always check product label for voltage and current data to determine the proper wire size and over current protection.
- ☑ The control cabinet contains live electrical parts.
- ☑ Contacting these parts with power applied may cause serious injury or even death.
- ☑ The control panel cover must be closed or in place before applying electric power to the Air Terminal.
- ☑ These recommendations are not meant to preclude NEC requirements or applicable local building codes and are the sole responsibility of the installing contractor.

Single Duct Air Terminals with Electric Reheat

Always inspect the electric heating coils for damage prior to installing the Fan Powered Air Terminal.

- Always inspect the electric heating coils for damage prior to installing the Single Duct Air Terminal.
- All electric reheat is balanced by kW per stage.
- The installing electrician should rotate these electric reheat stages by phase in order to balance the buildings electrical load.
- The "UP" arrow orientation must be followed to prevent nuisance tripping or over heating which will cause damage to the electric heater and or building.

Single Duct Air Terminals with Hot Water Coils

- Always inspect the hot water coils for damage prior to installing the Single Duct Air Terminal.



Caution: The copper tubing should not be used as lift points.

- The hot water coil casing must be field insulated.
- The hot water coils do not have drip pans and are not suitable for use as cooling coils.

Controls

For information on controls provided by other manufactures and installed on the Air Terminals, contact the local branch or dealer.

Important

Air Terminals with digital controls, if factory programmed, incorporate specific communication addresses. Installing the Air Terminal in a different location than noted on the Air Terminal label and building plans, may result in excessive start up labor and is the sole responsibility of the contractor.

Inlet Flow Sensor

Single Duct Air Terminals are shipped with factory installed (where applicable) pressure differential inlet flow sensors in the primary inlet. **See figure 4** for calibration curve and K factors. Bypass Air Terminals offer an optional downstream flow sensor for field installation a minimum of 3 feet downstream of box discharge.

Labeling

Single Duct Air Terminals are shipped from the factory with multiple information labels.

Control Sequence Label: Affixed to the terminal casing bottom. Displays piping/wiring diagram, control sequence number and any optional components.

Terminal I.D. Label: Affixed to bottom on cooling only and hot water reheat. If electric heat, affixed to control enclosure door. Shows tagging, representative name, sales order number, applicable certifications, model number, Made in USA, any applicable electrical data and UL compliance markings.

AHRI Certification Label: Identifies applicable industry test standard and certifies Air Terminal is in compliance.

AHRI Certification on Hot Water Coil (if applicable): Identifies applicable industry test standard and certifies hot water coil compliance.

Orientation Label: Identifies the proper air flow direction and top of Air Terminal.

Troubleshooting

Investigating Noise Complaints

- ☑ Noise from an Air Terminal can be due to a variety of conditions and can be difficult to eliminate.
- ☑ The first step is to isolate the type, source and direction.
- ☑ Generally, noise heard at the air outlet is considered a discharge type.
- ☑ Noise heard through the ceiling is considered radiated noise.
- ☑ For detailed information concerning noise transmission in buildings, refer to AHRI Standard 885-2008, "Procedure for estimating occupied space sound levels in the application of Air Terminals and air outlets".

Discharge Noise

- ☑ This is usually caused by high static or little to no internal duct lining downstream of the Air Terminal.
- ☑ It can sometimes be caused by air outlet itself.
- ☑ Air outlet generated sounds can be reduced by reducing flow or increasing an outlet size.
- ☑ Reducing static pressure, flow or adding additional downstream attenuation materials will reduce discharge sounds from the Air Terminal.

Radiated Noise

- ☑ Radiated noise is most commonly associated with Fan Powered Terminals.

Troubleshooting

Electric Duct Heater



Caution: Use extreme care if testing the electric heater with power on!

The control cabinet contains live electrical parts. Contacting these parts with the power applied may cause serious injury or death.



Caution: This unit should be serviced by a licensed electrician or a similarly qualified electrical service technician!

If the electric heater does not operate:

- ☑ Check electric power into the unit and verify the input power agrees with the label data.
- ☑ Verify the Air Terminal is installed properly (according to the air flow orientation).
- ☑ Review the wiring diagram attached to the inside of the control enclosure cover to verify the field wiring is correct with proper gauge wire, overcurrent protection and properly grounded.

If the electric heater cycles on and off:

- ☑ Verify the air flow is uniformly distributed across the face of the heater elements.
- ☑ Check for obstructions in the duct or insufficient air flow. (70 CFM per kW required)

If conditioned space fails to warm up:

- ☑ Verify the electric heater controls and thermostat are compatible and wired properly.
- ☑ Relocate the room thermostat if it is located in position that is too warm.

If condition space overheats:

- ☑ Verify the electric heater controls and room thermostat are compatible and wired properly.
- ☑ Relocate the room thermostat if it is located in position that is too cold.
- ☑ Verify the air distribution to the space is appropriate for the required thermal load.

Specific Electric Heater Troubleshooting Procedures:

Problem	Cause	Solution
Heater does not energize	Power not properly connected to the heater	<ol style="list-style-type: none"> 1. With a voltmeter, check the power wiring terminals to ensure proper voltage is available to the heater element side of the power terminal block or to the field side of the disconnect switch, power fusing or circuit breaker. 2. If proper voltage is not present, check the terminal studs for proper wiring and check power source for power.
	Disconnect switch, toggle switch or circuit breaker are set to OFF position	<ol style="list-style-type: none"> 1. Set disconnect switch, toggle switch or circuit breaker to ON position.
	Power fuses are blown or circuit breaker is tripped	<ol style="list-style-type: none"> 1. Replace fuse(s) with same type and amperage as those provided with the heater from the manufacturer or reset circuit breaker by first setting circuit breaker to OFF position then resetting to ON position. 2. With an ammeter, check amp draw on the power lines. 3. For heaters with fusing, amp draw should not exceed the fuse amperage. 4. Amp draw should not exceed the circuit breaker rated value. 5. If the amp draw is excessive, check the power supply as described above for power voltage. 6. If fuses blow or circuit breaker trips again, check for a short. 7. If no short is present and the power supply wiring/voltage are correct, contact factory for further assistance.
	Manual reset safety switch has tripped	<ol style="list-style-type: none"> 1. Push the reset safety button on back of safety reset. The manual safety reset is located inside the control enclosure cover near the bottom on the heater element header.
	Air flow/static switch is not engaging	<ol style="list-style-type: none"> 1. Jumper out the air flow/static switch by connecting the lead attached to the normally open terminal to the normally close terminal. 2. If the heater starts operating, two conditions could exist. <ol style="list-style-type: none"> A. The air flow/static switch may be defective. B. There is insufficient air flow to make the switch. 3. To verify available static pressure, disconnect the pneumatic tubing from the HI side of the air flow/static switch and connect to a magnehelic gauge. 4. Available static pressure should be 0.05 + or - 0.03" or 0.08" wc to be safe. 5. If available static pressure is in a dead band, between the two ranges, the air flow/static switch will not engage and could cause chattering of the contacts. Some method must be devised to increase the available static pressure. 6. If sufficient static pressure is available, check to ensure the pneumatic tubing is connected to the correct port (HI) on the air flow/static switch.
	Automatic Safety Reset Switch is bad	<ol style="list-style-type: none"> 1. Allow the duct temperature to cool down below 90° F. 2. If the heater still does not energize, jumper out the automatic safety reset switch. 3. If the heater now energizes, contact the factory for a replacement automatic safety reset switch.

Specific Electric Heater Troubleshooting Procedures (Cont.):

Problem	Cause	Solution
	Manual Safety Reset Switch is bad	<ol style="list-style-type: none"> 1. Allow the duct temperature to cool down below 90° F. 2. If the heater still does not energize, perform the following. 3. On heaters with the manual safety reset switch connected in the backup contact circuit, jumper out the manual safety reset switch. 4. If the backup contractor now engages, contact the factory for a replacement manual safety reset switch. 5. If the backup contractor fails to engage, there is a problem in the backup contractor holding coil. 6. Use an ohmmeter to check continuity of the holding coil on the backup contractor. 7. If bad, contact factory for replacement backup contractor.
	Insufficient air flow across the electric heating elements	<ol style="list-style-type: none"> 1. Then minimum allowable air flow across the heating elements is 70 CFM/kW. 2. Unless this recommended minimum air flow is met, the leaving air temperature of the heater will be greater than the safety reset switches limits. This will cause nuisance tripping of the safety reset switch. 3. Reset the minimum air flow across the heating elements during a call for heat at 70 CFM/kW.



Warning: On all troubleshooting that requires working inside the heater casing, disconnect the power first!
 Jumpers used for diagnostic purposes should be removed before returning the heater to normal operation.

Figure 4
MULTI-QUADRANT AVERAGING FLOW SENSOR

MODEL	INLET SIZE	K FACTOR
XG-TH, XG-FCL, XG-FCQ XG-FVI, XG-DD XG-DH, XG-BP XG-RT, XG-RA XG-TL (4 TO 10) XG-FCL C2 (4 TO 8) XG-FVL C2 (4 TO 8)	04 Rnd	300
	05 Rnd	375
	06 Rnd	540
	07 Rnd	760
	08 Rnd	990
	09 Rnd	1250
	10 Rnd	1640
	12 Rnd	2350
	14 Rnd	3250
	16 Rnd	4100
XG-TL (12)	12 Flat Oval	2270
XG-TL(14) & XG-FVL C6	14 Flat Oval	2850
XG-TL (16)	16 Flat Oval	3550
XG-FVL C4	14x8 Rect	2450
XG-FCL C4	16x8 Rect	2770
XG-FCI, XG-FCQ, & XG-FVI C7	18x16 Rect	6200
XG-TH 20	20x16 Rect	6430
XG-TH 24	24x16 Rect	7270

Note: K-factor is the calibration flow constant at 1" w.g. delta P

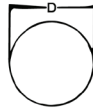
Rnd

SIZE	D (in.)
04 Rnd	4
05 Rnd	5
06 Rnd	6
07 Rnd	7
08 Rnd	8
09 Rnd	9
10 Rnd	10
12 Rnd	12
14 Rnd	14
16 Rnd	16

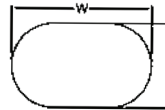
Flat Oval

SIZE	W (in.)	H (in.)
12 Flat Oval	13	10
14 Flat Oval	16.25	10
16 Flat Oval	16.25	10

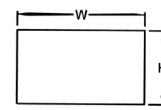
Rect

SIZE	W (in.)	H (in.)
14x8 Rect	14	10
16x8 Rect	16	10
20x16 Rect	20	10
24x16 Rect	24	16

$$Cfm = \sqrt{\Delta p} \times K \text{ Factor}$$

